

RIGOL

用户手册

RP7000 系列有源探头

2013 年 12 月

RIGOL Technologies, Inc.

保证和声明

版权

© 2011 北京普源精电科技有限公司版权所有。

商标信息

RIGOL 是北京普源精电科技有限公司的注册商标。

文档编号

UGE07007-1110

声明

- 本公司产品受已获准及尚在审批的中华人民共和国专利的保护。
- 本公司保留改变规格及价格的权利。
- 本手册提供的信息取代以往出版的所有资料。
- 对于本手册可能包含的错误，或因手册所提供的信息及演绎的功能，以及因使用本手册而导致的任何偶然或继发的损失，**RIGOL** 概不负责。
- 未经 **RIGOL** 事先书面许可不得影印复制或改编本手册的任何部分。

产品认证

RIGOL 认证本产品符合中国国家产品标准和行业产品标准及 ISO9001:2008 标准和 ISO14001:2004 标准，并进一步认证本产品符合其它国际标准组织成员的相关标准。

联系我们

如您在使用此产品或本手册的过程中有任何问题或需求，可与 **RIGOL** 联系：

电子邮箱：service@rigol.com

网址：www.rigol.com

安全术语和符号

本手册中的术语。以下术语可能出现在本手册中：



警告

警告性声明指出可能会危害操作人员生命安全的条件和行为。



注意

注意性声明指出可能导致本产品损坏或数据丢失的条件和行为。

产品上的术语。以下术语可能出现在产品上：

危险 表示您如果进行此操作可能会立即对您造成危害。

警告 表示您如果进行此操作可能会对您造成潜在的危害。

注意 表示您如果进行此操作可能会对本产品或连接到本产品的其他设备造成损坏。

产品上的符号。以下符号可能出现在产品上：



高电压



安全警告



保护性
接地端



壳体接地端



测量接地端

文档概述

本手册用于指导用户快速了解 RP7000 系列有源探头及其使用方法，并提供保养与清洁等服务信息。

RP7000 系列有源探头包含如下型号。

型号	带宽
PR7150	>1.5GHz
RP7080	>0.8GHz

主要内容包括：

- **RP7000 系列有源探头概述**
简介探头，包括：一般性检查、探头尺寸、标准附件等。
- **使用 RP7000 系列有源探头**
介绍如何使用探头，包括：连接示波器、探头前端的使用、更换探头配件、调节偏移电压、校准探头等。
- **保养与清洁**
- **保修概要**
- **性能指标**

目录

保证和声明	I
安全术语和符号	II
文档概述	III
RP7000 系列有源探头概述	1
探头简介	2
一般性检查	3
探头尺寸	4
附件和选件	5
有源探头放大器	7
探头前端	8
使用 RP7000 系列有源探头	11
连接示波器	12
探头前端的使用	14
更换探头配件	18
调节偏移电压	19
校准探头	20
保养与清洁	21
保修概要	22
性能指标	23

RP7000 系列有源探头概述

本部分指导用户快速了解 RP7000 系列有源探头。

主要包括：

- 探头简介
- 一般性检查
- 探头尺寸
- 附件和选件
- 有源探头放大器
- 探头前端

探头简介

RP7000是一款带宽高于1.5GHz，针对于高频解决方案的有源探头。它可以测量差分信号和单端信号，并具有较好的共模抑制效果。RP7000使用快插式探头前端，支持四种探头前端相互更换，从而优化了探头性能，提高了探头可用性。允许用户更换探头尖，延长探头的使用寿命。探头尖的间距可精细调节以适应不同的待测点间距。

RP7000与**RIGOL** DS6000/MSO4000/DS4000系列示波器的自动识别接口兼容，可由该接口自动识别和配置。其卡入式BNC连接器使得与示波器的连接更加方便。

RP7000提供丰富的附件和选件，并且诸多部件采用可替换的设计原则，可方便的应用于不同的测试测量解决方案。

一般性检查

1. 检查运输包装

如运输包装已损坏，请保留被损坏的包装或防震材料，直到货物经过完全检查且探头通过电性和机械测试。

因运输造成探头损坏，由发货方和承运方联系赔偿事宜。**RIGOL** 公司恕不进行免费维修或更换。

2. 检查探头

若存在机械损坏或缺失，或者探头未通过电性和机械测试，请联系您的 **RIGOL** 经销商。

3. 检查附件

请根据本手册**附件和选件**一节检查随机附件，如有损坏或缺失，请联系您的 **RIGOL** 经销商。

探头尺寸

图 1 给出了 RP7000 系列有源探头主体部分的尺寸示意图。



图 1 探头尺寸

附件和选件

本节列出了 RP7000 系列有源探头套件及其标准附件。所列部件均可通过 **RIGOL** 订购。RP7150 有源探头套件（订货号为 RP7150）包含表 1 所列全部标准附件。如需单独订购附件或选件，请参考表 1。RP7080 有源探头套件（订货号为 RP7080）包含表 2 所列全部标准附件。如需单独订购附件或选件，请参考表 2。

表 1 RP7150 有源探头套件（订货号为 RP7150）标准附件

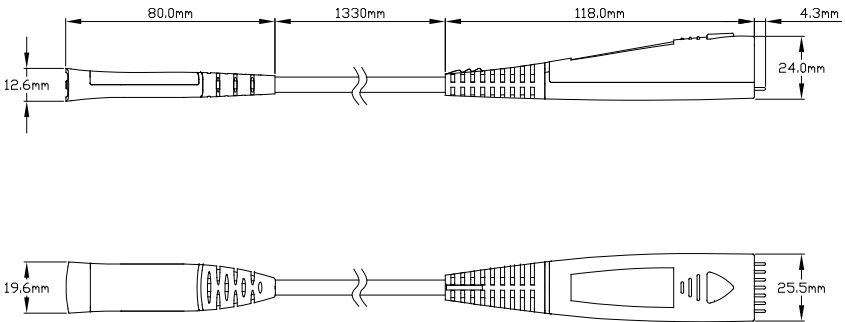
名称	订货号	数量
PCK100 有源差分探头校准套件	PCK100	1
RP7150 有源探头放大器	RP7-0150	1
焊接式差分探头前端	RP7-0201	1
焊接式单端探头前端	RP7-0203	1
手持式差分探头前端	RP7-0204	1
手持式单端探头前端	RP7-0205	1
0.2mm 镍丝	RP7-0306	1
修剪标尺	RP7-0307	1
91Ω 探头尖	RP7-0405	8
尖形直接地片	RP7-0501	2
尖形弯接地片	RP7-0502	2
齿形直接地片	RP7-0503	2
齿形弯接地片	RP7-0504	2
标识环（黄、粉、浅蓝、深蓝）	RP-0203	8
用户手册	RP7-0601	1
探头包	RP7-0602	1
储物盒	RP7-0603	1

表 2 RP7080 有源探头套件（订货号为 RP7080）标准附件

名称	订货号	数量
PCK100 有源差分探头校准套件	PCK100	1
RP7080 有源探头放大器	RP7-0080	1
焊接式差分探头前端	RP7-0201	1
焊接式单端探头前端	RP7-0203	1
手持式差分探头前端	RP7-0204	1
手持式单端探头前端	RP7-0205	1
0.2mm 镍丝	RP7-0306	1
修剪标尺	RP7-0307	1
91Ω 探头尖	RP7-0405	8
尖形直接地片	RP7-0501	2
尖形弯接地片	RP7-0502	2
齿形直接地片	RP7-0503	2
齿形弯接地片	RP7-0504	2
标识环（黄、粉、浅蓝、深蓝）	RP-0203	8
用户手册	RP7-0601	1
探头包	RP7-0602	1
储物盒	RP7-0603	1

注意：本部分所列附件仅供参考，请以产品实物为准。

有源探头放大器

有源探头放大器（图 2）作为有源探头的主体部件，具有大于 1.5GHz 的带宽，它一端可与 DS6000 系列示波器连接，另一端可灵活插入用户所需的探头前端。



图 2 有源探头放大器

有源探头放大器与**探头前端**通过插拔方式进行连接。使用单端探头时，在插拔的过程中，请注意二者的正负极性。极性接反可能造成有源探头性能下降甚至损坏探头。

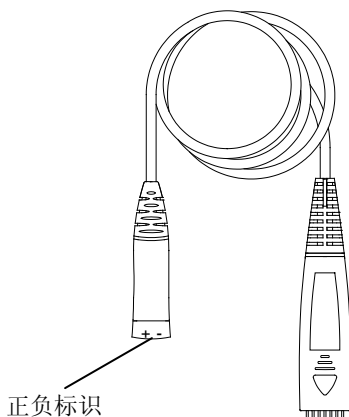

注意

手持式单端探头前端在连接处有正负标识；焊接式单端探头前端的负极带有黑色标识套。

探头前端

RP7000 支持**手持式探头前端**和**焊接式探头前端**。

1. 手持式探头前端

手持式探头前端包括两种类型：**手持式差分探头前端**和**手持式单端探头前端**。

使用此类探头前端，如同使用普通无源探头，您可以方便的测量信号。此外，探头尖间距可方便的调节以满足您不同的测量需求。

对于手持式差分探头前端，探头尖的间距由探头前端上的滚轮控制。前后拨动该滚轮便可精确调节两个探头尖的间距，如图 3 所示。



图 3 手持式差分探头前端

对于手持式单端探头前端，旋转单端接地片以改变接地片与探头尖的间距，如图 4 所示。

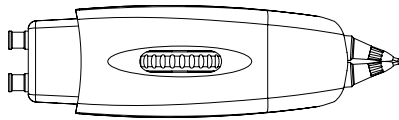

图 4 手持式单端探头前端

其中，探头尖与单端接地片是标准附件，如图 5 和图 6 所示。这两种部件均为可替换部件，如果在使用过程中被损坏，您可以方便地更换新的探头尖或单端接地片，更换方法请参考**更换探头配件**。

RP7000 提供四种单端接地片以适应不同的测量要求,各接地片的结构如图 6 所示。

- a) 尖形直接地片: 适用于近距离测试点的测量。
- b) 尖形弯接地片: 适用于较远距离测试点的测量。
- c) 齿形直接地片: 适用于近距离芯片管脚测试点的测量。
- d) 齿形弯接地片: 适用于较远距离芯片管脚测试点的测量。

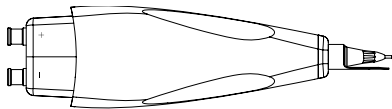

图 5 探头尖



图 6 (a) 尖形直接地片



图 6 (b) 尖形弯接地片



图 6 (c) 齿形直接地片

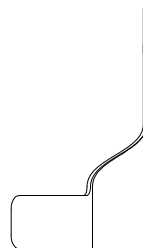

图 6 (d) 齿形弯接地片

2. 焊接式探头前端

焊接式探头前端也包括两种类型：**焊接式差分探头前端**和**焊接式单端探头前端**，见**图 7**和**图 8**。其中，焊接式差分探头前端适合测量高密度 IC 管脚的信号。

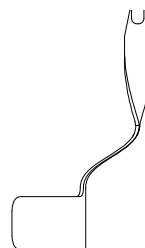

图 7 焊接式差分探头前端



图 8 焊接式单端探头前端

使用此类探头前端进行测量时，请注意使用辅助装置固定探头前端。注意，请勿使用手固定探头前端，否则容易造成探头前端焊接引线电阻线的断裂或脱落，且手握的位置也可能影响探头的性能。

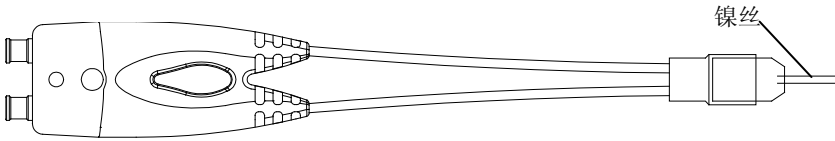
其中，焊接式探头前端的镍丝是标准附件，若在使用过程中被损坏，您可以参考**更换探头配件**一节进行更换。

使用 RP7000 系列有源探头

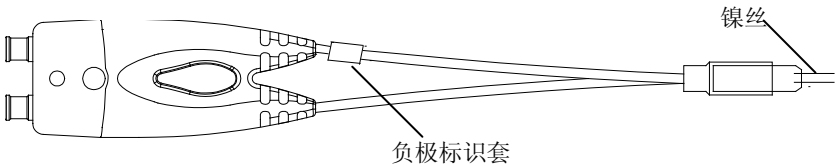
在使用 RP7000 系列有源探头的过程中，正确的使用方法可以保证探头性能，延长探头的使用寿命并保证信号测量结果的有效性。本部分将详细介绍 RP7000 系列有源探头的使用方法。

主要包括：

- 连接示波器
- 探头前端的使用
- 更换探头配件
- 调节偏移电压
- 校准探头

连接示波器

RP7000 系列有源探头与 RIGOL DS6000 系列示波器正确连接后，示波器自动识别探头并通过前面板为探头提供电源和偏移电压。此时，您可以通过示波器前面板菜单调节偏移电压（参考**调节偏移电压**一节）和校准探头（参考**校准探头**一节）等操作。

请按照如下步骤连接探头与示波器：

1. 将探头前端（图中以手持式差分探头前端为例）与有源探头放大器连接。注意，如果连接单端前端时，请注意正负极性。

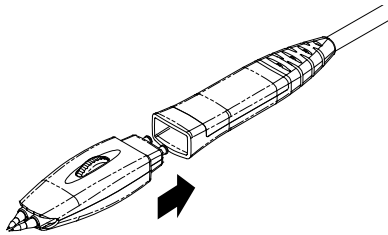

2. 将有源探头放大器的另一端连接到示波器通道输入或外部触发输入连接器，并推到紧闭的位置。

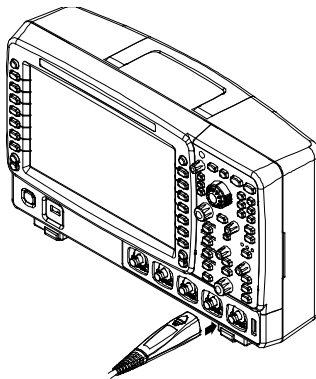

3. 使用任意探头辅助装置将其连接到待测电路中。

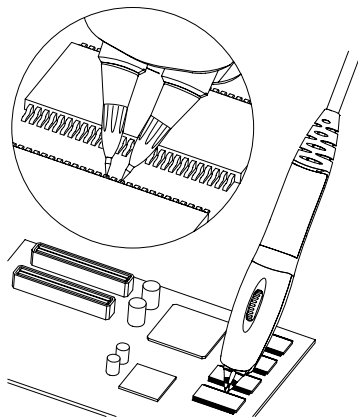

4. 需断开探头和示波器的连接时，首先按住探头上的按钮（见左下图），将连接器从示波器拔出后（见右下图），松开按钮即可。

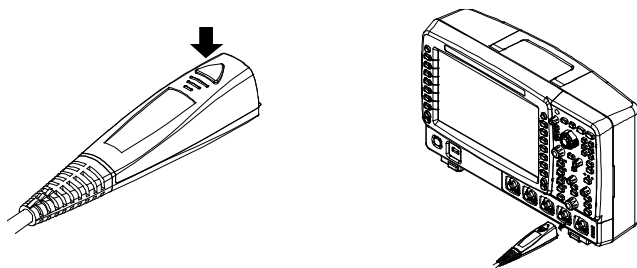

注意

不要试图从示波器 BNC 连接器上扭动探头，否则，可能导致探头损坏。

探头前端的使用

由**探头前端**一节可知，RP7000 系列可连接 4 种不同类型的探头前端。您可以参考**更换探头配件**一节所述方法更换探头前端。本节分别介绍 4 种类型探头前端的使用方法。

1. 手持式差分探头前端

手持式差分探头前端的有效带宽大于 1.5GHz，两路探头尖的间距可以通过拨动滚轮进行精细调节，探头尖允许更换，从而延长探头的使用寿命。

使用手持式差分探头前端，您可以方便的测量差分信号和单端信号。在进行信号测量时，您可以通过转动中间滚轮调整探头尖的间距以适应不同间距的测量。

手持式差分探头前端结构如图 9 所示。



图 9 手持式差分探头前端

- ① 拨动滚轮调节两个探头尖的间距（0mm 至 5.5mm）。
- ② 手持式差分探头前端（RP7-0204）。
- ③ 91Ω 探头尖（RP7-0405）。

2. 手持式单端探头前端

手持式单端探头前端的有效带宽大于 1.5GHz，探头尖与单端接地片的间距可以通过拨动单端接地片进行调节，探头尖和单端接地片允许更换，从而延长探头的使用寿命。

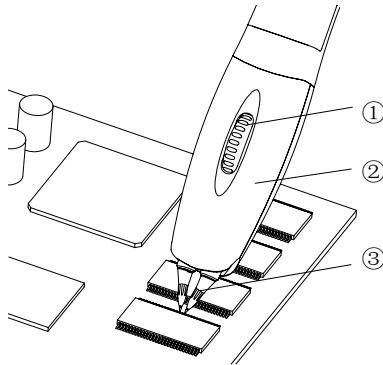
使用手持式单端探头前端，您可以方便的测量单端信号。在进行信号测量时，单端接地片需要接地。探头前端与有源探头放大器连接时，注意二者连接处的正负标识。

手持式单端探头前端结构如图 10 所示。



图 10 手持式单端探头前端

- ① 手持式单端探头前 (RP7-0205)。
- ② 91 Ω 探头尖 (RP7-0405)。
- ③ 尖形直接地片：转动接地片调节接地片与探头尖的间距 (0mm 至 5mm) (RP7-0501)。

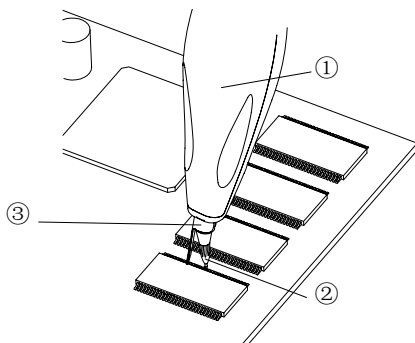

注意

使用手持式单端探头时，请将接地片就近接地。

3. 焊接式差分探头前端

焊接式差分探头前端的有效带宽大于 1.5GHz，允许用户更换镍丝，从而提高了探头的易用性，并延长了探头的使用寿命。

焊接式差分探头前端结构如图 11 所示。



图 11 焊接式差分探头前端

- ① 焊接式差分探头前端（RP7-0201）。
- ② 0.2mm 镍丝（RP7-0306）。

当待测点间距较远时，镍丝长度加长，会导致测试信号产生过冲和振铃，高频响应发生变化。

4. 焊接式单端探头前端

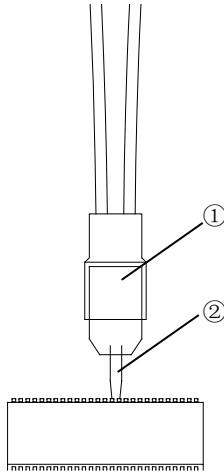
焊接式单端探头前端的有效带宽大于 1.5GHz，允许用户更换镍丝，从而提高了探头的易用性，并延长了探头的使用寿命。

焊接式单端探头前端结构如图 12 所示。位于负极标识套（见“图 8”）同一侧的引脚为负极。



图 12 焊接式单端探头前端

- ① 焊接式单端探头前端（RP7-0203）。
- ② 0.2mm 镍丝（RP7-0306）。

当待测点距离较远时，镍丝长度加长，会导致测试信号产生过冲和振铃，高频响应发生变化。

更换探头配件

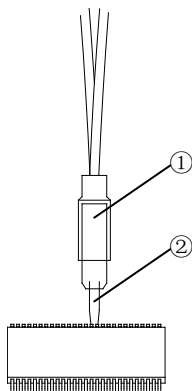
1. 更换探头前端

更换过程中请小心操作，以免破坏连接部分而影响探头的性能。

更换方法：

- ① 断开探头前端与有源探头放大器的连接。
- ② 将新的探头前端垂直插入有源探头放大器。连接单端探头前端时，请注意正负极性。

2. 更换探头尖

探头尖与探头前端以螺纹的方式进行连接，拆卸和安装探头尖时请注意旋转的方向和力度。

3. 更换单端接地片

更换单端接地片时，请确保接地片与铜管紧密连接，以保证探头的性能。

4. 更换镍丝

使用过程中，如果焊接式探头前端镍丝损坏或脱落，您可以更换新的镍丝。镍丝需要满足如下尺寸要求，即长度需小于 5mm。

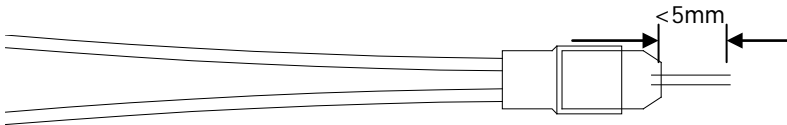

注意：当镍丝长度大于 5mm 时，会影响探头带宽指标。镍丝长度可以使用修剪标尺（PP7-0307）进行裁剪和测量。

调节偏移电压

RIGOL DS6000/MSO4000/DS4000 系列示波器系统为 RP7000 系列有源探头提供偏移电压。此偏移电压用于将超出有源探头放大器输入动态范围的被测信号调整至适当的范围，以保证被测信号的完整性。

此偏移电压可通过示波器前面板菜单进行调节。调整方法如下：

1. 按照**连接示波器**一节所述方法，将 RP7000 系列有源探头连接至 DS6000/MSO4000/DS4000 系列示波器的通道输入端（比如：CH1）。
2. 打开 DS6000/MSO4000/DS4000 示波器的探头偏移电压控制菜单（前面板操作：**CH1** → **探头** → **偏置电压**），使用旋钮调节偏移电压值。

校准探头

在使用 RP7000 系列有源探头前，您可以使用 PCK100 有源差分探头校准套件对探头进行校准。使用该套件校准 RP7000 有源探头的步骤如下：

1. 使用 1 个连接器分别连接校准板和连接线的 BNC(母头),然后将另一个连接器连接至校准板的另一端(称作部件 1)。
2. 连接 RP7000 有源探头至示波器的模拟通道(CH1-CH4, 本文以 CH1 为例进行说明)。
3. 打开示波器的探头校准控制菜单前面板操作：**CH1** → **探头** → **探头校准**，此时示波器的用户界面会弹出校准提示信息，请按照提示信息将部件 1 连接至示波器，通常情况下，将连接器的 BNC(公头)连接至相应的模拟通道，将连接线的 BNC(公头)连接至后面板**[Trig Out/Calibration]**端口。
4. 调节探头尖的间距，将正极探针连接至校准板的中间信号线上，将负极探针连接至信号线的两侧。注意：此处探头尖最好连接至校准板的中心附近。
5. 按 **开始** 软键，示波器开始对探头进行校准，探头校准的时间大约 40~50 秒，探头校准完成时示波器会根据校准结果弹出“探头校准完成”或“探头校准失败”提示信息。注意：以免影响校准精度，在校准过程中，探针尖必须始终与校准板紧密相连。

注意：RP7000 系列有源探头相关的性能指标依赖于探头的校准。完成校准后，有源探头的直流增益、偏移电压零点和偏移增益均被校准。用户可以通过菜单 **CH1** → **探头** → **探头信息**，查看探头的厂商、型号、序列号和上次校准时间等信息。

保养与清洁

保养:

请勿将探头及其附件放置在长时间受到日照的地方。



注意

请勿使任何腐蚀性的液体沾到探头及其附件上。

清洁:

请根据使用情况经常对探头及其附件进行清洁。方法如下:

1. 断开探头与示波器或电压源的连接。
2. 用潮湿但不滴水的软布（可使用柔和的清洁剂或清水）擦拭探头及其附件外部的浮尘。



警告

在重新使用前，请确认探头已经干透，避免因水分造成电气短路甚至人身伤害。

保修概要

北京普源精电科技有限公司及其授权生产的苏州普源精电科技有限公司（**RIGOL Technologies, Inc.**）承诺其生产仪器的主机和附件，在产品保修期内无任何材料和工艺缺陷。

在保修期内，若产品被证明有缺陷，**RIGOL** 将为用户免费维修或更换。详细保修条例请参见 **RIGOL** 官方网站或产品保修卡的说明。欲获得维修服务或保修说明全文，请与 **RIGOL** 维修中心或各地办事处联系。

除本概要或其他适用的保修卡所提供的保证以外，**RIGOL** 公司不提供其他任何明示或暗示的保证，包括但不限于对产品可交易性和特殊用途适用性之任何暗示保证。在任何情况下，**RIGOL** 公司对间接的，特殊的或继起的损失不承担任何责任。

性能指标

技术指标

指标名称	RP7150	RP7080
带宽	>1.5GHz	>0.8GHz
上升时间	<265ps	<465ps
系统带宽	1GHz (DS6104 或 DS6102)	0.8GHz (DS6104 或 DS6102)
输入电容	<1pF	
输入电阻	50k Ω \pm 2% 差分模式 25k Ω \pm 4% 单端模式	
输入动态范围	\pm 6.25V	
输入共模范围	\pm 6.75V DC~100Hz \pm 1.25V >100Hz	
共模抑制比	>45dB@1MHz	
直流衰减精度	10:1 \pm 2%	
零点偏移误差 ^[1]	<30mV 校准前 <5mV 校准后	
偏移电压范围	\pm 12V	
偏移精度 ^[1]	<3%当前量程 校准前 <1%当前量程 校准后	
输入噪声	45mVpp	
传输延迟	7ns	
最大输入电压	30V Peak CAT I ^[2]	
静电防护	>8kV	

一般规格

环境条件	操作环境	存放环境
温度	+5°C ~+40°C	-40°C ~+70°C
湿度	0 RH~80% RH	0 RH-90% RH
海拔	4600m	15300m
功耗	1.2W	N/A
重量	147±10g ^[3]	530±50g ^[4]
线长	1.4m	

[1] 典型值，其技术指标会随着示波器的档位不同而改变。

[2] CAT I 和 CAT II 的定义

装置种类（超压种类）I：信号电平，特殊设备或部分设备，无线电通讯和电子等，相对装置种类（超压种类）II 有更小的瞬态电压。

装置种类（超压种类）II：局部电平，器具，可携带设备等，相对装置种类（超压种类）III 有更小的瞬态电压。

[3] RP7000 配备手持式差分前端时的重量。

[4] RP7000 有源探头套件（含包装）的重量。

RIGOL

User's Guide

RP7000 Series Active Probe

Dec. 2013

RIGOL Technologies, Inc.

Guaranty and Declaration

Copyright

© 2011 RIGOL Technologies, Inc. All Rights Reserved.

Trademark Information

RIGOL is a registered trademark of RIGOL Technologies, Inc.

Publication Number

UGE07107-1110

Notices

- **RIGOL** products are protected by patent law in and outside of P.R.C.
- **RIGOL** reserves the right to modify or change parts of or all the specifications and pricing policies at company's sole decision.
- Information in this publication replaces all previously corresponding materials.
- **RIGOL** shall not be liable for losses caused by either incidental or consequential in connection with the furnishing, use or performance of this manual as well as any information contained.
- Any part of this document is forbidden to be copied or photocopied or rearranged without prior written approval of **RIGOL**.

Product Certification

RIGOL guarantees this product conforms to the national and industrial standards in China as well as the ISO9001:2008 standard and the ISO14001:2004 standard. Other international standard conformance certification is in progress.

Contact Us

If you have any problem or requirement when using our products or this manual, please contact RIGOL Technologies, Inc.

E-mail: service@rigol.com

Website: www.rigol.com

Safety Terms and Symbols

Terms in this Manual. The following terms may appear in this manual:



WARNING

Warning statements indicate the conditions or practices that could result in injuries or loss of life.



CAUTION

Caution statements indicate the conditions or practices that could result in damage to this product or loss of data.

Terms on the Product. The following terms may appear on the product:

DANGER indicates a hazard may immediately happen.

WARNING indicates potential hazard may happen.

CAUTION indicates damage to the instrument or other devices connected to the instrument may happen.

Symbols on the Product. The following symbols may appear on the product:



High Voltage



Safety Warning



Protective Earth terminal



Chassis Ground



Test Ground

Document Overview

This document is used to guide users to get a quick understanding of the RP7000 series active probe as well as its using method. Besides, this document gives service information relating to general care and cleaning.

RP7000 series active probe includes the following model.

Model	Bandwidth
PR7150	>1.5GHz
RP7080	>0.8GHz

Main topics:

- **RP7000 Series Overview**

This chapter gives a brief introduction of the probe, including general inspection, probe dimensions, standard accessories etc.

- **To Use RP7000 Series Active Probe**

This chapter introduces how to use the probe, including how to connect to the oscilloscope, how to use the probe head, how to replace probe accessories, how to adjust the offset voltage, how to calibrate the probe etc.

- **General Care and Cleaning**

- **Warranty**

- **Specifications**

Contents

- Guaranty and Declaration I**
- Safety Terms and Symbols II**
- Document Overview III**
- RP7000 Series Overview 1**
 - Probe Introduction 2
 - General Inspection 3
 - Probe Dimensions 4
 - Accessories and Options 5
 - Active Probe Amplifier 7
 - Probe Head 8
- To Use RP7000 Series Active Probe 12**
 - To Connect to the Oscilloscope 13
 - To Use the Probe Head 15
 - To Replace Probe Accessories 19
 - To Adjust Offset Voltage 21
 - To Calibrate the Probe 22
- General Care and Cleaning 24**
- Warranty 25**
- Specifications 26**

RP7000 Series Overview

This chapter guides users to quickly get familiar with the RP7000 series active probe.

Main topics:

- Probe Introduction
- General Inspection
- Probe Dimensions
- Accessories and Options
- Active Probe Amplifier
- Probe Head

Probe Introduction

RP7000, with more than 1.5GHz bandwidth, is an active probe solution for high frequency application. It can be used to measure differential and single-ended signals with better common mode rejection. RP7000 uses plug-on socket probe head and supports 4 types of interchangeable probe heads to optimize the performance and usability. Besides, its replaceable probe tip prolongs the service life of the probe and the probe tip spacing can be precisely adjusted to fit different test point spacing.

RP7000 is compatible with the auto-identification port of **RIGOL** DS6000/MSO4000/DS4000 series oscilloscope and can be recognized and configured automatically by this port. Its snap-in BNC connector enables easier connection with the oscilloscope.

RP7000 provides various accessories and options and multiple replaceable components which make it applicable to be used in different tests and measurements.

General Inspection

1. **Inspect the shipping container for damage.**

If your shipping container appears to be damaged, keep the shipping container or cushioning material until you have inspected the contents of the shipment for completeness and have checked the probe electrically and mechanically.

If your probe has damaged during shipping, please contact your shipper and carrier for compensation. **RIGOL** will provide no free repair or replacement.

2. **Inspect the probe.**

If there is any mechanical damage or defect, or if the probe does not pass electrical and mechanical tests, please contact your **RIGOL** sales representative.

3. **Check the Accessories.**

Please check the accessories according to **Accessories and Options** in this guide. If the accessories are incomplete or damaged, please contact your **RIGOL** sales representative.

Probe Dimensions

Figure 1 shows the dimensions of the main parts of RP7000 series active probe.

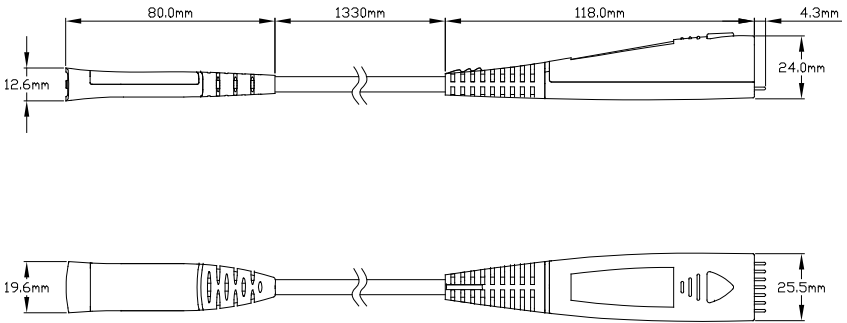

Figure 1 Probe Dimensions

Accessories and Options

This section lists the probe kits, standard accessories of the RP7000 series active probe respectively. All the components listed below can be ordered from **RIGOL**. RP7150 Active Probe Kit (the ordering number is RP7150) contains all the accessories listed in **Table 1**. If any accessory or option needs to be ordered separately, please refer to **Table 1**. RP7080 Active Probe Kit (the ordering number is RP7080) contains all the accessories listed in **Table 2**. If any accessory or option needs to be ordered separately, please refer to **Table 2**.

Table 1 RP7150 Active Probe Kit (Ordering NO. is RP7150) Standard Accessories

Name	Ordering NO.	Qty.
PCK100 Active Differential Probe Calibration Kit	PCK100	1
RP7150 Active Probe Amplifier	RP7-0150	1
Solder-in Differential Probe Head	RP7-0201	1
Solder-in Single-ended Probe Head	RP7-0203	1
Hand-held Differential Probe Head	RP7-0204	1
Hand-held Single-ended Probe Head	RP7-0205	1
0.2mm Nickel Wire	RP7-0306	1
Trim Gauge	RP7-0307	1
91Ω Probe Tip	RP7-0405	8
Straight Acuminate Ground Collar	RP7-0501	2
Curved Acuminate Ground Collar	RP7-0502	2
Straight Dentiform Ground Collar	RP7-0503	2
Curved Dentiform Ground Collar	RP7-0504	2
Marker Rings (Yellow/Pink/Light Blue/Dark Blue)	RP-0203	8
User's Guide	RP7-0601	1
Probe Bag	RP7-0602	1
Storage Box	RP7-0603	1

Table 2 RP7080 Active Probe Kit (Ordering NO. is RP7080) Standard Accessories

Name	Ordering NO.	Qty.
PCK100 Active Differential Probe Calibration Kit	PCK100	1
RP7080 Active Probe Amplifier	RP7-0080	1
Solder-in Differential Probe Head	RP7-0201	1
Solder-in Single-ended Probe Head	RP7-0203	1
Hand-held Differential Probe Head	RP7-0204	1
Hand-held Single-ended Probe Head	RP7-0205	1
0.2mm Nickel Wire	RP7-0306	1
Trim Gauge	RP7-0307	1
91Ω Probe Tip	RP7-0405	8
Straight Acuminate Ground Collar	RP7-0501	2
Curved Acuminate Ground Collar	RP7-0502	2
Straight Dentiform Ground Collar	RP7-0503	2
Curved Dentiform Ground Collar	RP7-0504	2
Marker Rings (Yellow/Pink/Light Blue/Dark Blue)	RP-0203	8
User's Guide	RP7-0601	1
Probe Bag	RP7-0602	1
Storage Box	RP7-0603	1

Note: the accessories listed in this section are only for reference, the actual product is the standard.

Active Probe Amplifier

The active probe amplifier (**Figure 2**), with more than 1.5GHz bandwidth, is a main component of the active probe. One end of the active probe amplifier can be connected to the DS6000 series oscilloscope and the other end can be connected to the desired probe head.

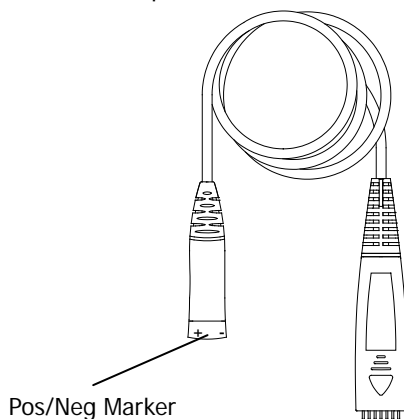

Figure 2 Active Probe Amplifier

When connecting a **probe head** to an **active probe amplifier**, push it straight in. For single-ended probe, when connecting them, pay attention to their polarities. If the polarity is reversed, the performance of the active probe would reduce and the active probe might even be damaged.



CAUTION

There are Pos/Neg markers on the hand-held single-ended probe head and black mark sleeve on the negative pole of the solder-in single-ended probe head.

Probe Head

RP7000 supports **hand-held probe head** and **solder-in probe head**.

1. Hand-held Probe Head

Hand-held probe head includes two types: **hand-held differential probe head** and **hand-held single-ended probe head**.

Like using common passive probes, you can use this kind of probe head to easily measure signals. Besides, the spacing between the probe tips can be easily adjusted to fulfill your various measurement requirements.

For hand-held differential probe head, the spacing between the probe tips is controlled by the roller on the probe head. As shown in **Figure 3**, turning the roller forwards or backwards can precisely adjust the spacing between the two probe tips.

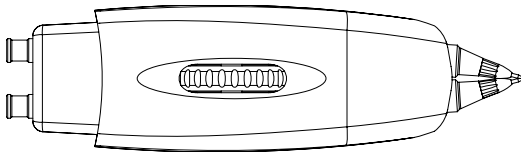

Figure 3 Hand-held Differential Probe Head

For hand-held single-ended probe head, rotating the single-ended ground collar adjusts the spacing between the single-ended ground collar and probe tip, as shown in **Figure 4**.

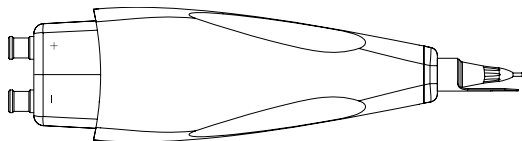

Figure 4 Hand-held Single-ended Probe Head

Wherein, as shown in **Figure 5** and **Figure 6**, probe tip and single-ended ground collar are standard accessories and are both replaceable. If any of them is damaged during use, you can easily replace it with a new one (refer to **To Replace Probe Accessories**).

RP7000 provides 4 kinds of single-ended ground collars for different measurement requirements, the structures of the ground collars are as shown in **Figure 6**.

- a) Straight Acuminate Ground Collar: applicable to measurement of test point that is close to the ground point.
- b) Curved Acuminate Ground Collar: applicable to measurement of test point that is relatively far from the ground point.
- c) Straight Dentiform Ground Collar: applicable to measurement of chip pin test point that is close to the ground point.
- d) Curved Dentiform Ground Collar: applicable to measurement of chip pin test point that is relatively far from the ground point.

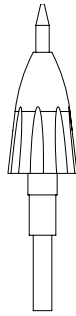

Figure 5 Probe Tip



Figure 6 (a)

Straight Acuminate Ground Collar

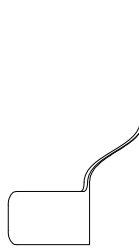

Figure 6 (b)

Curved Acuminate Ground Collar



Figure 6 (c)

Straight Dentiform Ground Collar

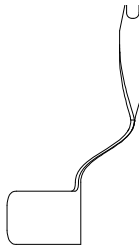

Figure 6 (d)

Curved Dentiform Ground Collar

2. Solder-in Probe Head

Solder-in probe head includes two types: **solder-in differential probe head** and **solder-in single-ended probe head** as shown in **Figure 7** and **Figure 8**. Wherein, solder-in differential probe head is suitable for measurement of high-density IC pin signals.

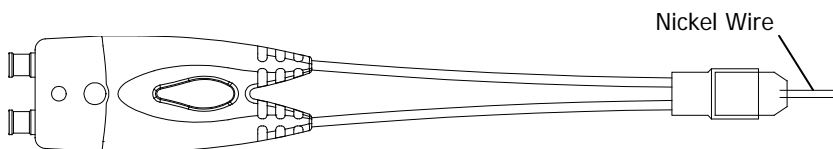

Figure 7 Solder-in Differential Probe Head

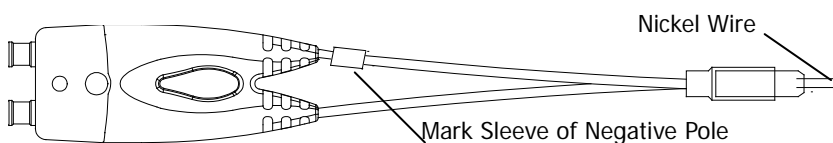

Figure 8 Solder-in Single-ended Probe Head

When using the solder-in probe head for measurement, please use auxiliary device to fix the probe head. Do not use your hand to fix the probe head, or else, the lead resistor soldered onto the probe head might break or fall off, what's more, the hand-held position might also affect the probe performance.

Wherein, the nickel wire of the solder-in probe head is a standard accessory. If the nickel wire under use became damaged or break off, please replace it with an appropriate lead resistor (refer to **To Replace Probe Accessories**).

To Use RP7000 Series Active Probe

During the use of RP7000 series active probe, correct operations can ensure the probe performance, prolong the service life of the probe and ensure the effectiveness of the signal measurement result. This chapter introduces in detail the using method of the RP7000 series active probe.

Main Topics:

- To Connect to the Oscilloscope
- To Use the Probe Head
- To Replace Probe Accessories
- To Adjust Offset Voltage
- To Calibrate the Probe

To Connect to the Oscilloscope

After RP7000 is connected correctly to a **RIGOL** DS6000 series oscilloscope, the oscilloscope recognizes the probe automatically and provides both power and offset voltage to the probe. You can adjust the offset voltage (refer to **To Adjust Offset Voltage**) and calibrate the probe (refer to **To Calibrate the Probe**) by the front panel menu of the oscilloscope.

Please connect the probe to the oscilloscope following the steps below:

1. Connect the probe head (in the figure, taking a hand-held differential probe head for example) with the active probe amplifier. If single-ended probe head is used, during the connection, pay attention to their polarities.

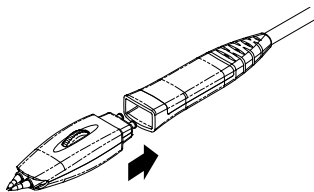

2. Connect the other end of the active probe amplifier to the channel input or external trigger input connector of the oscilloscope and make sure the connection is tight.

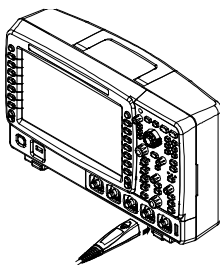

3. Use any probe auxiliary device to connect the probe to the circuit to be

tested.

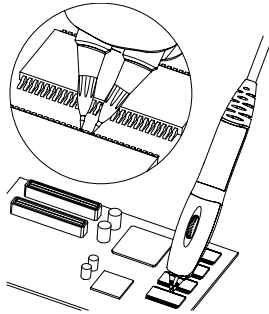

4. To disconnect the probe from the oscilloscope, press the button on the probe (as shown in the left figure below), pull the connector straight out of the oscilloscope (as shown in the right figure below) and then release the button.

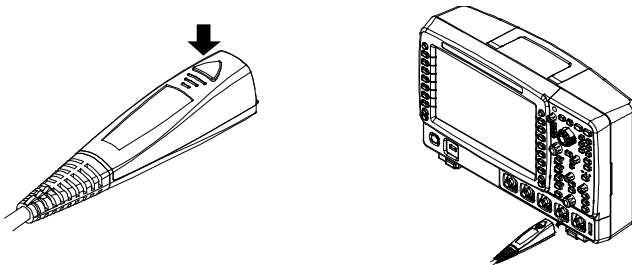

CAUTION

Do not twist the probe on the BNC connector of the oscilloscope, or else, the probe might be damaged.

To Use the Probe Head

Known from **Probe Head**, RP7000 can be connected with 4 kinds of probe heads. You can easily change the probe head by using the method introduced in **To Replace Probe Accessories**. This chapter introduces how to use the four kinds of probe heads respectively.

1. Hand-held Differential Probe Head

The hand-held differential probe head provides an effective bandwidth of more than 1.5GHz. Besides, the spacing between the two probe tips can be precisely adjusted by turning the roller and the replaceable probe tips prolong the service life of the probe.

The hand-held differential probe head can be used to measure differential and single-ended signals. During the measurement, you can turn the roller on the probe head to adjust the spacing between the probe tips so as to fit measurements with different spacing requirements.

The structure of the hand-held differential probe head is as shown in **Figure 9**.

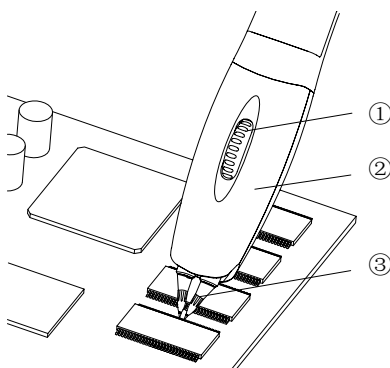

Figure 9 Hand-held Differential Probe Head

- ① Turning the roller to adjust the spacing (0mm to 5.5mm) between the two probe tips.
- ② Hand-held differential probe head (RP7-0204).
- ③ 91Ω probe tip (RP7-0405).

2. Hand-held Single-ended Probe Head

The hand-held single-ended probe head provides an effective bandwidth of more than 1.5GHz. Besides, the spacing between the single-ended ground collar and probe tip can be adjusted by rotating the ground collar and the replaceable probe tip and single-ended ground collar prolong the service life of the probe.

The hand-held single-ended probe head can be used to measure single-ended signal. During the measurement, the single-ended ground collar must be grounded. Pay attention to their polarities when connecting the probe head and active probe amplifier.

The structure of the hand-held single-ended probe head is as shown in **Figure 10**.

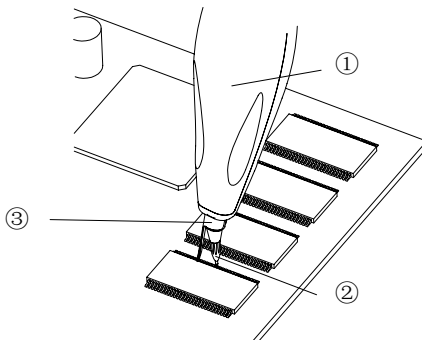

Figure 10 Hand-held Single-ended Probe Head

- ① Hand-held single-ended probe head (RP7-0205).
- ② 91 Ω probe tip (RP7-0405).
- ③ Straight acuminate ground collar: rotating the ground collar adjusts the spacing (0mm to 5mm) between the ground collar and probe tip (RP7-0501).

**CAUTION**

Ground the ground collar when using the hand-held single-ended probe.

3. Solder-in Differential Probe Head

The solder-in differential probe head provides an effective bandwidth of more than 1.5GHz and its replaceable nickel wire enhance the usability of the probe and prolong its service life.

The structure of the solder-in differential probe head is as shown in **Figure 11**.

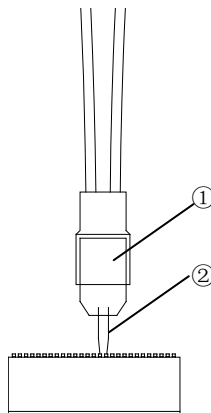

Figure 11 Solder-in Differential Probe Head

- ① Solder-in differential probe head (RP7-0201).
- ② 0.2mm Nickel Wire (RP7-0306).

When the points to be tested are widely spaced, the length of the nickel wire will be increased. At this point, overshoot and ringing will occurs and the high-frequency response will changes.

4. Solder-in Single-ended Probe Head

The solder-in single-ended probe head provides an effective bandwidth of more than 1.5GHz and its replaceable nickel wire enhance the usability of the probe and prolong its service life.

The structure of the solder-in single-ended probe head is as shown in **Figure 12**.

The pin on the same side with the negative pole mark sleeve (refer to **Figure 8**) is negative.

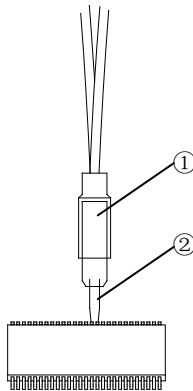

Figure 12 Solder-in Single-ended Probe Head

-
- ① Solder-in single-ended probe head (RP7-0203).
 - ② 0.2mm Nickel Wire (RP7-0306).

When the points to be tested are widely spaced, the length of the nickel wire will be increased. At this point, overshoot and ringing will occurs and the high-frequency response will changes.

To Replace Probe Accessories

1. To replace the probe head

Take care not to damage the connecting part to avoid affecting the probe performance when replacing the probe head.

Replacing Method:

- ① Disconnect the current probe head from the active probe amplifier.
- ② Push the new probe head into the active probe amplifier straightly.
When single-ended probe head is used, pay attention to their polarities.

2. Replace the probe tip

The probe tip and probe head are connected with screw thread, so please note the screw rotation and strength when removing and installing the probe tip.

3. Replace the single-ended ground collar

Make sure the single-ended ground collar is firmly connected to the copper pipe to ensure the probe performance when replacing it.

4. To replace the nickel wire

If the nickel wire of the solder-in probe head under use become damaged or break off, you can replace a new one. The probe head nickel wire should satisfy the following size requirement, namely the length must be shorter than 5mm.

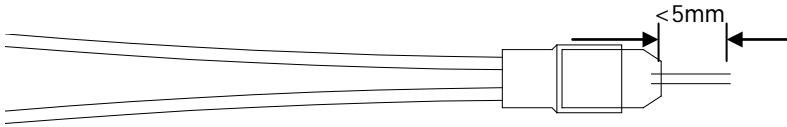

Note: If the length of the nickel wire is longer than 5mm, the bandwidth specification of the probe will be effected. You can use the trim gauge (RP7-0307) to measure and cut the nickel wire.

To Adjust Offset Voltage

RIGOL DS6000/MSO4000/DS4000 series oscilloscope can provide offset voltage to the RP7000 series active probe. The offset voltage adjusts the measured signal which exceeds the input dynamic range of the probe within an appropriate range to ensure the measured signal's integrity.

You can adjust the offset voltage by operating the front panel menu of the oscilloscope and the operation method is as shown below.

1. Connect the RP7000 series active probe to the channel input terminal (such as CH1) of the DS6000/MSO4000/DS4000 oscilloscope, referring to **To Connect to the Oscilloscope**.
2. Open the probe offset voltage control menu of the DS6000/MSO4000/DS4000 oscilloscope (front panel operation: **CH1** → **Probe** → **Bias Voltage**) and rotate the knob to adjust the value.

To Calibrate the Probe

Before using, you can use the PCK1000 active differential probe calibration kit to calibrate the RP7000 series active probe. Follow the procedures below to calibrate the RP7000 active probe using this kit:

1. Connect one connector to the calibration board and the female BNC of the cable respectively and then connect the other connector to the other part of the calibration board (called part 1).
2. Connect the RP7000 active probe to the analog channel (CH1 to CH4 of the oscilloscope, illustrations here are based on CH1).
3. Open the probe calibration control menu (front panel operation: **CH1** → **Probe** → **Probe-Cal**). At this point, calibration prompt message is displayed in the user interface of the oscilloscope. Follow the prompt message to connect part 1 to the oscilloscope. Generally, connect the BNC (male) of the connector to the corresponding analog channel and the male BNC of the cable to the **[Trig Out/Calibration]** port at the rear panel of the oscilloscope.
4. Adjust the spacing between the probe tips so as to connect the positive probe tip to the middle signal line on the calibration board and the negative probe tip to the both sides of the middle signal line. Note: it is recommended to place the probe tips at the middle of the calibration board.
5. Press **Start** and the oscilloscope starts to calibrate the probe. The

calibration will last for about 40 to 50 seconds. When probe calibration finished, "Probe calibration finished!" or "Probe calibration failure!" is displayed in the user interface of the oscilloscope. Note: to ensure the calibration precision, the probe tips must be firmly connected to the calibration board during the calibration.

Note: Relative specifications of the RP7000 series active probe depend on the calibration operation. After the calibration is finished, the DC gain, offset voltage zero and offset gain will be calibrated. User can query the information about the manufacturer, model, serial number and the last calibration time of the probe through **CH1** → **Probe** → **Probe Info**.

General Care and Cleaning

General Care:

Do not place the probe and its accessories in places where they will be exposed to sun light for long periods of time.



CAUTION

Keep the probe and its accessories away from any corrosive liquid.

Cleaning:

Clean the probe and its accessories regularly according to their operation conditions using the method below.

1. Disconnect the probe from the oscilloscope or voltage source.
2. Remove the loose dust on the exterior of the probe and its accessories using a lint-free cloth (with mild detergent or water).



WARNING

Make sure the probe is completely dry before using it to avoid short circuit and personal injuries.

Warranty

RIGOL warrants that its products mainframe and accessories will be free from defects in materials and workmanship within the warranty period.

If a product is proven to be defective within the respective period, **RIGOL** guarantees the free replacement or repair of products which are approved defective. For detailed warranty description, please refer to **RIGOL** official website or the warranty card. To get repair service or a complete copy of the warranty description, please contact with your nearest **RIGOL** sales and service office.

RIGOL does not provide any other warranty items except the one being provided by this summary and the warranty statement. The warranty items include but not being subjected to the hint guarantee items related to tradable characteristic and any particular purpose. **RIGOL** will not take any responsibility in cases regarding to indirect, particular and ensuing damage.

Specifications

Technical Specifications

Item	RP7150	RP7080
Bandwidth	>1.5GHz	>0.8GHz
Rise Time	<265ps	<465ps
System Bandwidth	1GHz (DS6104 or DS6102)	0.8GHz (DS6104 or DS6102)
Input Capacitance	<1pF	
Input Resistance	50kΩ±2% Differential 25kΩ±4% Single-ended	
Input Dynamic Range	±6.25V	
Input Common mode Range	±6.75V DC to 100Hz ±1.25V >100Hz	
Common Mode Rejection Ratio	>45dB@1MHz	
DC Attenuation	10:1 ±2%	
Zero Offset Error ^[1]	<30mV before calibration <5mV after calibration	
Offset Voltage Range	±12V	
Offset Accuracy ^[1]	<3% of current range before calibration <1% of current range after calibration	
Input Noise	45mVpp	
Propagation Delay	7ns	
Max Input Voltage	30V Peak CAT I ^[2]	
Electrostatic Protection	>8kV	

General Characteristics

Environmental Conditions	Operating	Non-operating
Temperature	+5°C to +40°C	-40°C to +70°C
Humidity	0 RH to 80% RH	0 RH to 90% RH
Altitude	4600m	15300m
Power Consumption	1.2W	N/A
Weights	147g±10g ^[3] 530g±50g ^[4]	
Wire Length	1.4m	

- [1] Typical value. The specifications would change when different scales are selected.
- [2] CAT I and CAT II Definitions
 Installation Category (Overvoltage Category) I: signal level, special equipment or parts of equipment, telecommunication, electronic, etc., with smaller transient voltages than installation category (Overvoltage Category) II.
 Installation Category (Overvoltage Category) II: local level, appliance, portable equipment etc., with smaller transient voltages than installation category (Overvoltage Category) III.
- [3] The weight of the probe with the hand-held differential probe head.
- [4] The weight of the RP7000 series Active Probe Kit with the probe bag.