

Chroma

Ground Bond Tester
19572
User's Manual

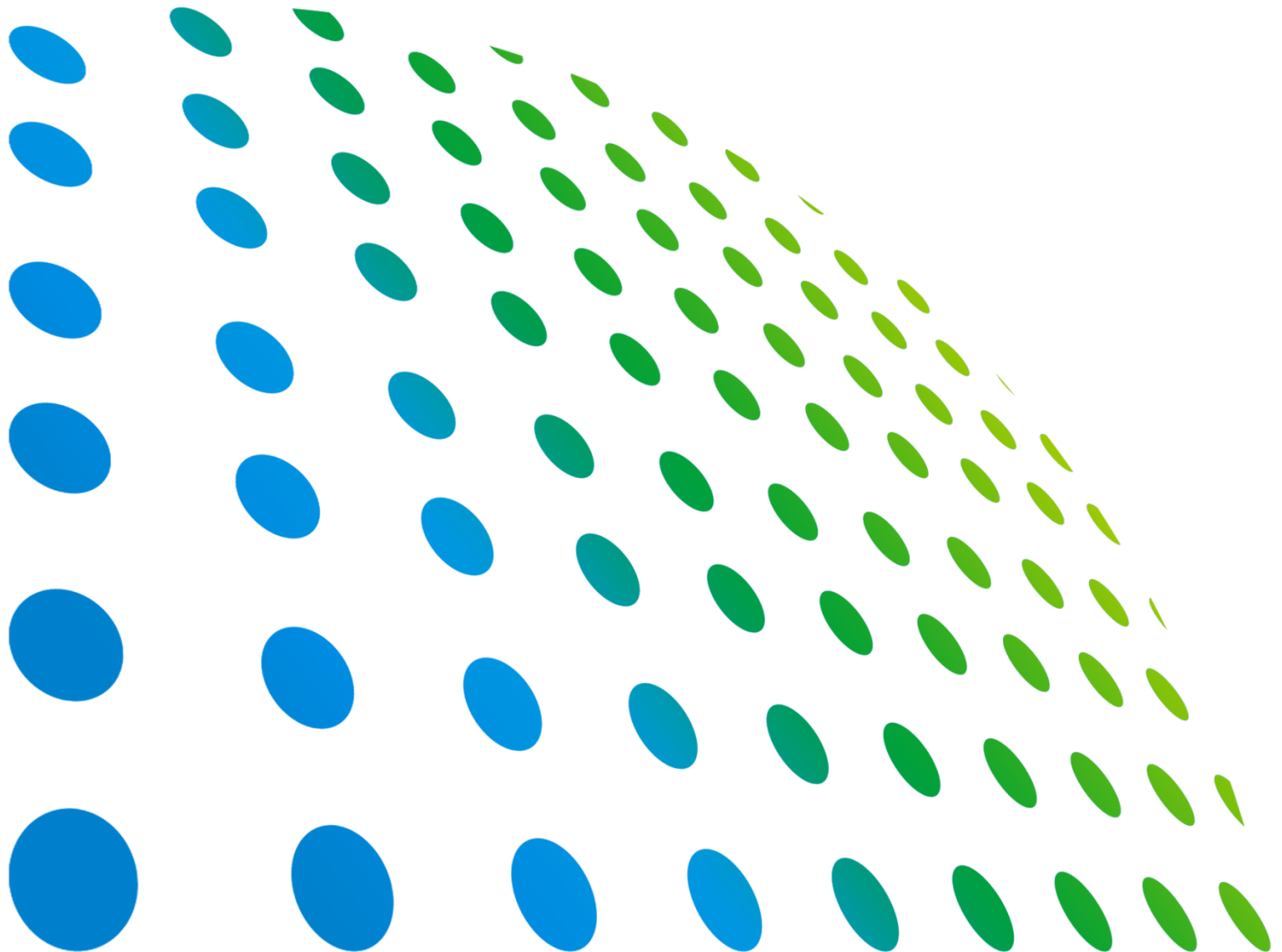

Ground Bond Tester 19572 User's Manual



Version 2.0
April 2017

Legal Notices

The information in this document is subject to change without notice.

Chroma ATE INC. makes no warranty of any kind with regard to this manual, including, but not limited to, the implied warranties of merchantability and fitness for a particular purpose. Chroma ATE INC. shall not be held liable for errors contained herein or direct, indirect, special, incidental or consequential damages in connection with the furnishing, performance, or use of this material.

CHROMA ATE INC.

66 Huaya 1st Road, Guishan, Taoyuan 33383, Taiwan

Copyright Notices. Copyright 2004 - 2017 Chroma ATE INC., all rights reserved. Reproduction, adaptation, or translation of this document without prior written permission is prohibited, except as allowed under the copyright laws.

Warranty

All of Chroma's instruments are warranted against defects in material and workmanship for a period of one year from date of shipment. Chroma agrees to repair or replace any assembly or component found to be defective, under normal use during this period. Chroma's obligation under this warranty is limited solely to repairing any such instrument, which in Chroma's sole opinion proves to be defective within the scope of the warranty when returned to the factory or to an authorized service center. Purchaser is responsible for the shipping and cost of the service item to Chroma factory or service center. Shipment should not be made without prior authorization by Chroma.

This warranty does not apply to any products repaired or altered by persons not authorized by Chroma, or not in accordance with instructions furnished by Chroma. If the instrument is defective as a result of misuse, improper repair, or abnormal conditions or operations, repairs will be billed at cost.

Chroma assumes no responsibility for its product being used in a hazardous or dangerous manner either alone or in conjunction with other equipment. High voltage used in some instruments may be dangerous if misused. Special disclaimers apply to these instruments. Chroma assumes no liability for secondary charges or consequential damages and in any event, Chroma's liability for breach of warranty under any contract or otherwise, shall not exceed the purchase price of the specific instrument shipped and against which a claim is made.

Any recommendations made by Chroma for use of its products are based upon tests believed to be reliable, but Chroma makes no warranty of the results to be obtained. This warranty is in lieu of all other warranties, expressed or implied, and no representative or person is authorized to represent or assume for Chroma any liability in connection with the sale of our products other than set forth herein.

CHROMA ATE INC.

66 Huaya 1st Road, Guishan,
Taoyuan 33383, Taiwan
Tel: 886-3-327-9999
Fax: 886-3-327-2886
e-mail: info@chromaate.com
<http://www.chromaate.com>

Material Contents Declaration

The recycling label shown on the product indicates the Hazardous Substances contained in the product as the table listed below.

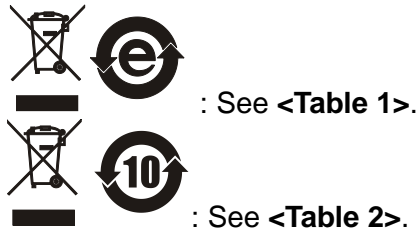

: See <Table 1>.

: See <Table 2>.

<Table 1>

Part Name	Hazardous Substances					
	Lead	Mercury	Cadmium	Hexavalent Chromium	Polybrominated Biphenyls/ Polybromodiphenyl Ethers	Selected Phthalates Group
	Pb	Hg	Cd	Cr ⁶⁺	PBB/PBDE	DEHP/BBP/DBP/DIBP
PCBA	O	O	O	O	O	O
CHASSIS	O	O	O	O	O	O
ACCESSORY	O	O	O	O	O	O
PACKAGE	O	O	O	O	O	O

“O” indicates that the level of the specified chemical substance is less than the threshold level specified in the standards of SJ/T-11363-2006 and EU Directive 2011/65/EU.

“x” indicates that the level of the specified chemical substance exceeds the threshold level specified in the standards of SJ/T-11363-2006 and EU Directive 2011/65/EU.

Remarks: The CE marking on product is a declaration of product compliance with EU Directive 2011/65/EU.

Disposal

Do not dispose of electrical appliances as unsorted municipal waste, use separate collection facilities. Contact your local government for information regarding the collection systems available. If electrical appliances are disposed of in landfills or dumps, hazardous substances can leak into the groundwater and get into the food chain, damaging your health and well-being. When replacing old appliances with new one, the retailer is legally obligated to take back your old appliances for disposal at least for free of charge.



<Table 2>

Part Name	Hazardous Substances					
	Lead	Mercury	Cadmium	Hexavalent Chromium	Polybrominated Biphenyls/ Polybromodiphenyl Ethers	Selected Phthalates Group
	Pb	Hg	Cd	Cr ⁶⁺	PBB/PBDE	DEHP/BBP/DBP/DIBP
PCBA	×	○	○	○	○	○
CHASSIS	×	○	○	○	○	○
ACCESSORY	×	○	○	○	○	○
PACKAGE	○	○	○	○	○	○

“○” indicates that the level of the specified chemical substance is less than the threshold level specified in the standards of SJ/T-11363-2006 and EU Directive 2011/65/EU..

“×” indicates that the level of the specified chemical substance exceeds the threshold level specified in the standards of SJ/T-11363-2006 and EU Directive 2011/65/EU..

1. Chroma is not fully transitioned to lead-free solder assembly at this moment; however, most of the components used are RoHS compliant.
2. The environment-friendly usage period of the product is assumed under the operating environment specified in each product's specification.

Disposal

Do not dispose of electrical appliances as unsorted municipal waste, use separate collection facilities. Contact your local government for information regarding the collection systems available. If electrical appliances are disposed of in landfills or dumps, hazardous substances can leak into the groundwater and get into the food chain, damaging your health and well-being. When replacing old appliances with new one, the retailer is legally obligated to take back your old appliances for disposal at least for free of charge.





Declaration of Conformity

For the following equipment :

Ground Bond Tester

(Product Name/ Trade Name)

19572

(Model Designation)

CHROMA ATE INC.

(Manufacturer Name)

66 Huaya 1st Road, Guishan, Taoyuan 33383, Taiwan

(Manufacturer Address)

Is herewith confirmed to comply with the requirements set out in the Council Directive on the Approximation of the Laws of the Member States relating to Electromagnetic Compatibility (2014/30/EU) and Low Voltage Directive (2014/35/EU). For the evaluation regarding the Directives, the following standards were applied :

EN 61326-1:2013, Table 2, CISPR 11:2009+A1:2010, Group 1 Class A

EN 61000-3-2:2006+A1:2009+A2:2009, Class A, EN 61000-3-3:2013

IEC 61000-4-2:2008, IEC 61000-4-3:2006+A1:2007+A2:2010, IEC 61000-4-4:2012,

IEC 61000-4-5:2005, IEC 61000-4-6:2008, IEC 61000-4-8:2009, IEC 61000-4-11:2004

EN 61010-1:2010

The equipment describe above is in conformity with Directive 2011/65/EU of the European Parliament and of the Council of 8 June 2011 on the restriction of the use of certain hazardous substances in electrical and electronic equipment.

The following importer/manufacturer or authorized representative established within the EUT is responsible for this declaration :

CHROMA ATE INC.

(Company Name)

66 Huaya 1st Road, Guishan, Taoyuan 33383, Taiwan

(Company Address)

Person responsible for this declaration:

Mr. Vincent Wu

(Name, Surname)

T&M BU Vice President

(Position/Title)

Taiwan

(Place)

2017.02.21

(Date)

(Legal Signature)

Safety Summary

The following general safety precautions must be observed during all phases of operation, service, and repair of this instrument. Failure to comply with these precautions or specific WARNINGS given elsewhere in this manual will violate safety standards of design, manufacture, and intended use of the instrument. *Chroma* assumes no liability for the customer's failure to comply with these requirements.



BEFORE APPLYING POWER

Verify that the power is set to match the rated input of this power supply.



PROTECTIVE GROUNDING

Make sure to connect the protective grounding to prevent an electric shock before turning on the power.

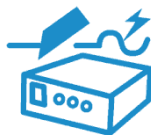

NECESSITY OF PROTECTIVE GROUNDING

Never cut off the internal or external protective grounding wire, or disconnect the wiring of protective grounding terminal. Doing so will cause a potential shock hazard that may bring injury to a person.



FUSES

Only fuses with the required rated current, voltage, and specified type (normal blow, time delay, etc.) should be used. Do not use repaired fuses or short-circuited fuse holders. To do so could cause a shock or fire hazard.



DO NOT OPERATE IN AN EXPLOSIVE ATMOSPHERE













Do not operate the instrument in the presence of flammable gases or fumes. The instrument should be used in an environment of good ventilation.



DO NOT REMOVE THE COVER OF THE INSTRUMENT

Operating personnel must not remove the cover of the instrument. Component replacement and internal adjustment can be done only by qualified service personnel.

Safety Symbols

	DANGER – High voltage.
	Explanation: To avoid injury, death of personnel, or damage to the instrument, the operator must refer to the explanation in the instruction manual.
	High temperature: This symbol indicates the temperature is hazardous to human beings. Do not touch it to avoid any personal injury.
	Protective grounding terminal: This symbol indicates that the terminal must be connected to ground before operation of the equipment to protect against electrical shock in case of a fault.
	Functional grounding: To identify an earth (ground) terminal in cases where the protective ground is not explicitly stated. This symbol indicates the power connector does not provide grounding.
	Frame or chassis: To identify a frame or chassis terminal.
	Alternating Current (AC)
	Direct Current (DC) / Alternating Current (AC)
	Direct Current (DC)
	Push-on/Push-off power switch
	The WARNING sign highlights an essential operating or maintenance procedure, practice, condition, statement, etc., which if not strictly observed, could result in injury to, or death of, personnel or long term health hazards.
	The CAUTION sign highlights an essential operating or maintenance procedure, practice, condition, statement, etc., which if not strictly observed, could result in damage to, or destruction of, equipment.
	The Notice sign highlights an essential operating or maintenance procedure, condition, or statement.

Inspection and Examination

Before the instrument exit the factory, we have a series of inspection and measurement on mechanical and electrical characteristics. Make sure its function of operating for the quality warranty of the product. If collision results in damages and defects of the quality and the performance, please contact us for promptly service.

Standard Accessory

Item	Q'ty	Remark
Power cord	1	90° elbow USA-type power cord, length 1.8m
3P – 2P adapter	1	USA-type power cord 3P – 2P adapter
GB test cable	1	Wire used in GC test, length 1m- Max. 45A (1 pair has 2 wires in total)
10A fuse	1	10A SLOW 110VAC used
5A fuse	1	5A SLOW 240VAC used
Quick Start Guide	2	One English version and one Traditional Chinese version
User's manual CD	1	CD for user's manuals in English and Traditional Chinese



Notice

The detailed about using the notice items and the danger of operating are described in *Chapter 3 "Notices before Using"* of this manual.

Storage, Freight, Maintenance & Cleaning

Storage

When don't use the device, please pack it properly and store under a good environment. (The packing is no needed when the device under appropriate environment.)

Freight

Please use the original packing material when move the device. If the packing material is missing, please use the equivalent buffer material to pack and mark it fragile and waterproof etc to avoid the device damage during movement. The device belongs to precise equipment, please uses qualified transportation as possible. And avoid heavy hitting etc to damage the device.

Maintenance

There is no maintenance operation for the general users. (Except for the note in the manual.) Please contact our company or agent when the device occurred the user judgment abnormal. Don't maintain by yourself to avoid occurred unnecessary danger and serious damage to the device.

Cleaning

Remove all connected wires and cables on the instrument before cleaning. Use a brush gently to clean the dust on it. For internal cleaning, use a low-pressure air gun to vacuum the dust inside or send it back to the distributors or agents of Chroma for cleaning.

Revision History

The following lists the additions, deletions and modifications in this manual at each revision.

Date	Version	Revised Sections
April 2004	1.0	Complete this manual
June 2004	1.1	Modify "SYSTEM Setup" "How to Enter Memory Process" "Store Memory" "PROGRAM Setting" "Test Procedures" Delete "How to Select Memory"
May 2005	1.2	Change the address and phone number of Chroma
March 2007	1.3	Add " <i>Material Contents Declaration</i> " Delete the description of Disposal in " <i>Storage. Freight. Maintenance. Disposal</i> "
Feb. 2008	1.4	Add the following: <ul style="list-style-type: none"> - "CE" Certification. - description of SCPI command in the section of "<i>Command Summary</i>" and "<i>Command Description</i>".
May 2011	1.5	Add UL/TUV required descriptions. Modify " <i>Material Contents Declaration</i> ".
Mar. 2012	1.6	Modify <ul style="list-style-type: none"> - "<i>CE Declaration</i>". - Figure 4-4 in the section of "<i>Remote Control</i>". - the description of "Time T2" in the section of "<i>Timing Diagram</i>".
Mar. 2013	1.7	Modify "5. GB VOLTAGE 8.0V" on the display screen to "6.0V" in the section of " <i>How to Enter PRESET Setting Menu</i> ".
Sep. 2016	1.8	Modify " <i>CE Declaration of Conformity</i> ".
Dec. 2016	1.9	Modify the following: <ul style="list-style-type: none"> - Rear panel figure in the section of "<i>Rear Panel</i>". - Figure 4-1, figure 4-2, figure 4-3 and figure 4-4 in the section of "<i>Remote Control</i>". - the description of table and timing diagram in the section of "<i>Timing Diagram</i>". Delete FAIL descriptions in the sections of " <i>Rear Panel</i> " and " <i>Output Signal</i> ".
Apr. 2017	2.0	Modify the following: <ul style="list-style-type: none"> - "<i>Material Contents Declaration</i>". - "<i>CE Declaration of Conformity</i>". Add " <i>User Manual Customer Feedback</i> ".

Table of Contents

1. Introduction	1-1
1.1 An Overview of Product.....	1-1
1.2 Features.....	1-1
2. Specifications (18°C ~ 28°C RH ≤ 70%)	2-1
3. Notices before Using	3-1
4. Panel Description	4-1
4.1 Front Panel	4-1
4.2 Rear Panel	4-2
4.3 Notices and Procedures before Operation.....	4-3
4.4 SYSTEM Setup	4-4
4.4.1 How to Enter SYSTEM Menu	4-4
4.4.2 Operation Method.....	4-4
4.5 Memory Management	4-5
4.5.1 How to Enter Memory Process	4-5
4.5.2 Delete Memory	4-5
4.5.3 Recall Memory.....	4-6
4.5.4 Store Memory	4-6
4.6 PRESET Testing.....	4-6
4.6.1 How to Enter PRESET Setting Menu.....	4-6
4.6.2 Operation Method.....	4-7
4.7 PROGRAM Setting.....	4-7
4.7.1 Test Procedure Setting	4-7
4.7.2 Operation Method.....	4-8
4.7.3 Each Parameter Setting Data Description.....	4-9
4.8 How to Process Test.....	4-9
4.8.1 Offset Value Calibration of Test Cable.....	4-9
4.8.2 Connecting DUT Methods.....	4-9
4.8.3 Test Procedures.....	4-10
4.9 KEY LOCK Function.....	4-10
4.9.1 KEY LOCK Setting	4-10
4.9.2 Canceling KEY LOCK.....	4-11
4.10 User Password Setting.....	4-12
4.11 Remote Control	4-12
4.12 Output Signal	4-14
4.13 Timing Diagram	4-15
5. Remote Interface Description	5-1
5.1 RS232 Interface Specification	5-1
5.1.1 Data Format	5-1
5.1.2 Command Format.....	5-1
5.1.3 Connector.....	5-1
5.1.4 Connection Method	5-2
5.2 Remote Interface Command	5-2
5.2.1 Command Summary.....	5-2
5.2.2 Command Description	5-5
5.2.3 SCPI Status System	5-12
5.3 Error Messages.....	5-13
5.4 RS232 Operation Using Basic.....	5-14
6. GPIB Description (Option)	6-1
6.1 Guide	6-1

6.2	Interface Specification	6-1
6.2.1	Applicable Standard	6-1
6.2.2	Interface Capability	6-1
6.2.3	Using Code	6-1
6.3	GPIB Related Panel Description	6-2
6.3.1	Address Setting	6-2
6.3.2	Remote / Local	6-2
6.4	Interface Message	6-3
6.5	GPIB Control / Setting Command Descriptions	6-3
7.	Printer Function (Option)	7-1
8.	Calibration Procedure	8-1
8.1	Calibration Menu	8-1
8.2	Start Calibration	8-1
8.3	Complete Calibration	8-2
9.	INTERLOCK OPEN, Various Status Definition of Tester	9-1
9.1	Before Testing	9-1
9.2	Under Test	9-1
9.3	STEP HOLD TIME \neq KEY, FAIL CONT. = OFF	9-1
9.4	STEP HOLD TIME = KEY, FAIL CONT. = OFF	9-1
9.5	STEP HOLD TIME \neq KEY, FAIL CONT. = ON	9-2
9.6	STEP HOLD TIME = KEY, FAIL CONT. = ON	9-2
10.	GBSS MODE	10-1
11.	Maintenance	11-1
11.1	General	11-1
11.2	Cleaning	11-1
11.3	Battery Replacement	11-1
11.4	Instrument Return	11-1

1. Introduction

1.1 An Overview of Product

This automatic ground bond tester is designed to test ground resistance automatically for electrical machinery and electronic devices. For ground resistance, its test range is from 0~140mΩ, under 10A can up to 510 mΩ. The output test current range is 3~45A can be set arbitrarily.

1.2 Features

1. Clear Display

This instrument has the clearest design for setting the parameters of current states, time, readings, memory no., procedures and states. All of them can be read from the display directly.

2. Memory Backup

This instrument will backup the data after setting parameters save to the memory. The data remain in the memory even though open the data after power-off. Therefore, if the data is not necessary to backup, please don't save to the memory avoid occupying memory space.

3. High/Low Limit Comparison for Pass/Fail Judgment

The function of high/low limit comparison for Pass/Fail judgment is designed for preventing the misjudgment due to bad connection or test cable tripped. This function is able to detect if there is any bad connection or broken line.

4. Software Calibration

Use software to calibrate. It is no need to open cover, key in correct value by using keyboard on panel completely. The calibration value saves in EEPROM. The calibration result is correct, stable.

5. Remote Control

This instrument can extend [START] and [STOP] signals to control externally.

6. The Output of Test Result Signal

The test result can output by relay point on method, such as PASS, FAIL and TEST signals output.

7. Keypad Locked Function

All of keypads are locked except for [STOP] in test state.

8. OFFSET Calibration Function

This instrument is with Offset Get function. This function can read OFFSET of test terminal, line impedance of ground test under test status and then save in the memory. Automatic deduction each test makes the test value more correct.

2. Specifications (18°C ~ 28°C RH ≤ 70%)

□ Ground Bond Tester	
□ Output Current	3.00 ~ 45.0A AC (Note1, 2).
□ Resolution	3.00A ~ 30.00A 0.01A 30.1A ~ 45.0A 0.1A
□ Accuracy	± (1.5% of setting + 0.5% of full scale)
□ Output Frequency	50Hz, 60Hz
□ Accuracy	± 0.1%
□ Current Meter	0.01 ~ 45.0A
□ Resolution	3.00A ~30.00A 0.01A 30.1A ~ 45.0A 0.1A
□ Accuracy	± (1.5% of reading + 0.5% of full scale)
□ Resistance Range	0.1 ~ 510.0mΩ (Note2)
□ Resolution	(R display counts/ I display counts) ≥ 0.2, Resolution: 1mΩ (R display counts/ I display counts) < 0.2, Resolution: 0.1mΩ
□ Accuracy (Note3)	± (2% of reading + 0.5% of full scale), Detail Spec. Range
□ Limit Value Setting	HI – LIMIT: 0.1 ~ 510.0mΩ LOW–LIMIT: OFF, 0.1mΩ ~ HI – LIMIT Value, 510.0mΩ MAX.
□ Offset Function	
□ Offset Range	0 ~ 100.0mΩ
□ Test Time	0.5 ~ 999.0 sec. Continue (Note2)
□ Resolution	0.1sec
□ Memory Storage	
□ Memories, Steps	10 steps or 99 groups for total 500 memory locations

□ Ambient Temperature and Relative Humidity	
□ Specifications Range	18 to 28°C (64 to 82°F), ≤ 70% RH.
□ Operable Range	Maximum relative humidity 80% for temperature up to 31°C (88°F). Decreasing linearly to 50% relative humidity at 40° C (104°F) Altitude up to 2000m. Indoor use only. Pollution degree 2
□ Storage Range	-10 to 60°C (-14 to 140°F), ≤ 90% RH.
□ Installation Category	CAT II
□ Power Requirement	
□ Line Voltage	AC 100V, 120V, 220V ± 10%, 240V -10% ~ +5%
□ Frequency	50 or 60 Hz
□ Power Consumption	No load: < 100VA, With rated load: 880W MAX.
□ Dimension	320W x 105H x 400D mm
□ Weight	< 16 kg.
□ Safety	
□ Ground Bond	Less than 100mΩ at 25Amp, 2sec
□ Hipot	Less than 5mA at 1.8kVac, 3sec
□ Insulation Resistance	Over 20MΩ at 500V 3sec
□ Line Leakage Current	Less than 3.5mA at 127V, 2sec, normal, reverse

Note

1. For full rating output, the line input range is +10%, -5%.
2. 40 amp for TUV 120 seconds, 40.1 – 45amp continue is 60 seconds.
The maximum test resistance range is with offset value 510mΩ, at 8amp output.
3. For getting the optimal accuracy, please use the 4-wire type for measuring.
It is no need to do offset again. When offset value is lower than 10mΩ, it is over test specification. By using offset can increase 5mΩ maximum specifications error.

3. Notices before Using

Please read through the notices described in this chapter and memorize them to prevent any accidents from happening.

■ Induction and electric shock

To avoid electric shock, please check the power of the tester related settings and descriptions firstly before operating the tester.

■ Grounding

There is a safety grounding terminal at the instrument rear panel. Please use appropriate test leads and tools to connect the grounding terminal surely. If it is not grounding correctly, the chassis of test machine may contain high voltage when the power circuit or the connecting line of any devices short-circuited with the grounding terminal. This is very dangerous as it may cause electric shock if anyone touches the instrument under the circumstances. Therefore, it is necessary to connect the safety grounding terminal to earth correctly.

■ Remote control system

This system is capable of remote control. Usually it uses control signal of rear panel coordinating with HI-POT series model (such as 1905X, 1907X) to do the high voltage output control. For your safety and to prevent accidents, the following principles of control must be performed accurately.

- Do not allow any unexpected high voltage output to cause any hazards.
- When the system has high voltage output, operators and other personnel are not allowed to touch the DUT, test cable and probe and output terminal, etc.

■ Turn the power switch on or off ※ Caution ※

The product should be so positioned that the power switch can be easily reached by the operator during emergency. Once the power switch is cut off, wait a few seconds to turn it on again. Do not turn on/off the power switch repeatedly to avoid causing any errors.

■ Miscellaneous notices

Do not short circuit the instrument output line, grounding line, transmission line, or other connector grounding line, and AC source to avoid the entire test device being charged to a very dangerous voltage. If the tester is under full load output for a long period, the bottom partial site of the tester may be high temperature over 50°C. Before moving the tester, please power the tester off firstly as well as confirm the bottom site of the tester decrease to below 30°C for avoiding the danger of burning.

■ Installation notices

When installs or operates the tester, the ventilation holes should be at least 10cm from wall to keep adequate ventilation.

<<< Emergency Events >>>

■ Emergency management

In the emergency situations of electric shock, DUT on fire or system on fire, follow the steps below to avoid causing bigger hazards.

- First, cut off the power switch.
- Then, unplug the power cord.

■ DANGER indicator failure

If you press the [START] button and the current meter shows readings but the DANGER indicator is still off, it means the indicator may be failure. Turn the instrument off and replace it immediately, then return the malfunction device to Chroma or dealer for repair and services.

■ **There are four types of AC INPUT power source used in this instrument**

Switch the voltage selector on the rear panel to the correct position according to the voltage used locally. Ensure the AC power source is same as marked on the power switch that located on the rear panel, and the fuse is changed to the appropriate one when plug in the power cord. Following table lists the fuses for the voltage used:

Mark	Center Voltage	Range	Fuse
100	100V	90V ~ 110V	10A Slow/250V
120	120V	110V ~ 130V	10A Slow/250V
220	220V	200V ~ 240V	5A Slow/250V
240	240V	220V ~ 250V	5A Slow/250V

The fuse should conform to the voltage used and replace it when the power cord is unplugged to avoid electric shock. Use a flat screwdriver to pull open the fuse holder inside the power socket, remove the existing fuse and insert the new one, then plug in the power cord.

⚠ WARNING Be sure to use correct fuse when changing it, or it may cause danger easily.

■ **This instrument operates in AC power source**

If the power source is unstable in the range selected, it may cause the instrument to act abnormally or inaccurately. Please use appropriate equipment such as power regulator to convert it to applicable power source.

■ **Storage**

The normal temperature range is 0°C ~ 40°C, 80% RH. The operation may incorrect if over the range. The storage temperature is - 10°C ~ 60°C, 90% RH. If you are not planning to use it for a long period of time, pack it with the original box for storage. For the sake of correct test and safety of this instrument, make sure not to store it in a place with direct sunlight or high temperature, also away from shaky, damp and dusty area.

■ **Warming up**

This instrument activates at power on; however, in order to meet the accuracy specified in the specification, please warm it up for 15 minutes or above.

4. Panel Description

4.1 Front Panel

Front panel includes several function areas easy to use. This chapter will introduce each control and information on screen to you.

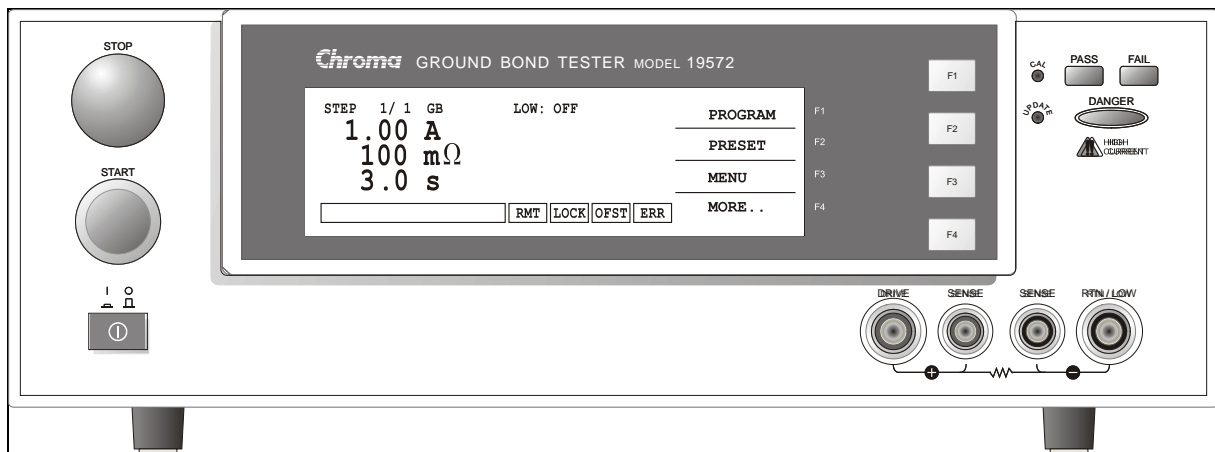

Display Area

Function Key: There are different function descriptions under different screens. The corresponding function keys (F1-F4) are on the right side of display. If the description part is blank, it means the corresponding function key is invalid.

Status List: It indicates setting method, setting value range, test result fail status.

RMT: If **RMT** is highlighted, it means the main machine under Remote state. The main machine is controlled by PC through GPIB/RS232 connection line. All of keys are loss function except for [STOP], [Local] and [MORE..].

LOCK: If **LOCK** is highlighted, it means the main machine under setting parameter protection state. All of modes can't enter except for three modes – "MEMORY", "TEST" and "KEY LOCK".

OFST: If **OFST** is highlighted, it means the tester zeroed the resistance of test lead.

ERR: If **ERR** is highlighted, it means there are unclear errors in error queue.

DANGER LED: The test status indicator. When LED is light, it means the tester is under testing status. Don't touch the test terminal when there is high voltage or mass current output.

PASS LED: Pass indicator. DUT judged as pass when the LED is light.

FAIL LED: Fail indicator. DUT judged as fail when the LED is light. Cut off the output of main machine when DUT judged as fail. The LED is still lighting until press [STOP].

Keypad Area

Power Switch: The power switch provides AC source the tester needed.

STOP Key: Reset key, after pressing this key the main machine return to standby test status immediately. That is cut off output and clears all of judgments simultaneously.

START Key: After pressing this key, the main machine is under test. The test terminal has

output and each judgment function start simultaneously.

Cal-Enable: Calibration switch. This key is only for calibration before exiting factory. A non-professional personnel using this function is prohibited or may cause the product malfunction.

UPDATE: This key is for updating the program before exiting from the factory. Non-professional is prohibited to use this function, or may cause the tester malfunction.

Function Keys: Function keys F1 ~ F4, there are different functions under different display menus. The corresponding function key is at the right side of display. If the description part is blank, it means the corresponding function key is invalid.

Terminal Area

Drive (+): Positive electric potential of mass current output.

Sense (+): The grounding impedance testing positive terminal.

Sense (-): The grounding impedance test negative.

RTN/LOW: Common test terminal. It is mass current output negative terminal also is low potential terminal. This terminal is almost equivalent to chassis ground terminal.

4.2 Rear Panel

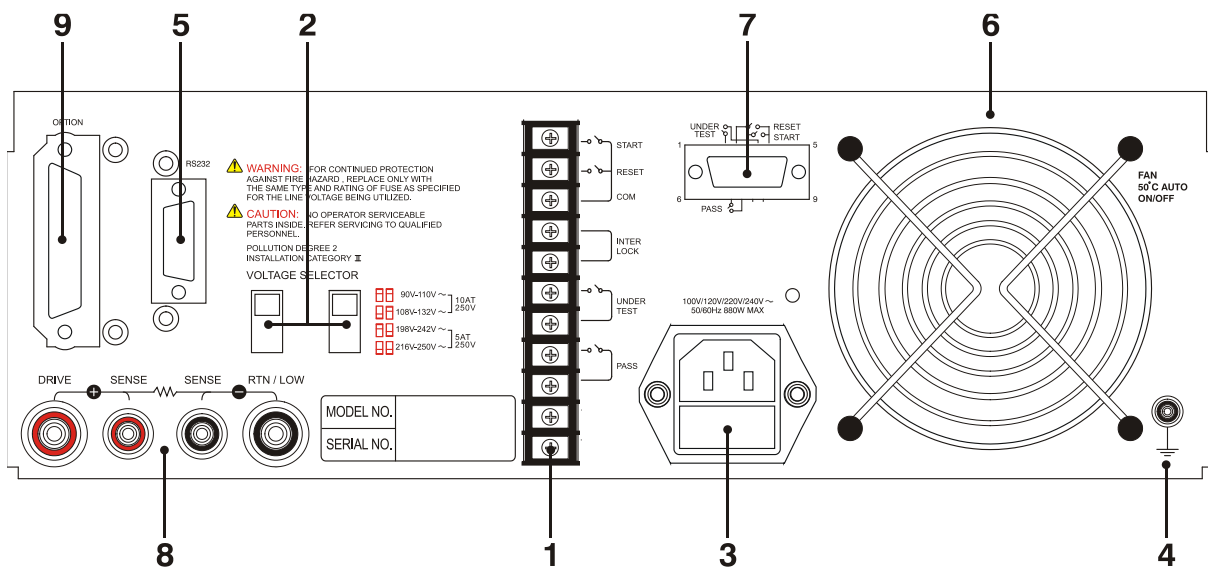

(1) REMOTE I/O PORT 1: The remote input/output port 1.

START : Start test signal input terminal.

STOP : Stop test signal input terminal.

INTER LOCK : Output high voltage only when this two terminals are short-circuited.

UNDER TEST: When the tester is under testing, this output terminal will be short-circuited.

Control external signal by using this short condition. The junction specification 30V AC or 60V DC current is less than 0.3A action time.

The tester is under testing until be stopped.

PASS : When the tester judge DUT as pass, this output terminal will be short-circuited. User specifies the time of short circuit. Control external signal by using this short circuit condition. The junction specification 30V AC or 60V DC current is less than 0.3A action time. The product judge as pass until is stopped.

- (2) VOLTAGE SELECTOR:** Input Power Range Switch
Change the tester inputted AC power. AC power by using has below four kinds.
- 110V applicable voltage range 90 ~ 110V AC
 - 120V applicable voltage range 100 ~ 130V AC
 - 220V applicable voltage range 200 ~ 240V AC
 - 240V applicable voltage range 220 ~ 250V AC
- As changing this power switch, please notice replacement of fuse.
- (3) AC LINE:** AC power socket and fuse holder.
A tri-cord power and fuse holder. Input AC power the tester needed from AC power socket. The detailed specification of using fuse, please refers "*Chapter 3 – Notices before Using*" or descriptions of rear panel in this manual.
- (4) GROUND:** Safety ground terminal, please use applicable implement to connect this ground terminal actually. If there is no grounded to earth actually, the circuit or other instruments connection line with ground terminal is short-circuit. The chassis of tester may exist high voltage. This is very dangerous, anyone touch the tester under the above state may cause shock hazard. Therefore, please be sure to connect safety ground terminal to earth.
- (5) RS232 INTERFACE:**
This socket is for RS232 interface. GPIB and RS232 interface can't use simultaneously.
- (6) FAN :** The temperature controlled fan, as temperature reaches 50°C, fan opens automatically. When the temperature is lower than 45°C, fan stops automatically.
- (7) REMOTE I/O PORT 2:** The remote input/output port 2.
All functions of 9pin D-Sub connector are the same as (1) Remote I/O port 1.
- (8) Terminal Area of Rear Panel**
The function of this area is the same as terminal area on front panel.
- (9) OPTION INTERFACE**
This interface is for the users to purchase GPIB CARD or PRINTER CARD. GPIB CARD can use computer by GPIB (IEEE 488-1978) interface to remote control and data transfer. PRINTER CARD can plug in CENTRONICS PORT printer with DOS support mode direct to print test parameters and results of the tester.

4.3 Notices and Procedures before Operation

- Before plug in AC power cord, please confirm power used to meet to marked power on the rear panel firstly and power switch is OFF status.
- Before power on, please peruse "*Chapter 3 – Notices before Using*" and memorize it.
- When power on, the tester will self-test. If there is abnormal condition, please turn off switch and pull off power cord immediately.

4.4 SYSTEM Setup

4.4.1 How to Enter SYSTEM Menu

- Under power on screen, press Function Key [MENU] to display the menu below:

1. MEMORY						UP
2. SYSTEM						DOWN
3. OPTION						SELECT
4. CALIBRATION						
5. KEY LOCK						
SELECT FUNC.	RMT	LOCK	OFST	ERR		EXIT

6. CHANGE PASSWORD						UP
7. ERROR LOG						DOWN
8. PRINT PROGRAM						SELECT
9. ABOUT						
10. VERSION						
SELECT FUNC.	RMT	LOCK	OFST	ERR		EXIT

- Move the highlight to "SYSTEM" by using Function Key [UP], [DOWN]. Press Function Key [SELECT] to enter SYSTEM SETUP menu, display the menu below:

1. CONTRAST	:	11				UP
2. BEEPER VOL.	:	HIGH				DOWN
3. PASS ON	:	CONT.				ENTER
1-16	RMT	LOCK	OFST	ERR		EXIT

4.4.2 Operation Method

- Enter SYSTEM SETUP screen, press function Key [ENTER] to move the highlight to the parameter you want to set.
- Press function Keys [UP], [DOWN] to set this parameter.

System parameter setting description table

Setting Item	Range	Initial Setting	Description
Contrast	1~16	7	Adjust LCD brightness
Beeper Vol.	LOW / MEDIUM / HIGH / OFF	HIGH	Adjust buzzer volume
Pass ON	0, 0.1 ~ 99.9 s (0: CONT.)	CONT.	When test result is PASS, sets the time of "Pass Relay ON" on rear panel.

4.5 Memory Management

4.5.1 How to Enter Memory Process

- In power on menu, press Function Key [MENU] to display the menu below:

1. MEMORY	UP
2. SYSTEM	DOWN
3. OPTION	SELECT
4. CALIBRATION	
5. KEY LOCK	
SELECT FUNC.	RMT LOCK OFST ERR EXIT

- Move the highlight to "Memory" by using Function Key [UP], [DOWN]. Press Function Key [SELECT] to enter Memory management mode and is shown as below menu.

1. (0)	STORE
2. (0)	RECALL
3. (0)	DELETE
4. (0)	
5. (0)	
SELECT FUNC.	RMT LOCK OFST ERR EXIT

- At the same time, follows the instruction of Function Key can recall, store or delete this memory.
- The value in () means the test step numbers included in the memory.

4.5.2 Delete Memory

If you want to delete the test parameter stored in the memory. Please follow the procedures below to process.

- When the status list shows "SELECT FUNC.", press Function Key [DELETE].
- By using Function Key [UP], [DOWN] to select the test parameter data of the memory

which want to delete. Press Function Key [SELECT] will show a delete confirmation screen.

3. Press Function Key [YES] to confirm or press Function Key [NO] to cancel.

4.5.3 Recall Memory

If there are a lot of test parameter values in the main memory. Follow the below procedures to recall test parameter.

1. When the status list shows "SELECT FUNC.", press Function Key [RECALL].
2. By using Function Key [UP], [DOWN] to select the test parameter data of the memory which want to recall.
3. Press Function Key [SELECT] will show a recall confirmation window.
4. Press Function Key [YES] to confirm or press Function Key [NO] to cancel.

4.5.4 Store Memory

If you want to store the test parameter set in the memory. Please follow the procedures below to process.

1. When the status list shows "SELECT FUNC.", press Function Key [STORE] .
2. By using Function Key [UP], [DOWN] to select the memory which want to store. Press Function Key [SELECT] the highlight becomes a blinking underline.
3. By using Function Key [UP], [DOWN] to input the memory name in the meantime.
4. By using Function Key [ENTER] to move the blinking underline highlight to the next position of character.
5. If press Function Key [ENTER] twice continuously, and then will show a store confirmation window.
6. Press Function Key [YES] to confirm or press Function Key [NO] to cancel.

 **CAUTION** : If there is data in the memory, it will be overlapped. Please confirm carefully before storing.

4.6 PRESET Testing

4.6.1 How to Enter PRESET Setting Menu

1. In power on menu, press Function Key [PRESET] then enter PRESET setting menu, the menu display as below:

1.PASS HOLD	:	0.5	sec	UP
2.STEP HOLD	:	0.2	sec	DOWN
3.JUDG. WAIT	:	0.3	sec	ENTER
4.GB FREQ.	:	60	Hz	
5.GB VOLTAGE	:	6.0	V	
0.2-99.9		RMT	LOCK	OFST
		ERR	EXIT	

4.6.2 Operation Method

1. After entering PRESET menu, move the highlight to the parameter to be set by pressing [ENTER].
2. Press Function Keys [UP] or [DOWN] to set the parameter.

Preset parameter functions table:

Setting Item	Range	Initial Setting	Description
PASS HOLD	0.2 ~ 99.9	0.5	When the test result is PASS, set the buzzer continuous time.
STEP HOLD	0 ~ 99.9 / 0 = KEY	0.2	It sets interval time between test procedures. Key: It sets test procedure interruption (Please press [START] to continue when the test is stopped.)
JUDG. WAIT	0.1 ~ 99.9	0.3	It sets not to judge time.
GB FREQ.	50/60	60	It sets output voltage frequency when testing ground conduction.
GB VOLTAGE	1 - 8	6	It sets output voltage for ground conduction test.
SOFT. AGC	ON/OFF	ON	It sets if software automatic gain compensation function is open.
FAIL CONT.	ON/OFF	OFF	It sets if continue the next step after NG is occurred.
SCREEN	ON/OFF	ON	It sets if test screen to be displayed.
SMART KEY	ON/OFF	OFF	It sets if open parameter memory function.
START WAIT	0-99.9/0=OFF	OFF	It sets start test wait time.
PART NO.	Maximum 13 characters	NONE	It sets product part number.
LOT NO.	Maximum 13 characters	NONE	It sets product lot number.
SERIAL NO.	Maximum 13 characters	NONE	It sets product serial number format and * indicates changeable character. The product serial number should be 5 characters at least and can't be all *.

4.7 PROGRAM Setting

4.7.1 Test Procedure Setting

1. In power on menu, press Function Key [PROGRAM] then enter PROGRAM setting menu, the menu display as below:

STEP 1 GB		LOW : OFF				UP
CURR :	3.00A					MORE..
HIGH :	500mΩ					ENTER
TIME :	3.0s					
PROCESS STEP	RMT	LOCK	OFST	ERR	EXIT	

2. Enter PROGRAM setting menu, the test procedures increase by using Function Key [UP], the range is from 1~99.
3. Press [ENTER] to move the highlight to the other parameter want to set.
4. Can switch Function Key menu by using Function Key [MORE..], as shown below:

STEP 1 GB		LOW : OFF				DELETE
CURR :	3.00A					INSERT
HIGH :	500mΩ					DOWN
TIME :	3.0s					
PROCESS STEP	RMT	LOCK	OFST	ERR	MORE..	

5. By using Function Key [DOWN] can decrease the test step want to set, the range is 1~99.
6. By using Function Key [DELETE] and [INSERT] can delete and insert a test step.
7. Press Function Key [MORE..] can return to the previous Function Key menu, and continue to set the other test parameter.

4.7.2 Operation Method

1. Enter PROGRAM setting menu, move the highlight to the parameter you want to set by pressing [ENTER].
2. Press Function Key [UP] or [DOWN] to set the parameter.

4.7.3 Each Parameter Setting Data Description

The following are the parameter setting data of each test mode.

Ground resistance test mode (GB)

STEP 1	GB	LOW :	OFF			UP
CURR :	3.00A					DOWN
HIGH :	100mΩ					ENTER
TIME :	3.0s					
3.00-45.0A	RMT	LOCK	OFST	ERR		EXIT

CURR : Set ground resistance test needed current.

Note : Because the test current multiply the high limit of resistance can't more than 6.3V. High limit of resistance will be auto modify to adaptable value when it isn't correspondence with the above condition.

HIGH : Set ground resistance high limit value, the value is 510mΩ or minor value in 6.3V/ CURRENT.

LOW : Set ground resistance low limit value, the value is less than high limit value of ground resistance or OFF.

TIME : Set test needed time, input 0 means continuous test.

4.8 How to Process Test

4.8.1 Offset Value Calibration of Test Cable

1. In power on menu, enter multi-groups STEPS test menu by pressing Function Key [MORE..].
2. Press Function Key [OFFSET], the display will show the menu to indicate the user to connect the test cable of grounding test applicable to (+), (-) two terminals of DRIVE and SENSE, then short-circuit the test cable.
3. Press [START], DANGER LED lights on front panel. The current output time is the users' setting test time. If the test time is CONT., the current output time is five seconds. The main system start to measure line resistance of test cable and show the value on the display then store in the memory.

4.8.2 Connecting DUT Methods

Ground resistance test mode (GB)

First of all, confirms there is no current output and DANGER LED isn't light, screws the test cable and terminal up by using tool and then clipping DUT by test cable.

4.8.3 Test Procedures

1. Follows DUT connection method to connect correctly.
2. In power on menu (as below),

Line 1	STEP 1/2 GB	LOW : 0.1mΩ	PROGRAM
Line 2	3.00A		PRESET
Line 3	100mΩ		MENU
	3.0s		MORE..
		RMT	LOCK
		OFST	ERR

Description:

STEP 1/2 means there are two test procedures, now is going to perform the first test procedure. "Line 1" means test current setting value, "Line 2" means the high limit of grounding resistance, "Line 3" means test time, the test result shows on status line.

1. Please press [STOP] ready for testing, the status line shows "STANDBY".
2. Press [START] to start test.
When press this key, it will start test current output. The DANGER LED light up in the meantime, the status line show "UNDER TEST". Warning: Now is test status with mass current output. "Line 1" shows the output current reading. "Line 2" shows the measured resistance reading. "Line 3" the timer doing count down simultaneously.
3. Pass judgment
When all of test states have been tested and the test result shows PASS, then the main machine is judged as PASS and cut off output. The rear panel output PASS signal and the buzzer functioning simultaneously.
4. Fail judgment
If the measurement value is abnormal, the main machine is judged as FAIL and stop output immediately. The rear panel output FAIL signal and the buzzer functioning simultaneously. Keep on function until [STOP] key is pressed. The test result will show Fail state.

Fail state description table

Test result	Meaning
HI	Measurement resistance value is over high limit
LO	Measurement resistance value is over low limit
ADV OVER	Current reading is over hardware valid digit.
ADI OVER	Resistance reading is over hardware valid digit.
CAN NOT TEST	Do not set the output current value or the measured resistance high limit value.

Under any circumstance, if the test output to be stopped only need to press **STOP**.

4.9 KEY LOCK Function

4.9.1 KEY LOCK Setting

1. In Power On Menu, you can set KEY LOCK if " LOCK" is not highlighted.
2. Press Function Key [MENU], the menu shown below.

1. MEMORY					UP
2. SYSTEM					DOWN
3. OPTION					SELECT
4. CALIBRATION					
5. KEY LOCK					
SELECT FUNC.	RMT	LOCK	OFST	ERR	EXIT

- Use Function Key [UP] and [DOWN] to move the highlight to “KEY LOCK”, and press Function Key [SELECT] to enter KEY LOCK setting menu.
- Use Function Key [A] and [B] to input the PASSWORD (default is AAAA.)
- Press [ENTER] will prompt a selection window, and “LOCK” is highlighted. The user can press Function Key [YES] or [NO] to select if lock the MEMORY RECALL function as well.

4.9.2 Canceling KEY LOCK

- In Power On Menu, you can release KEY LOCK if “LOCK” is highlighted.
- Press Function Key [MENU], the menu shown below:

1. MEMORY					UP
2. SYSTEM					DOWN
3. OPTION					SELECT
4. CALIBRATION					
5. KEY LOCK					
SELECT FUNC.	RMT	LOCK	OFST	ERR	EXIT

- Move the highlight to “KEY LOCK” by using Function Key [UP] and [DOWN]. Press Function Key [SELECT] to enter KEY LOCK release menu.
- Use Function Key [A] and [B] to input the PASSWORD (default is AAAA.)
- Press Function Key [ENTER], “LOCK” will not be highlighted means KEY LOCK function has cancelled.

4.10 User Password Setting

1. In Power On Menu, press Function Key [MENU] to show the menu below:

1. MEMORY	UP
2. SYSTEM	DOWN
3. OPTION	SELECT
4. CALIBRATION	
5. KEY LOCK	
SELECT FUNC.	RMT LOCK OFST ERR EXIT

2. Use Function Key [UP] and [DOWN] to move the highlight to "CHANGE PASSWORD" and press Function Key [SELECT] to enter the password menu.
3. Use Function Key [A] and [B] to input the OLD PASSWORD (default is AAAA). After pressing [ENTER], use Function Key [A] and [B] to input NEW PASSWORD (the maximum is 10 characters). After pressing [ENTER], use Function Key [A] and [B] to input CONFIRM PASSWORD (same as NEW PASSWORD) and press Function Key [ENTER]. Press [EXIT] after completing the setting.

4.11 Remote Control

The REMOTE outlet for remote control switch is located at the rear panel. You can plug in the control line to use external signal for controlling the device output externally.

Be aware when using remote control as it is done by external signal and using carefully to avoid the tester error operation to cause any danger. Other control circuit usually does remote control. Be careful that it is the switch to control the mass current output, so you must connect the control line do not get near the power terminal and noise to avoid causing any danger.

1. For single control of START and STOP signals follow *Figure 4-1* listed below to connect them to the REMOTE position on front panel of the main system.

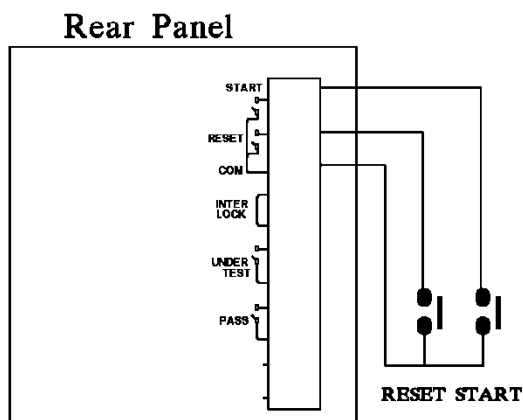

Figure 4-1

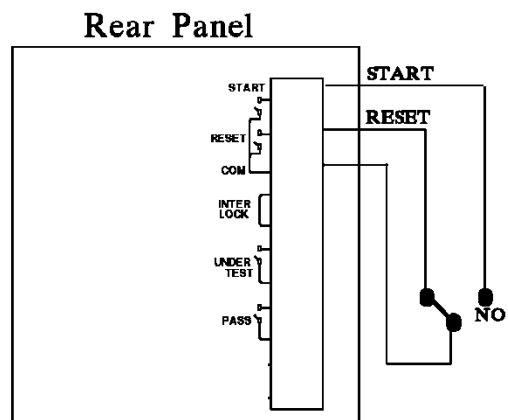

Figure 4-2

2. If it is connected as *Figure 4-2* shows, the system routine is in STOP state as the NC is

connected to STOP and NO is connected to START.

- The logic components of transistor, FET and couplers can be connected and used as control circuit. The connected signals and circuit are shown as *Figure 4-3* below. To use this circuit to control the system, it must contain the following:
 - (1)The current of LOW signal is 2mA or less.
 - (2)The active time for input signal is more than 20mS.

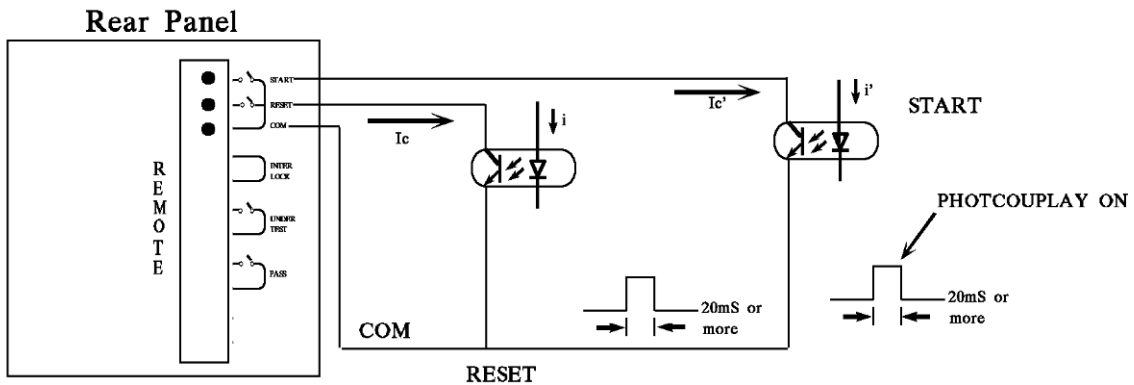

Figure 4-3

- Either the relay switch control in *Figure 4-1* or the coupler control in *Figure 4-3* uses the contact of components for control action. It can prevent the error operation from interference effectively. Though the system has a lot of precautions, it is necessary to be careful the interference caused by the measurement system settings.
- The pin assignment of REMOTE CONTROL is shown as below figure. It should be memorized when using external control.

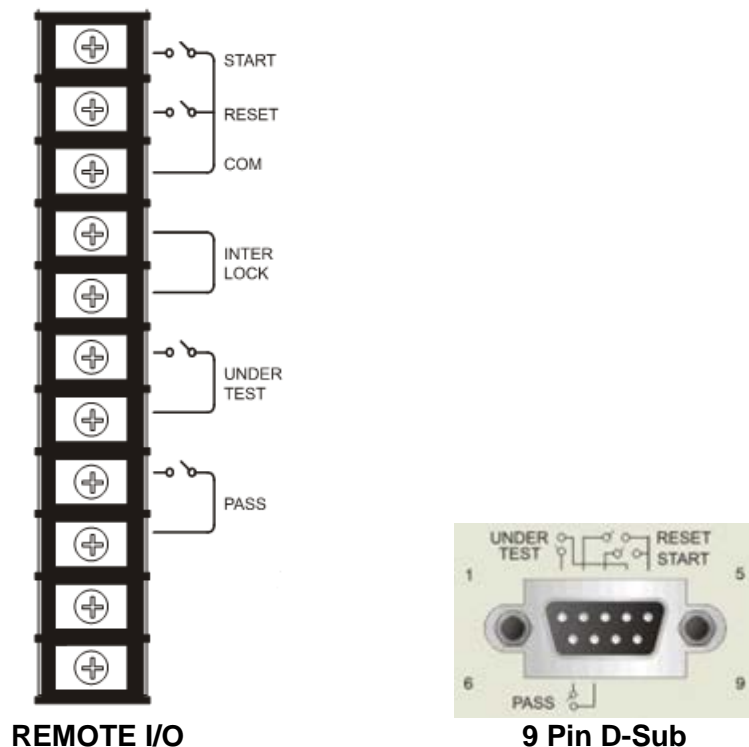

Figure 4-4 Pin assignment printed on the rear panel surface

4.12 Output Signal

This instrument has indicator and beeper for indication signals. The output signals in the system rear panel are:

UNDER TEST: This terminal will be short circuited when in test state, thus it can be used to control the external signal. The connection point specification is 30V AC or 60V DC, the current is less than 0.3A.

PASS: This terminal will be short circuited when the DUT passes the tests, the user specifies the time of short circuit and it can be used to control the external signal. The connection point specification is 30V AC or 60V DC, the current is less than 0.3A. The action time is from the DUT is passed until it is stopped.

4.13 Timing Diagram

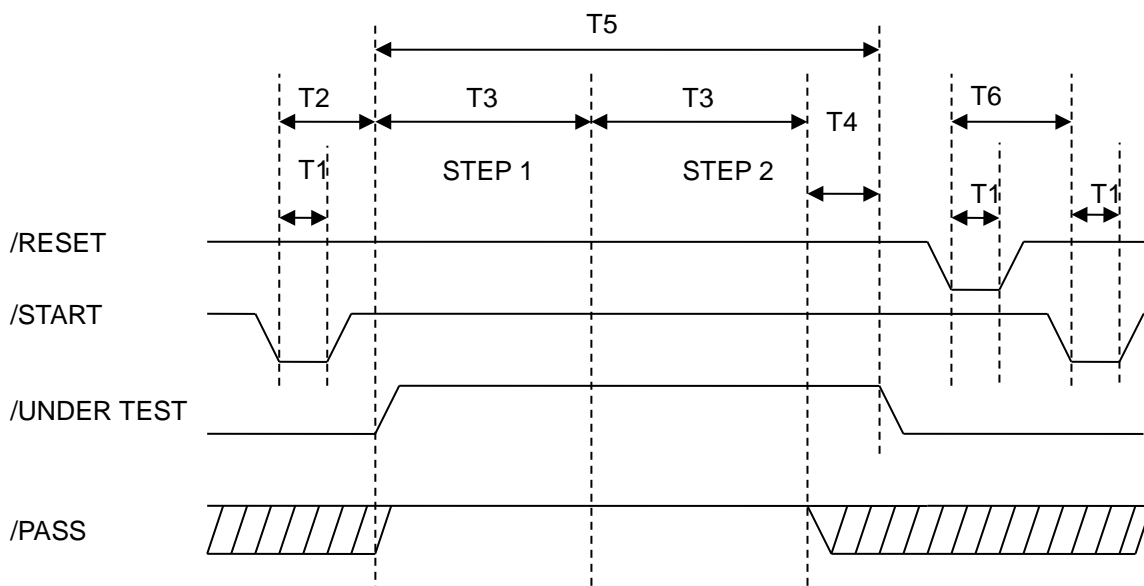

Timing diagram – take an example by two test steps

Time	Limit	Description
T1	> 20mS	The time of external trigger signal /START & /RESET to be remained which needs larger than 20mS.
T2	< 200mS	The time of external trigger signal /START to /UNDER TEST signal to be cleared, it will be smaller than 200mS. The previous STEP test result /PASS signal status has been cleared in advance.
	< 300mS	The time of external trigger signal /START to /UNDER TEST signal to be cleared, it will be smaller than 300mS. The previous STEP test result /PASS signal status hasn't been cleared in advance.
T3	-	Test needed time of various test steps.
T4	> 5mS	/Pass signal sent larger than 5mS, /UNDER TEST signal is end.
T5	-	The equipment used time as testing, the signal is simultaneous with Danger lamp on panel.
T6	>160mS	The time of external trigger signal /RESET to /START signal to be started which needs to be larger than 160mS (SCREEN setting is OFF).
	>250mS	The time of external trigger signal /RESET to /START signal to be started which needs to be larger than 250mS (SCREEN setting is ON).

5. Remote Interface Description

5.1 RS232 Interface Specification

5.1.1 Data Format

Baud Rate: 300 / 600 / 1200 / 2400 / 4800 / 9600 / 19200

Parity: NONE / ODD / EVEN

Flow Control: NONE / SOFTWARE

Transmit bit: 1 initial bit

8 data bit or 7 data bit add 1 parity bit

1 end bit

5.1.2 Command Format

The RS232 interface function of the instrument is inputted by ASCII code to compose command string to remote control and setting function. The length limit of command string is within 1024 characters (include end code) [command + parameter] to compose a command. Two commands can connect by semicolon “;” and add end code finally. End code can be any type of the below. The instrument can distinguish by itself.

End code

LF
CR + LF

5.1.3 Connector

RS232 connector of this tester is a 9-pin female connector.

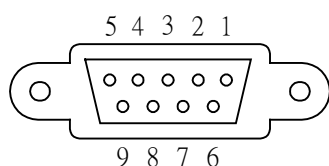

Pin No.	Description
1	* Not used
2	TxD Deliver data
3	RxD Receive data
4	* Not used
5	GND Grounding
6	* Not used
7	* Not used
8	* Not used
9	* Not used

5.1.4 Connection Method

DB-9 to DB-9 Serial Connection

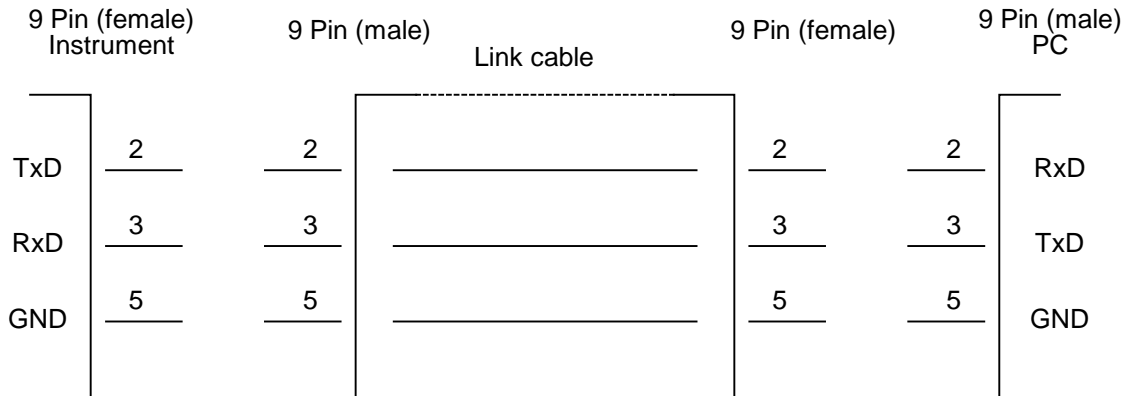

DB-9 to DB-25 Serial Connection

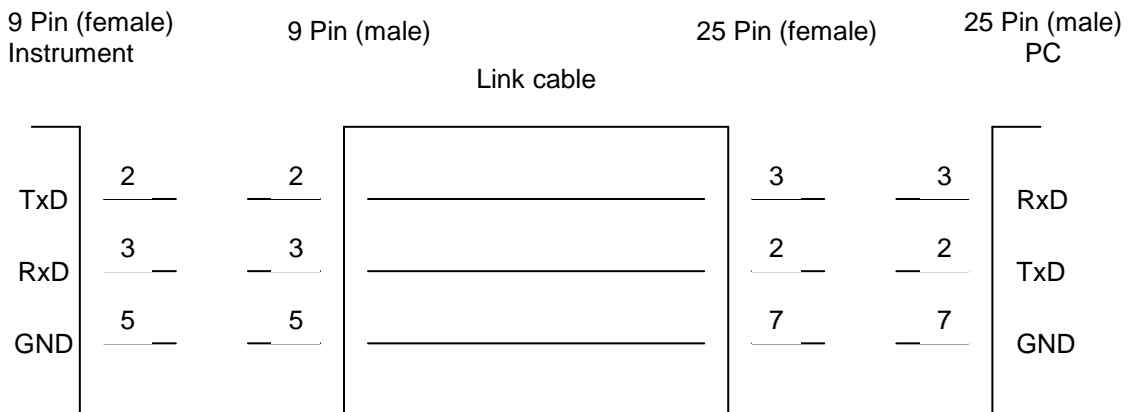

5.2 Remote Interface Command

5.2.1 Command Summary

- **IEEE 488.2 Command**

- *CLS
- *ESE < enable value >
- *ESE?
- *ESR?
- *IDN?
- *OPC
- *OPC?
- *PSC 0 / 1
- *PSC?
- *RST
- *RCL < register number >
- *SAV < register number >
- *SRE < enable value >
- *SRE?

*STB?

The parameter syntax format of SCPI command includes the following.
 Dual arrow symbol "< >" denote the defined parameter of SCPI command standard.
 "< numeric_value >" is metric system value, "<boolean>" is Boolean equation data and
 its' value is 0 or 1. Vertical line "|" denotes OR parameter.

● SCPI Command

```

:MEMory
| :DELeTe
| | :LOCAtion < register number >
| :FRee
| | :STATe?
| | :STEP?
| :STATe

| | :DEFine <name>,<register number>
| | :DEFine? <name>
| | :LABEl? < register number >
| NSTates?
:SYSTem
| :ERRor
| | [NEXT]?
| :VERsion?
| :KLOCK < boolean > / ON / OFF
| :KLOCK?
| :LOCK
| | :OWNer?
| | :REQUest?
| | :RELease
[:SOURce]
:SAFETy
| | :FETCh? [ < item > ] { , < item > }
| | :STARt
| | | [ONCE]
| | | :OFFSet GET | OFF
| | | :OFFSet?
| | :STOP
| | :STATus?
| | :SNUMber?
| | :RESult
| | | :ALL
| | | | [:JUDGment]?
| | | | :OMETerage?
| | | | :MMETerage?
| | | | :MODE?
| | | | :TIME
| | | | | [:ELAPsed]
| | | | | | [:TEST]?
| | | :COMPleted?
| | | [:LAST]
| | | | [:JUDGment]?
| | | | :MMETerage?
| | | | :OMETerage?
| | | :STEP<n>
| | | :JUDGment?

```

			:MMETerage?	
			:OMETerage?	
		:AREPort		
			[:JUDGment]	
			[:MESsage] < boolean > / ON / OFF	(RS232 interface only)
		:AREPort		(RS232 interface only)
			[:JUDGment]	
			[:MESsage] ?	(RS232 interface only)
			:OMETerage < boolean > / ON / OFF	(RS232 interface only)
			:OMETerage?	(RS232 interface only)
			:MMETerage < boolean > / ON / OFF	(RS232 interface only)
			:MMETerage?	(RS232 interface only)
		:ASTart		
			:STATus?	
		:STEP<n>		
			:DELeTe	
			:SEt?	
			:MODE?	
			:GB	
			[:LEVe] < numeric value >	
			[:LEVe]?	
			:LIMit	
			[:HIGH] < numeric value >	
			[:HIGH]?	
			:LOW < numeric value >	
			:LOW?	
			:TIME	
			[:TEST] < numeric value >	
			[:TEST]?	
		:PRESet		
			:TIME	
			:PASS < numeric value >	
			:PASS?	
			:STEP < numeric value > KEY	
			:STEP?	
			:JUDGment < numeric value >	
			:JUDGment?	
		:GB		
			:FREQuency < numeric value >	
			:FREQUery?	
			:VOLTage < numeric value >	
			:VOLTage?	
		:AGC		
			[:SOFTware] <boolean > ON OFF	
			[:SOFTware]?	
		:FCONtinuity		<boolean > ON OFF
		:FCONtinuity?		
		:SCREen		<boolean > ON OFF
		:SCREen?		
		:KEYboard		
			:SMARt <boolean > ON OFF	
			:SMARt?	
		:TIME		
			:ASTart < numeric value >	
			:ASTart?	
		:NUMber		
			:PART <part number>	

				:PART?	
				:LOT	<lot number>
				:LOT?	
				:SERIAL	<serial number>
				:SERIAL?	

5.2.2 Command Description

- **IEEE 488.2 Command**

- ***CLS**

Clear status data configuration the following actions are needed.

Clear standard event status register

Clear status byte register except for MAV bit (bit 4).

- ***ESE < metric system value>**

Use setting standard event status enables register value, <metric system value> range is 0 ~255.

- ***ESE?**

The controller is used for query standard event status of device enable register value.

The output format is <metric system value>, its' range is 0 ~255.

- ***ESR?**

The controller queries the standard event register value of the device. After performing this command, the standard event register value will be cleared to 0.

The output format is <metric system value>, its' range is 0 ~255.

- ***IDN?**

The controller is for reading the basic data of the device. The output format separate four fields by comma, it denote separately: manufacturer, device model, serial number, firmware version.

- ***OPC**

Operation complete command

- ***OPC?**

Operation complete query command

The output format is ASCII character" 1 ".

- ***PSC 0 / 1**

Power on status clear command

- ***PSC?**

Power on status, clears query command. The output format is ASCII character" 1 " or " 0 ".

- ***RST**

The device reset command.

- ***RCL < metric system value>**

Recall command
This command is recall the saved status.

***SAV < metric system value >**
Save command
This command is for saving the current status to the memory.

***SRE < metric system value >**
It is for setting service request register value, its' <metric system value> value is 0 ~ 255.

***SRE?**
The controller is for reading service request enable register initial setting. The output format is <metric system value>, its' range is 0 ~255.

***STB?**
The controller is for reading status bit register value.
The output format is <metric system value>, its' range is 0 ~255

- **SCPI Command**

:MEMory:DELeTe:LOCAtion < register number >
This command is for deleting < register number > denoted parameter data in system memory. < register number > is integral data.

:MEMory:FREE:STATe?
This command is for query remainder PRESET parameter quantity in the system memory.

:MEMory:FREE:STEP?
This command is for querying remainder STEP quantity in the system memory.

:MEMory:STATe:DEFine <name>, <register number >
This command is for defining a name to a memory located at a certain specified position inside the main memory.

:MEMory:STATe:DEFine? <name >
This command is for querying the location inside the main memory by the memory name.

:MEMory:STATe:LABEl? < register number >
This command is for querying the name inside the main memory by the location inside the main memory.

:MEMory:NSTates?
This command is for querying the main system *SAV / *RCL maximum value add 1 of can be used parameter.

:SYSTem:ERRor[:NEXT]?
This command is for reading the message in error queue. Return message, please check error messages in *section 5.3*.

:SYSTem:VERSion?
This command is for querying the system SCPI version.

:SYSTem:KLOCK < boolean > / ON / OFF

This command is for locking or releasing LOCAL key function, but not for switching LOCAL and REMOTE control.

:SYSTem:KLOCK?

This command is for querying if LOCAL key locked or not.

:SYSTem:LOCK:OWNer?

This command is for querying if controlled by REMOTE terminal. Return character NONE|REMOTE.

:SYSTem:LOCK:REQuest?

This command is for switching controlled by REMOTE terminal.

:SYSTem:LOCK:RELease

This command is for switching controlled by LOCAL terminal.

[:SOURce]:SAFEty:FETCh? [< item >] [, < item >]

This command queries the system measurement result, <item> is character data, the meaning as below:

Character Data	Return Data
STEP	The STEP serial number now.
MODE	The MODE now.
OMETerage	The output value now.
MMETerage	The measurement value now.
TELApsed	The TEST executed time now.
TLEFT	The TEST remains time now.

[:SOURce]:SAFEty:STARt[:ONCE]

This command is for starting test.

[:SOURce]:SAFEty:STARt:OFFSet GET / OFF

If the parameter is GET, that is get zero value. At the same time, the system may output mass current. If the parameter is OFF, that is off zero action.

[:SOURce]:SAFEty:STARt:OFFSet?

This command is for querying if does zeroing or not.

[:SOURce]:SAFEty:STOP

This command is for stopping test.

[:SOURce]:SAFEty:STATus?

This command is for querying the current system execution status, return character data RUNNING|STOPPED.

[:SOURce]:SAFEty:SNUMber?

This command is for querying setting STEP number in the memory.

[:SOURce]:SAFEty:RESult:ALL:OMETerage?

This command is for querying OUTPUT METER reading of all steps.

[:SOURce]:SAFEty:RESult:ALL:MMETerage?

This command is for querying MEASURE METER reading of all steps.

[:SOURce]:SAFEty:RESult:ALL:MODE?

This command is for querying MODE of all steps, it will return character data GB.

[:SOURce]:SAFEty:RESult:ALL:TIME[:ELAPsed][:TEST]?

This command is for querying test time of all steps.

[:SOURce]:SAFEty:RESult:ALL[:JUDGment]?

This command is for querying all judgment result. Return format: First Step Result, Second Step Result, ..., Last Step Result. Code meaning as below table:

Test result code table:

Mode Code	GB	
	HEX	DEC
STOP	70	112
USER STOP	71	113
CAN NOT TEST	72	114
TESTING	73	115
PASS	74	116
HIGH FAIL	11	17
LOW FAIL	12	18
OUTPUT A/D OVER	16	22
METER A/D OVER	17	23

[:SOURce]:SAFEty:RESult:COMPLeted?

This command is for querying the system if complete execution action or not, return 1 or 0.

[:SOURce]:SAFEty:RESult[:LAST][:JUDGment]?

This command is for querying judgment result code of last STEP.

The judgment result code table:

Result	Code (hexadecimal)	Code (metric system)
PASS	74	116
USER STOP	71	113
CAN NOT TEST	72	114
TESTING	73	115
STOP	70	112

The judgment result fail code table:

	GB MODE	
	Hex	Dec
HI	11	17
LO	12	18
ADV OVER	16	22
ADI OVER	17	23

[:SOURce]:SAFEty:RESult:LAST:MMETerage?

It queries Measure Meter value of the last step.

[:SOURce]:SAFEty:RESult:LAST:OMETerage?

It queries Output Meter value of the last step.

:SOURce:SAFETy:RESult:STEP<n>:JUDGment?

It queries judgment result code of the selected step.

:SOURce:SAFETy:RESult:STEP<n>:MMETerage?

It queries Measure Meter value of the selected step.

:SOURce:SAFETy:RESult:STEP<n>:OMETerage?

It queries Output Meter value of the selected step.

[[:SOURce]:SAFETy:RESult:AREPort[:JUDGment][:MESSage]< *boolean* > | ON | OFF

This command is for setting if auto report the test result. When set as ON, the test is completed then return "PASS" or "FAIL" string data. (RS232 interface only)

[[:SOURce]:SAFETy:RESult:AREPort[:JUDGment][:MESSage]?

This command is for querying if auto report the test result, return 1 or 0 (RS232 interface only).

[[:SOURce]:SAFETy:RESult:AREPort:OMETerage < *boolean* > | ON | OFF

This command is for setting if auto report the test result. When set as ON, the test is completed then return the output current value of all STEPs. If some STEPs don't be tested, there is without output value. These STEPs return is +9.910000E+37 (RS232 interface only).

[[:SOURce]:SAFETy:RESult:AREPort:OMETerage ?

It queries the output current if auto report the test result, return 1 or 0 (RS232 interface only).

[[:SOURce]:SAFETy:RESult:AREPort:MMETerage < *boolean* > | ON | OFF

It sets the measurement value if auto report the test result. When set as ON, the test is completed then return the measurement value of all STEPs. If some STEPs don't be tested, there is without measurement value. These STEPs return is +9.910000E+37 (RS232 interface only).

[[:SOURce]:SAFETy:RESult:AREPort:MMETerage ?

It queries the measurement value if auto report the test result, return 1 or 0 (RS232 interface only).

[[:SOURce]:SAFETy:AStart:STATus?

This command is for querying GBSS MODE status, return character data ON|OFF.

[[:SOURce]:SAFETy:STEP<n>:DELeTe

This command will delete STEP of <n> represented, the next STEP of <n> will fill it.

[[:SOURce]:SAFETy:STEP<n>:SET?

This command is for querying all setting values in selected STEP.

[[:SOURce]:SAFETy:STEP<n>:MODE?

This command is for querying MODE in selected STEP, it will return character data GB.

[[:SOURce]:SAFETy:STEP<n>:GB[:LEVel] < *numeric value* >

This command is for setting selected STEP, ground resistance test needed current value, the unit is ampere (A).

[[:SOURce]:SAFEty:STEP<n>:GB[:LEVel]?]

This command is for querying selected STEP, ground resistance test needed current value.

[[:SOURce]:SAFEty:STEP<n>:GB:LIMit[:HIGH] < numeric value >]

This command is for setting selected STEP, ground resistance judgment high limit, the unit is Ohm.

[[:SOURce]:SAFEty:STEP<n>:GB:LIMit[:HIGH]?]

This command is for querying selected STEP, ground resistance judgment high limit.

[[:SOURce]:SAFEty:STEP<n>:GB:LIMit:LOW]

This command is for setting selected STEP, ground resistance judgment low limit.

[[:SOURce]:SAFEty:STEP<n>:GB:LIMit:LOW?]

This command is for querying selected STEP, ground resistance judgment low limit.

[[:SOURce]:SAFEty:STEP<n>:GB:TIME[:TEST] < numeric value >]

This command is for setting selected STEP, its' test needed time; the unit is second (s).

[[:SOURce]:SAFEty:STEP<n>:GB:TIME[:TEST]?]

This command is for querying selected STEP, its' test needed time.

[[:SOURce]:SAFEty:PRESet:TIME:PASS < numeric value >]

This command is for setting BUZZER beeps time when passes the test. <numeric_value> is a value between 0.2 and 99.9(included).

[[:SOURce]:SAFEty:PRESet:TIME:PASS?]

This command is for querying BUZZER beeps output continuous time when passes the test. It returns a value between 0.2 and 99.9(included).

[[:SOURce]:SAFEty:PRESet:TIME:STEP < numeric value > / KEY]

This command is for setting interval time between STEP, and the next time to start command to execute the next STEP.

[[:SOURce]:SAFEty:PRESet:TIME:STEP?]

This is for querying interval setting between steps, return value is KEY or the value of unit is second.

[[:SOURce]:SAFEty:PRESet:TIME:JUDGment < numeric value >]

This command is for setting a period of time, a certain of conditions do not detect.

[[:SOURce]:SAFEty:PRESet:TIME:JUDGment?]

This command is for querying the time of waiting detection.

[[:SOURce]:SAFEty:PRESet:GB:FREQuency < numeric value >]

This command is for setting ground impedance test output current frequency.

[[:SOURce]:SAFEty:PRESet:GB:FREQuency?]

This command is for querying ground impedance test output current frequency.

[[:SOURce]:SAFEty:PRESet:GB:VOLTage < numeric value >]

This command is for setting ground impedance test open voltage.

[[:SOURce]:SAFEty:PRESet:GB:VOLTage?

This command is for querying ground impedance test open voltage.

[[:SOURce]:SAFEty:PRESet:AGC[:SOFTware] < boolean > / ON / OFF

This command is for setting software AGC is open or not.

[[:SOURce]:SAFEty:PRESet:AGC[:SOFTware]?

This command is for querying software AGC is open or not. Return character is 1 or 0.

[[:SOURce]:SAFEty:PRESet:FCONtinuity < boolean > / ON / OFF

This command is for setting if continue to test the next step when fails the test.

[[:SOURce]:SAFEty:PRESet:FCONtinuity?

This command is for querying if FCONtinuity is open or not. It returns character 1 or 0.

[[:SOURce]:SAFEty:PRESet:SCREen < boolean > / ON / OFF

This command is for setting the test screen is ON or OFF.

[[:SOURce]:SAFEty:PRESet:SCREen?

This command is for querying the test screen is ON or OFF. It returns character 1 or 0.

[[:SOURce]:SAFEty:PRESet:KEYboard:SMART < boolean > / ON / OFF

This command is for setting SMART KEY is open or not.

[[:SOURce]:SAFEty:PRESet:KEYboard:SMART?

This command is for querying SMART KEY is open or not. It returns character 1 or 0.

[[:SOURce]:SAFEty:PRESet:TIME:ASart < numeric value >

This command is for setting the time of waiting to start of GBSS MODE. The setting range is 0.1~99.9 second. When set to 0, it means GBSS MODE is off.

[[:SOURce]:SAFEty:PRESet:TIME:ASart?

This command is for querying the time of waiting to start of GBSS MODE.

[[:SOURce]:SAFEty:PRESet:NUMber:PART <part number>

This command is for setting part number.

[[:SOURce]:SAFEty:PRESet:NUMber:PART?

This command is for querying part number.

[[:SOURce]:SAFEty:PRESet:NUMber:LOT <lot number>

This command is for setting lot number.

[[:SOURce]:SAFEty:PRESet:NUMber:LOT?

This command is for querying lot number.

[[:SOURce]:SAFEty:PRESet:NUMber:SERial <serial number>

This command is for setting serial number format of product, * means universal character.

[[:SOURce]:SAFEty:PRESet:NUMber:SERial?

This command is for querying serial number format of product.

5.2.3 SCPI Status System

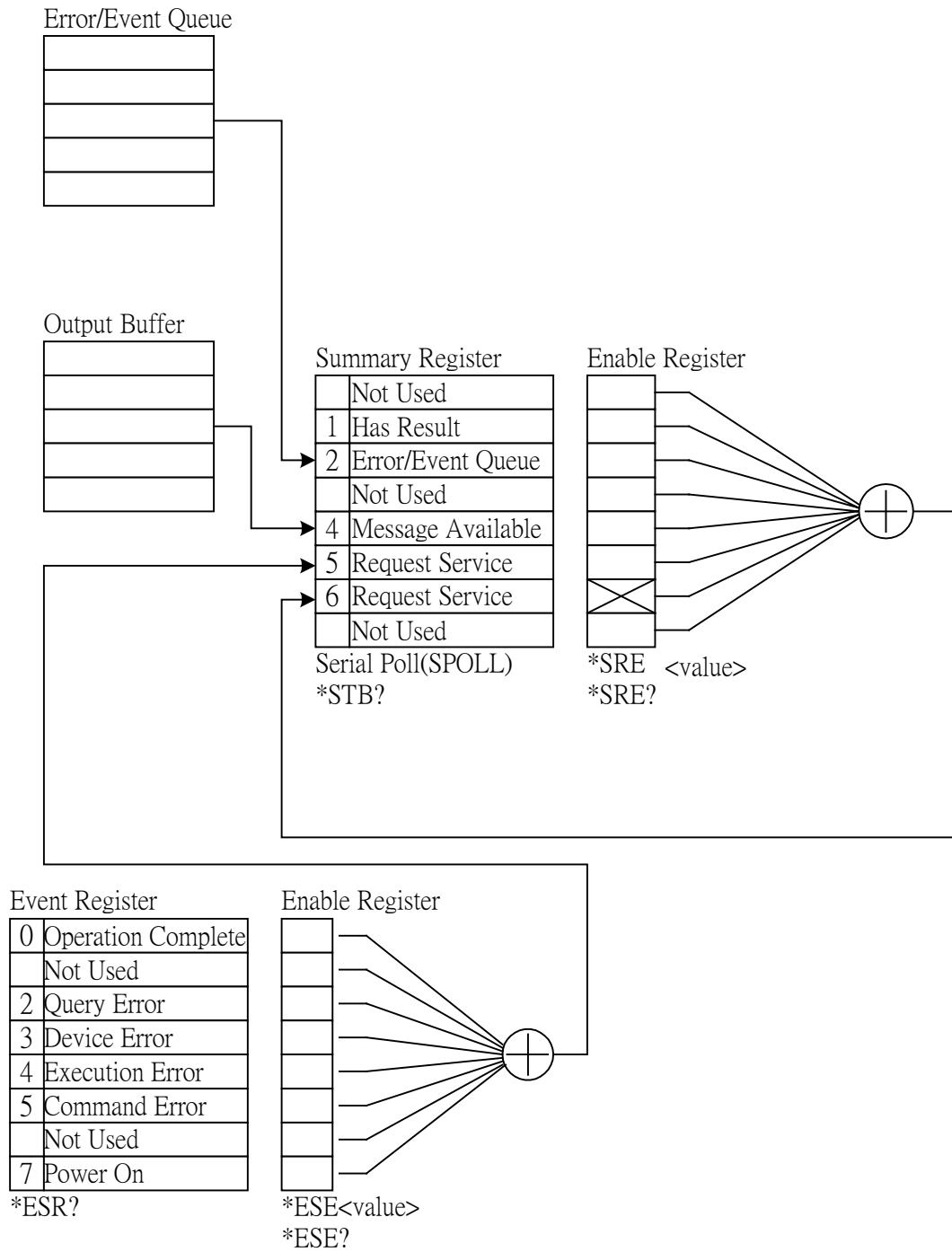

5.3 Error Messages

- Error messages are saved in error queue which access by FIFO method. The return first error message is the first being saved.
- When the error message is over 30, the last position would be saved as -350, "Queue overflow". The error queue can't save error message any more until there is error message out.
- When there is no error occurred, the first position would be saved +0, "No error".

- 102 Syntax error
Syntax error, usually includes not allowed character symbol in command.
- 108 Parameter not allowed
The device receives parameter is not allowed.
- 109 Missing parameter
Parameter is missed.
- 112 Program mnemonic too long
Simple command program header is over 12 characters.
- 113 Undefined header
The device is received undefined header.
- 114 Header suffix out of range
The header suffix is out of range.
- 151 Invalid string data
Invalid string data is usually missing double quotation.
- 158 String data not allowed
The device is received disallowed string data.
- 170 Expression error
The device is received uncompleted parameter data, such as missing the right parenthesis.
- 222 Data out of range
The data is out of range.
- 291 Out of memory
The data is out of memory.
- 361 Parity error
The parity is error.
- 365 Time out error
The device isn't received end character within a certain time.
- 363 Input buffer overrun
The device is received over 1024 characters.
- 400 Queue error
The output queue data is over 256 characters.
- 410 Query INTERRUPTED
When received a query command, you don't read out the query result and then received another query command immediately.
- 420 Query UNTERMINATED
There is no data in queue, meanwhile received the command of reading output queue data.

5.4 RS232 Operation Using Basic

```

REM-----
REM   RS232 example program
REM   Program compiled using Microsoft version 1.1(MS-DOS 6.22)
REM-----

REM open serial port as device 1
OPEN "COM1:9600,N,8,1,RS,CS,DS,CD,LF" FOR RANDOM AS #1
PRINT #1, ":SOURce:SAFEty:STOP"
PRINT #1, ":SOURce:SAFEty:SNUMber ?"
INPUT #1, STEPNUM%
CLS
IF STEPNUM% > 0 THEN
  FOR I = STEPNUM% TO 1 STEP -1
    PRINT #1, "SOURce:SAFEty:STEP", I, ":DELeTe""clear all steps data
  NEXT I
END IF
PRINT #1, "SOURce:SAFEty:STEP1:GB:LEVel 3.1"
PRINT #1, "SOURce:SAFEty:STEP1:GB:LIMit:HIGH 0.2"
PRINT #1, "SOURce:SAFEty:STEP1:GB:TIME:TEST 3.1"
PRINT #1, "SOURce:SAFEty:STEP2:GB:LEVel 3.2"
PRINT #1, "SOURce:SAFEty:STEP2:GB:LIMit:HIGH 0.3"
PRINT #1, "SOURce:SAFEty:STEP2:GB:TIME:TEST 3.2"
SLEEP 1
PRINT #1, "SOURce:SAFEty:STARt"           'start test

PRINT #1, "SOURce:SAFEty:SNUMber?"
INPUT #1, STEPNUM%

WHILE status$ <> "STOPPED"
  PRINT #1, "SOURce:SAFEty:STATUS?"
  INPUT #1, status$      'read status

  IF status$ = "STOPPED" THEN           'if status not=TEST
    PRINT #1, "SOURce:SAFEty:STOP"

    PRINT #1, "SAFEty:RESult:ALL:OMET?"
    FOR j = 1 TO STEPNUM%
      INPUT #1, result$
      PRINT "step", j, ":", result$
    NEXT j
    PRINT
    PRINT #1, "SAFEty:RESult:ALL:MMET?"
    FOR j = 1 TO STEPNUM%
      INPUT #1, result$
      PRINT "step", j, ":", result$
    NEXT j
  END IF
WEND
PRINT #1, "SOURce:SAFEty:STOP"
CLOSE #1
END

```

6. GPIB Description (Option)

6.1 Guide

The user can use computer by GPIB (IEEE 488-1978) interface to remote control and data transfer.

6.2 Interface Specification

6.2.1 Applicable Standard

IEEE488-1978 standard

6.2.2 Interface Capability

Code	Meaning
SH1	Source Handshake Equipped with source handshake interface function.
AH1	Acceptor Handshake Equipped with acceptor handshake interface function.
T4	Basic Talker requirement Equipped with basic talker interface function.
L4	Basic Listener requirement Equipped with basic listener interface function.
SR1	Service request requirement Equipped with service request interface function.
RL1	All remote/local requirement Equipped with remote/local interface function.
PP0	No Parallel poll requirement No parallel poll interface function.
DC1	All device clear requirement Equipped with device clear interface function.
DT0	No Device trigger requirement No device trigger interface function.
C0	No controller requirement No controller interface function.

6.2.3 Using Code

ASCII code.

6.3 GPIB Related Panel Description

6.3.1 Address Setting

- Under power on menu, press Function Key **MENU** as the following shown:

1. MEMORY	UP
2. SYSTEM	DOWN
3. OPTION	SELECT
4. CALIBRATION	EXIT
5. KEY LOCK	
SELECT FUNC.	RMT LOCK OFST ERR

- Move the highlight to "OPTION" by Function Key **UP**, **DOWN**. Press Function Key **SELECT** to enter OPTION selection setting as the following shown:

1.RS232	UP
2. GPIB	DOWN
3.PRINTER	SELECT
	EXIT
	RMT LOCK OFST ERR

- Move the highlight to "GPIB" by Function Key **UP**, **DOWN**. Press Function Key **SELECT** to enter GPIB setting menu as the following shown:

1.GPIB ADDR.: 3	UP
	DOWN
	ENTER
	EXIT
	RMT LOCK OFST ERR

- Then select GPIB Address by Function Keys **UP**, **DOWN**.
- The setting is completed, presses Function Key **EXIT** to exit.

6.3.2 Remote / Local

- The signal block Remote is highlighted, it means the tester is on Remote status.
- On Remote status can use Function Key **LOCAL** to switch the tester to Local status.

3. On Remote status, all of panel keys are malfunction except for Function Key **LOCAL** (switch to Local) **MENU**, **MORE..** and **STOP** (reset instrument) keys.
4. By using LLO [Local lockout] command of GPIB makes **LOCAL** key malfunction.

6.4 Interface Message

The tester is capable of responding to the following interface messages.

Interface Signal	Meaning	Response
GTL	Go To Local	Can switch the tester to Local status.
SDC	Selected Device Clear	Restart the analyzer
LLO	Local Lockout	From LOCAL key switch to Local status is forbidden.
IFC	Interface Clear	Reset GPIB interface.

6.5 GPIB Control / Setting Command Descriptions

The tester GPIB function composed command string is inputted by ASCII code to attain functions of remote control and setting. The length of the command string is limited in 1024 characters (include end code) [Command + Parameter] compose a command. Two commands can be connected by semicolon and ended by end code. The end code can be any type of the following; the tester can distinguish by itself.

End code

LF
CR + LF
EOI
LF + EOI
CR + LF + EOI

Status response command

```
*CLS
*ESE <enable value>
*ESE?
*ESR?
*SRE <enable value>
*SRE?
*STB?
*PSC 0|1
*PSC?
```

7. Printer Function (Option)

Preface

The user can connect printer (any brand printer except for HP) to print test parameter setting value or test result report.

How to print test parameter setting value?

1. Under power-on screen, press Function Key F3 **MENU** then move the cursor to 8. PRINT PROGRAM.
2. Press Function Key F3 **SELECT**, connect the correct printer then will auto print out the test parameter setting value in the memory.

How to print test result report?

After setting printer print parameter, follows normal test procedures to test. When test is completed according to the user setting, connect the correct printer to print out test result report.

Enter printer print parameter setting screen.

1. Under power-on screen, press Function Key **MENU** then move the cursor to 3. OPTION.
2. Press Function Key **SELECT**, then move the cursor to 3. PRINT.
3. Press Function Key F3 **SELECT**, then start to set print parameter.

How to set printer print parameter?

1. By using Function Keys **UP**, **DOWN** to set various parameter data.
2. By using Function Key **ENTER** to move the cursor.
3. By using Function Key **EXIT** to exit this screen.

Print parameter description:

- A. AUTO PRINT - - includes the following two parameters for setting print test result report timing.
1. PASS: OFF - - When setting is ON, the test result is PASS will print out the test result report.
 2. FAIL: OFF - - When setting is ON, the test result is FAIL will print out the test result report.
 3. F .FEED: OFF - - When setting is ON, end the print and printing paper will skip to another page.
- B. PRINT DATA - - Includes the following five parameters for setting print test result report that includes data.
1. PART NO.: OFF -- When setting is ON, the test result report will print PART NUMBER.
 2. LOT NO.: OFF -- When setting is ON, the test result report will print LOT NUMBER.
 3. SERIAL NO.: OFF -- When setting is ON, the test result report will print SERIAL NUMBER.
 4. TEST DATA: OFF -- When setting is ON, the test result report will print STEP, MODE and current/resistance data.
 5. RESULT: OFF -- When setting is ON, the test result report will print the test result is PASS or FAIL.

8. Calibration Procedure

Calibration equipment:

1. Standard resistance 10m/100m/150m/500m Ω
2. Agilent 34401A Digital Multimeter or above
3. Yokogawa TYPE 2215 50A Current Shunt or above

Before process this section the tester should be warm up at least 30 minutes. Press the calibration switch (CAL), it is equipped with hardware protection circuit to avoid calibration data loss.

The following items are needed to calibrate:

GBA	45A	Offset (3A)	;GB current	OFFSET	point
GBA	45A	Full (30A)	;GB current	FULL	point
GBVX1	8V	Offset (0.3V)	;GB voltage X1	OFFSET	point
GBVX1	8V	Full (3V)	;GB voltage X1	FULL	point
GBVX10	8V	Offset (0.03V)	;GB voltage X10	OFFSET	point
GBVX10	8V	Full (0.3V)	;GB voltage X10	FULL	point
CONTRAST	VALUE	6	;Contrast Value		

8.1 Calibration Menu

1. After powered on and initialized, press function key [MENU] [DOWN] [DOWN] [DOWN] [SELECT] in sequence to enter CALIBRATION function. Display input calibration password menu.
2. Press function key [A] [A] [A] [B] [SELECT] in sequence. Display calibration menu.

8.2 Start Calibration

Connect Yokogawa TYPE 2215 Current Shunt (50 mV, 50A, with four terminals) or equivalent shunt to Sense and Drive terminal of 19572. By using 34401A DMM to set ACV Meter and Auto Range function simultaneously, measure TYPE 2215 Current Shunt SENSE +/- terminals.

Display	GBA 45A OFFSET (3A) 3.00A	; Grounding current offset.
Press	[STOP] [START]	; Read out the ACV meter value ; Example 2.897mV
Press	[INC.] or [DEC.] until 19572 LCD STANDARD display 2.897 A	
Press	[ENTER]	; Save calibration value into the memory
Press	[STOP]	; Stop GBA offset calibration.
Press	[UP] key to display	
Display	GBA 45A FULL (30A) 30.00A	; Grounding current full scale.
Press	[STOP] [START]	; Read out the ACV meter value ; Example 29.87mV

Press [INC.] or [DEC.] until 19572 LCD STANDARD display 29.87 A
Press [ENTER] ; Save calibration value into the memory
Press [STOP] ; Stop GBA full scale calibration.

Take off Current Shunt, connect the test cable of main system to 100mΩ STANDARD.
Connect AC voltage meter to 19572 Sense + and Sense – terminals.

Press [UP] key to display ; Grounding voltage offset.
Display GBVX1 8V OFFSET(0.3V) ; 3.0Amp into 100mΩ
0.300V
Press [STOP] [START] ; Read out the ACV meter value
; Example 0.302 volts
Press [INC.] or [DEC.] until 19572 LCD STANDARD display 0.302V
Press [ENTER] ; Save calibration value into the memory.
Press [STOP] ; Stop GBV offset calibration.
Press [UP] key to display ; Grounding voltage full scale.
Display GBVX1 8V FULL (3V) ; 30Amp into 100mΩ.
3.000V
Press [STOP] [START] ; Read out the ACV meter value
; Example 3.021 volts
Press [INC.] or [DEC.] until 19572 LCD STANDARD display 3.021 V
Press [ENTER] ; Save calibration value into the memory.
Press [STOP] ; Stop GBV full scale calibration.
Press [UP] to display ; Grounding voltage offset
Display GBVX10 8V OFFSET(0.03V) ; 0.3Amp into 100mΩ
0.030V
Press [STOP] [START] ; Read out the ACV meter value
; Example 0.031 volts
Press [INC.] or [DEC.] until 19572 LCD STANDARD display 0.031V.
Press [ENTER] ; Save calibration value into the memory.
Press [STOP] ; Stop GBV full scale calibration.
Press [UP] to display ; Grounding voltage full scale.
Display GBVX10 8V FULL (0.3V) ; 3Amp into 100mΩ.
0.300V
Press [STOP] [START] ; Read out the ACV meter value
; Example 0.302 volts
Press [INC.] or [DEC.] until 19572 STANDARD display 0.302 V
Press [ENTER] ; Save calibration value into the memory.
Press [STOP] ; Stop GBV full scale calibration.
Press [UP] key to display ; Contrast adjust value
Press [SETUP] key to display contrast value 6
Press [INC.] or [DEC.] until LCD brightness is applicable.
Press [ENTER] [EXIT] key to quit calibration process

8.3 Complete Calibration

Press (CAL) switch off on front panel to avoid data loss.

Press [DOWN] [DOWN] [DOWN] [SELECT]
Display PASSWORD:
Press [A] [A] [A] [A] [ENTER]

Display The Calibration is ON.

If display "The Calibration is OFF". Then press [A] [A] [A] [A] [ENTER] again until display "The Calibration is ON".

9. INTERLOCK OPEN, Various Status

Definition of Tester

9.1 Before Testing

Before testing, INTERLOCK OPEN, whatever the tester set any data, press START key in the meantime, then the left down side of LCD shows CAN NOT TEST. By using RS232 or GPIB interface, give **[:SOURCE]:SAFETY:RESUlt[:LAST][:JUDGment]?** command to query the judgment result, return code is 114.

9.2 Under Test

Under test (voltage output and STEP HOLD TIME \neq key are included), INTERLOCK OPEN, the tester stops the test immediately. This is equal to press STOP key, the left down side of LCD shows STOPPED.

1. INTERLOCK still OPEN, if press START key this time, all STEP states are initialized and stays on STEP1 screen then the left down side of LCD shows CAN NOT TEST. By using RS232 or GPIB interface, give **[:SOURCE]:SAFETY:RESUlt[:LAST][:JUDGment]?** command to query the judgment result, return code is 114.
2. When INTERLOCK CLOSE if press START key then the test is from STEP1.

9.3 STEP HOLD TIME \neq KEY, FAIL CONT. = OFF

1. After all steps are tested, LCD shows PASS. When INTERLOCK OPEN, if press START key, all STEP states are initialized and on STEP1 screen then the left down side of LCD shows CAN NOT TEST. By using RS232 or GPIB interface, give **[:SOURCE]:SAFETY:RESUlt[:LAST][:JUDGment]?** command to query the judgment result, return code is 114.
2. If FAIL occurred in a certain of STEP, INTERLOCK OPEN at this time. START key is invalid and keeps the original FAIL status.

9.4 STEP HOLD TIME = KEY, FAIL CONT. = OFF

1. After all steps are tested, LCD shows PASS. Please refer item 1 in *section 9.3*.
2. If don't test all steps and WAIT KEY, INTERLOCK OPEN at this time. Press START key then the next step status becomes CAN NOT TEST. By using RS232 or GPIB interface, give **[:SOURCE]:SAFETY:RESUlt[:LAST][:JUDGment]?** command to query the judgment result, return code is 114. When INTERLOCK CLOSE, press START key then will be tested from pretest step.
3. If FAIL occurred in a certain of STEP, INTERLOCK OPEN at this time. START key is invalid and keeps the original FAIL status.

9.5 STEP HOLD TIME \neq KEY, FAIL CONT. = ON

1. After all steps are tested, LCD shows PASS. Please refer item 1 in *section 9.3*.
2. After all steps are tested, LCD shows FAIL. Please refer item 2 in *section 9.3*.
3. If FAIL occurred in a certain of STEP and under test. Please refer item 1 in *section 9.2*.

9.6 STEP HOLD TIME = KEY, FAIL CONT. = ON

1. After all steps are tested, whatever LCD shows PASS or FAIL, INTERLOCK OPEN at this time. If START key was pressed, all STEP states are initialized and stays on STEP1 screen then the left down side of LCD shows CAN NOT TEST. By using RS232 or GPIB interface, give `[:SOURce]: SAFETy:RESult[:LAST][:JUDGment]?` command to query the judgment result, return code is 114.
2. When WAIT KEY, please refer item 2 in *section 9.4*.

10. GBSS MODE

GBSS MODE, *i.e.* Ground Bond Smart Start Mode.

Main Function:

When the test terminal contacts DUT, the tester will be activated automatically to test DUT. It is no need to start the instrument by pressing START key.

Operation Method:

1. Press function key [PROGRAM] under main screen. After entering this screen, set various parameter values of preset and back to main screen when completed.
2. Press function key [PRESET] under main screen. After entering this screen, select 10.START WAIT and then to set needed wait time for starting (wait time, *i.e.* the time of the test terminal connects DUT to start the tester).
3. Press function key [EXIT] to return to main screen. Press START key to activate GBSS MODE then the left down side of LCD shows "GB OPEN..". It denotes the test terminal do not contact DUT. (Note 1)
4. After DUT contacted, then to start counting and wait to activate. When the counting is completed then to start test.
5. When the test is completed, the test terminal and DUT disconnected and then connects the next DUT for testing.
6. Press STOP key then can stop GBSS MODE. (Note 2)
7. Enter [PRESET] to set 10.START WAIT to OFF and then close GBSS MODE. (Note 3).

Note

1. When start GBSS MODE, all of keys are malfunction except for STOP and INTERLOCK. Press STOP key to stop GBSS MODE if the user want to recover other keys' function.
2. Press STOP key, just stop GBSS MODE. As the user press START, it will enter GBSS MODE again.
3. When set 10.START WAIT to OFF in [PRESET] menu, the tester will become the normal test mode (need to press START key to start test).

11. Maintenance

11.1 General

Our warranty (at the front of the manual) attests the quality of materials and workmanship in our products. If malfunction should be suspected, or other information be desired applications engineers are available for technical assistance. Application assistance is available in Taiwan by calling 886-3-3279999 and asking for applications support. For supporting outside of Taiwan please contact your local Chroma distributor.

11.2 Cleaning

If there is any dirt on the cover of the tester, use the general for cleaning alcohol to wipe, and power on until LCD is dried.

11.3 Battery Replacement

Batteries are included in the tester. Please contact the service center for battery replacement.

 **CAUTION** ⚠ Do not open the cover of the device for battery replacement by yourself.

Battery specification

1. Model: CR2/38.L
2. Nominal voltage: 3V
3. Typical capacity: 1800mAH (Rated capacity at 200uA to 20°C)
(End-point voltage: 2.0V)

11.4 Instrument Return

Before returning an instrument to Chroma for service please call our Service Department at 886-3-3279688 for return material authorization. It is necessary to include a purchase order number to ensure expedient processing. The units found to be in warranty will be repaired at no-charge. For any questions on repair costs or shipment instructions please contact our service department at the above number. To safeguard an instrument during storage and shipping please use packaging that is adequate to protect it from damage, *i.e.*, equivalent to the original packaging and mark the box "Delicate Electronic Instrument". Return material should be sent freight prepaid, to:

Chroma Ate Inc.
66 Huaya 1st Road, Guishan,
Taoyuan 33383, Taiwan
Attention: Service Department

 **CAUTION** ⚠ The tester is overweight, please use handcart to avoid injuring.

Chroma's Continuous Quality Process User Manual Customer Feedback

Chroma welcomes all comments and recommendations to improve this publication in the future editions. Please scan the QR code below or click the URL <http://www.chromaate.com/survey?n=793ce6db-17ef-4cd3-b0de-8bbd09aa38e0> to fill in the customer feedback form. Thank you!





CHROMA ATE INC.

致茂電子股份有限公司

66 Huaya 1st Road,

Guishan, Taoyuan 33383, Taiwan

台灣桃園市 33383 龜山區

華亞一路 66 號

T +886-3-327-9999

F +886-3-327-8898

Mail: info@chromaate.com

<http://www.chromaate.com>