

**Chroma**

**HIPOT Tester**  
**19071/19072/19073**  
**User's Manual**

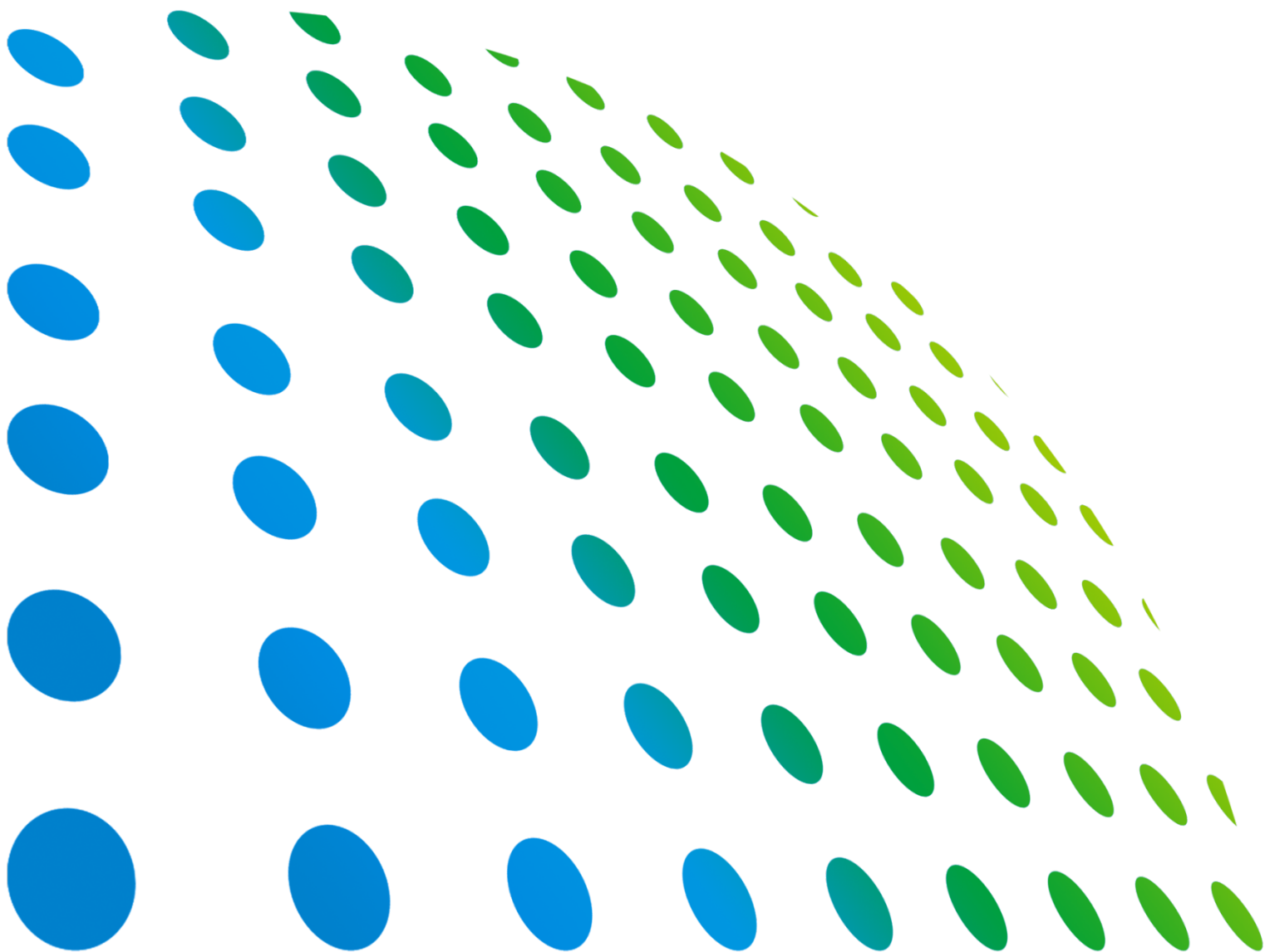



# HIPOT Tester 19071/19072/19073 User's Manual



Version 3.2  
April 2017

# Legal Notices

The information in this document is subject to change without notice.

Chroma ATE INC. makes no warranty of any kind with regard to this manual, including, but not limited to, the implied warranties of merchantability and fitness for a particular purpose. Chroma ATE INC. shall not be held liable for errors contained herein or direct, indirect, special, incidental or consequential damages in connection with the furnishing, performance, or use of this material.

## **CHROMA ATE INC.**

66 Huaya 1st Road, Guishan, Taoyuan 33383, Taiwan

Copyright Notices. Copyright 2003 - 2017 Chroma ATE INC., all rights reserved. Reproduction, adaptation, or translation of this document without prior written permission is prohibited, except as allowed under the copyright laws.

# Warranty

All of Chroma's instruments are warranted against defects in material and workmanship for a period of one year from date of shipment. Chroma agrees to repair or replace any assembly or component found to be defective, under normal use during this period. Chroma's obligation under this warranty is limited solely to repairing any such instrument, which in Chroma's sole opinion proves to be defective within the scope of the warranty when returned to the factory or to an authorized service center. Purchaser is responsible for the shipping and cost of the service item to Chroma factory or service center. Shipment should not be made without prior authorization by Chroma.

This warranty does not apply to any products repaired or altered by persons not authorized by Chroma, or not in accordance with instructions furnished by Chroma. If the instrument is defective as a result of misuse, improper repair, or abnormal conditions or operations, repairs will be billed at cost.

Chroma assumes no responsibility for its product being used in a hazardous or dangerous manner either alone or in conjunction with other equipment. High voltage used in some instruments may be dangerous if misused. Special disclaimers apply to these instruments. Chroma assumes no liability for secondary charges or consequential damages and in any event, Chroma's liability for breach of warranty under any contract or otherwise, shall not exceed the purchase price of the specific instrument shipped and against which a claim is made.

Any recommendations made by Chroma regarding the use of its products are based upon tests believed to be reliable; Chroma makes no warranty of the results to be obtained. This warranty is in lieu of all other warranties, expressed or implied, and no representative or person is authorized to represent or assume for Chroma any liability in connection with the sale of our products other than set forth herein.

## **CHROMA ATE INC.**

66 Huaya 1st Road, Guishan,  
Taoyuan 33383, Taiwan  
Tel: 886-3-327-9999  
Fax: 886-3-327-2886  
e-mail: [info@chromaate.com](mailto:info@chromaate.com)  
<http://www.chromaate.com>

# Material Contents Declaration

The recycling label shown on the product indicates the Hazardous Substances contained in the product as the table listed below.

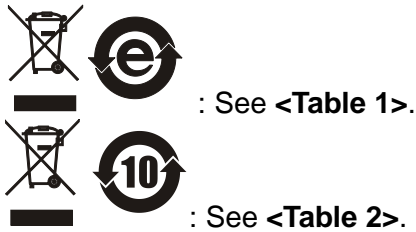

<Table 1>

Part Name	Hazardous Substances					
	Lead	Mercury	Cadmium	Hexavalent Chromium	Polybrominated Biphenyls/ Polybromodiphenyl Ethers	Selected Phthalates Group
	Pb	Hg	Cd	Cr <sup>6+</sup>	PBB/PBDE	DEHP/BBP/DBP/DIBP
PCBA	O	O	O	O	O	O
CHASSIS	O	O	O	O	O	O
ACCESSORY	O	O	O	O	O	O
PACKAGE	O	O	O	O	O	O

“O” indicates that the level of the specified chemical substance is less than the threshold level specified in the standards of SJ/T-11363-2006 and EU Directive 2011/65/EU.

“X” indicates that the level of the specified chemical substance exceeds the threshold level specified in the standards of SJ/T-11363-2006 and EU Directive 2011/65/EU.

Remarks: The CE marking on product is a declaration of product compliance with EU Directive 2011/65/EU.

## Disposal

Do not dispose of electrical appliances as unsorted municipal waste, use separate collection facilities. Contact your local government for information regarding the collection systems available. If electrical appliances are disposed of in landfills or dumps, hazardous substances can leak into the groundwater and get into the food chain, damaging your health and well-being. When replacing old appliances with new one, the retailer is legally obligated to take back your old appliances for disposal at least for free of charge.



<Table 2>

Part Name	Hazardous Substances					
	Lead	Mercury	Cadmium	Hexavalent Chromium	Polybrominated Biphenyls/ Polybromodiphenyl Ethers	Selected Phthalates Group
	Pb	Hg	Cd	Cr <sup>6+</sup>	PBB/PBDE	DEHP/BBP/DBP/DIBP
PCBA	×	○	○	○	○	○
CHASSIS	×	○	○	○	○	○
ACCESSORY	×	○	○	○	○	○
PACKAGE	○	○	○	○	○	○

“○” indicates that the level of the specified chemical substance is less than the threshold level specified in the standards of SJ/T-11363-2006 and EU Directive 2011/65/EU..

“×” indicates that the level of the specified chemical substance exceeds the threshold level specified in the standards of SJ/T-11363-2006 and EU Directive 2011/65/EU..

1. Chroma is not fully transitioned to lead-free solder assembly at this moment; however, most of the components used are RoHS compliant.
2. The environment-friendly usage period of the product is assumed under the operating environment specified in each product's specification.

### Disposal

Do not dispose of electrical appliances as unsorted municipal waste, use separate collection facilities. Contact your local government for information regarding the collection systems available. If electrical appliances are disposed of in landfills or dumps, hazardous substances can leak into the groundwater and get into the food chain, damaging your health and well-being. When replacing old appliances with new one, the retailer is legally obligated to take back your old appliances for disposal at least for free of charge.





# Declaration of Conformity

For the following equipment :

**AC/DC/IR Hipot Tester**

(Product Name/ Trade Name)

**19071, 19073**

(Model Designation)

**CHROMA ATE INC.**

(Manufacturer Name)

**66 Huaya 1<sup>st</sup> Road, Guishan, Taoyuan 33383, Taiwan**

(Manufacturer Address)

Is herewith confirmed to comply with the requirements set out in the Council Directive on the Approximation of the Laws of the Member States relating to Electromagnetic Compatibility (2014/30/EU) and Low Voltage Directive (2014/35/EU). For the evaluation regarding the Directives, the following standards were applied :

**EN 61326-1:2013, Table 2, CISPR 11:2009+A1:2010, Group 1 Class A**

**EN 61000-3-2:2006+A1:2009+A2:2009, Class A, EN 61000-3-3:2013**

IEC 61000-4-2:2008, IEC 61000-4-3:2006+A1:2007+A2:2010, IEC 61000-4-4:2012,

IEC 61000-4-5:2005, IEC 61000-4-6:2008, IEC 61000-4-8:2009, IEC 61000-4-11:2004

**IEC 61010-1:2010, EN 61010-1:2010**

**IEC 61010-031:2002+A1, EN 61010-031:2002+A1**

**IEC 61010-2-030:2010, EN 61010-2-030:2010**

The equipment describe above is in conformity with Directive 2011/65/EU of the European Parliament and of the Council of 8 June 2011 on the restriction of the use of certain hazardous substances in electrical and electronic equipment.

The following importer/manufacturer or authorized representative established within the EUT is responsible for this declaration :

**CHROMA ATE INC.**

(Company Name)

**66 Huaya 1<sup>st</sup> Road, Guishan, Taoyuan 33383, Taiwan**

(Company Address)

Person responsible for this declaration:

**Mr. Vincent Wu**

(Name, Surname)

**T&M BU Vice President**

(Position/Title)

**Taiwan**

(Place)

**2017.02.21**

(Date)

(Legal Signature)

# Safety Summary

The following general safety precautions must be observed during all phases of operation, service, and repair of this instrument. Failure to comply with these precautions or specific WARNINGS given elsewhere in this manual will violate safety standards of design, manufacture, and intended use of the instrument. *Chroma* assumes no liability for the customer's failure to comply with these requirements.



## BEFORE APPLYING POWER

Verify that the power is set to match the rated input of this power supply.



## PROTECTIVE GROUNDING

Make sure to connect the protective grounding to prevent an electric shock before turning on the power.



## NECESSITY OF PROTECTIVE GROUNDING

Never cut off the internal or external protective grounding wire, or disconnect the wiring of protective grounding terminal. Doing so will cause a potential shock hazard that may bring injury to a person.



## FUSES

Only fuses with the required rated current, voltage, and specified type (normal blow, time delay, etc.) should be used. Do not use repaired fuses or short-circuited fuse holders. To do so could cause a shock or fire hazard.



## DO NOT OPERATE IN AN EXPLOSIVE ATMOSPHERE













Do not operate the instrument in the presence of flammable gases or fumes. The instrument should be used in an environment of good ventilation.



## DO NOT REMOVE THE COVER OF THE INSTRUMENT

Operating personnel must not remove the cover of the instrument. Component replacement and internal adjustment can be done only by qualified service personnel.

# Safety Symbols

	<b>DANGER</b> – High voltage.
	<b>Explanation:</b> To avoid injury, death of personnel, or damage to the instrument, the operator must refer to the explanation in the instruction manual.
	<b>High temperature:</b> This symbol indicates the temperature is hazardous to human beings. Do not touch it to avoid any personal injury.
	<b>Protective grounding terminal:</b> This symbol indicates that the terminal must be connected to ground before operation of the equipment to protect against electrical shock in case of a fault.
	<b>Functional grounding:</b> To identify an earth (ground) terminal in cases where the protective ground is not explicitly stated. This symbol indicates the power connector does not provide grounding.
	<b>Frame or chassis:</b> To identify a frame or chassis terminal.
	<b>Alternating Current (AC)</b>
	<b>Direct Current (DC) / Alternating Current (AC)</b>
	<b>Direct Current (DC)</b>
	<b>Push-on/Push-off power switch</b>
	The <b>WARNING</b> sign highlights an essential operating or maintenance procedure, practice, condition, statement, etc., which if not strictly observed, could result in injury to, or death of, personnel or long term health hazards.
	The <b>CAUTION</b> sign highlights an essential operating or maintenance procedure, practice, condition, statement, etc., which if not strictly observed, could result in damage to, or destruction of, equipment.
	The <b>Notice</b> sign highlights an essential operating or maintenance procedure, condition, or statement.

# The Danger of Operating

1. When the instrument is under output voltage, please don't touch test area or you may shock hazard and result in death.

Please obey the following items.

- Make sure the grounding cable is connected correctly and using the standard power cord.
  - Don't touch the output terminal.
  - Don't touch test cable of connecting test termination.
  - Don't touch test termination object.
  - Don't touch any charge component of connecting output terminal.
  - As the instrument end the test or turn off output, please don't touch test unit immediately.
2. The shock accidents are usually occurred on the following conditions.
    - The grounding terminal of the instrument doesn't connect correctly.
    - No use insulation glove for testing.
    - After test is completed to touch test unit immediately.
  3. Remote control for the instrument: This instrument provided with remote control, normally using the external signal to control high voltage output. For safety reasons and prevent from hazards, please exactly follow instructions below while using remote control.
    - Unexpected high voltage output may exist. Make sure if this instrument is under testing/remote controlling before access to the probes.
    - When the instrument is under testing/operating, any access to DUT, test cable and probe output terminal are prohibited, both for the operator/service personnel.
    - Normally remote control of this instrument is controlled by the high voltage test bar. However, using of other control circuit is also possible. For safety reasons and prevent from hazards, please notice that unintentional access to the control test bar or bridging the control circuit to high voltage terminal and test cables may cause hazards. Please keep this terminal/control from unintentional bridging/access to avoid danger.

## **WARNING**

1. Don't tie HV cable, RS232, Handler, GPIB control cable and other low voltage cable together. Or it may cause product damaged or PC crashed.
2. To avoid fire, heat and electrical related hazards, before operating always check cable attachment of alligator clipper and connector for both COMMON (RTN/LOW) and OUTPUT (High voltage output) terminals to make sure no conductor strand of test cable is loosen or damaged.

## **DANGER**

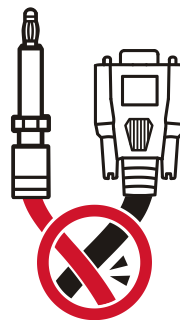

# Storage, Freight, Maintenance & Cleaning

## **Storage**

When not in use, please pack the device properly and store in a suitable environment.

## **Freight**

Please pack the device carefully before moving it. If any of the original packing material is missing, please use suitable alternative material and mark it “fragile” and “keep away from water” to avoid damaging to the product.

This product is a piece of precision test equipment, so please do not drop or hit it.

## **Maintenance**

In case of any malfunction or abnormality, please refer to the manual, or contact our local distributor for prompt service. Do not touch any parts inside the instrument to avoid any danger to yourself or damage to the product.

## **Cleaning**

Remove all connected wires and cables on the instrument before cleaning. Use a brush to clean the dust on it. For internal cleaning, use a low-pressure air gun to vacuum the dust inside or send it back to the distributors or agents of Chroma for cleaning.

# Revision History

The following lists the additions, deletions and modifications in this manual at each revision.

Date	Version	Revised Sections
Jan. 2003	1.0	Complete this manual.
April 2003	1.1	Modify "Specifications (18°C ~ 28°C RH ≤ 70%)" "Standard Accessory" "Rear Panel" "RS-485 Interface" "Solving Problems"
Dec. 2003	1.2	Modify "Introduction" "Rear Panel" "Operation" "Auto Range" "Calibration Procedure" "Command Description"  Delete "RS-485 Interface"  Add "RS485 Interface (Optional)"
March 2004	1.3	Add "The Danger of Operating" "Storage. Freight. Maintenance. Disposal"  Modify "Specifications (18°C ~ 28°C RH ≤ 70%)" "Rear Panel"
Sep. 2004	1.4	Modify "Product Features" "Optional Accessory" "Rear Panel" "PROGRAM Parameter Setting" "How to Perform Tests" "RS485 Interface (Option)"
March 2005	1.5	Modify "Introduction" "System Setup" "PROGRAM Parameter Setting" "How to Perform Tests" "KEY LOCK Function" "Command List" "Command Description"
Aug. 2006	1.6	- Add " <i>CE Statement of Conformity</i> " - Add the description of " <i>Power Cord (W12 030080)</i> " to the section of "Standard Accessory" - Add the section of " <i>Initial Inspection</i> "
Nov. 2006	1.7	- Modify the description of Disposal in " <i>Storage, Freight, Maintenance &amp; Disposal</i> " - Modify the descriptions of RS-485 command in the section of " <i>Command Description</i> ".

March 2007	1.8	Add " <i>Material Contents Declaration</i> " Delete the description of Disposal in " <i>Storage, Freight, Maintenance &amp; Disposal</i> "
Dec. 2007	1.9	Delete the following: - the column of Part Number in the section of " <i>Standard Accessory</i> " & " <i>Optional Accessory</i> ". Modify the following: - the description of "I-RUS" in the section of " <i>PROGRAM Parameter Setting</i> ". - the description of "Inrush" in DC Mode table in the section of " <i>Command Description</i> ".
Dec. 2008	2.0	Modify the following: - the description of "Hipot" item in the section of " <i>Specifications</i> ". - the description of table in the section of " <i>Standard Accessory</i> ". - "(3) System Parameter Setting Table" in the section of " <i>System Setup</i> ". - "PRESET parameter function table" in the section of " <i>PRESET Parameter Setting</i> ". - the menu of "Open/Short Detection Mode (OS)" in the section of " <i>PROGRAM Parameter Setting</i> ". - "Test Steps (OS) Standby Menu" & "Description Table for Test Result" in the section of " <i>How to Perform Tests</i> ". - "CONFIRM Window" in the section of " <i>Change User Password</i> ". - the description in the section of " <i>Command Description</i> ".
Nov. 2009	2.1	Add the descriptions of " <i>RS-232 interface</i> ".
Jun. 2010	2.2	Add two new items in the section of " <i>Solving Problems</i> ".
Dec. 2010	2.3	Modify " <i>Material Contents Declaration</i> ".
Mar. 2011	2.4	Add the section of " <i>Timing Diagram</i> ".
Sep. 2011	2.5	Add the related description of "IR Range Selection".
Mar. 2012	2.6	Modify the following: - " <i>CE Declaration</i> ". - Figure 2-4 in the section of " <i>Remote Control</i> ". - description of "Time T2" in the section of " <i>Timing Diagram</i> ".
Dec. 2012	2.7	Modify the figure of item (2) in the section of " <i>DCA Calibration (DC/IR MODE)</i> ".
Dec. 2013	2.8	Add Standard warnings to the section of " <i>Solving Problems</i> ".
Jan. 2015	2.9	Add the warning to the section of " <i>The Danger of Operating</i> ".
Sep. 2016	3.0	Modify " <i>CE Declaration of Conformity</i> ".
Dec. 2016	3.1	Modify the following: - Rear panel figure in the section of " <i>Rear Panel</i> ".

- Figure 2-1, figure 2-2, figure 2-3 and figure 2-4 in the section of *"Remote Control"*.
- the description of table and timing diagram in the section of *"Timing Diagram"*.

Delete FAIL descriptions in the sections of *"Rear Panel"* and *"Output Signal"*.

Apr. 2017 3.2

Modify the following:

- *"Material Contents Declaration"*.
- *"CE Declaration of Conformity"*.

Add *"User Manual Customer Feedback"*.



# Table of Contents

<b>1.</b>	<b>Introduction.....</b>	<b>1-1</b>
1.1	An Overview of Function .....	1-1
1.2	Product Features .....	1-1
1.3	Specifications (18°C ~ 28°C RH ≤ 70%) .....	1-3
1.4	Standard Accessory .....	1-5
1.5	Optional Accessory .....	1-5
1.6	Initial Inspection .....	1-5
<b>2.</b>	<b>Operation and Setting .....</b>	<b>2-1</b>
2.1	Front Panel .....	2-1
2.1.1	Display Area .....	2-1
2.1.2	Button Area .....	2-2
2.1.3	Terminal Area .....	2-2
2.2	Rear Panel.....	2-3
2.3	Operation .....	2-6
2.3.1	Memory Process .....	2-6
2.3.2	System Setup.....	2-7
2.3.3	PRESET Parameter Setting .....	2-9
2.3.4	PROGRAM Parameter Setting .....	2-9
2.4	How to Perform Tests.....	2-13
2.5	Other User Setting Function.....	2-17
2.5.1	KEY LOCK Function.....	2-17
2.5.2	Auto Range .....	2-17
2.5.3	Change User Password.....	2-18
2.5.4	Remote Control .....	2-19
2.5.5	Output Signal .....	2-20
2.5.6	Timing Diagram .....	2-21
<b>3.</b>	<b>Installation and Maintenance .....</b>	<b>3-1</b>
3.1	Notices for Installation.....	3-1
3.1.1	Charging During DC HiPot/Insulation Resistance Test.....	3-2
3.1.2	Emergency Events .....	3-3
3.1.3	Solving Problems .....	3-3
3.2	Notices for Maintenance .....	3-5
3.3	Troubleshooting .....	3-5
3.4	Input/Output Pin Assignment.....	3-6
<b>4.</b>	<b>Calibration Procedure .....</b>	<b>4-1</b>
4.1	Calibration.....	4-2
4.2	Voltage Calibration.....	4-2
4.2.1	Connection Diagram.....	4-2
4.2.2	ACV Calibration (AC Mode).....	4-2
4.2.3	DCV Calibration (DC/IR MODE) .....	4-3
4.2.4	IRV Calibration (DC/IR Mode).....	4-4
4.3	Current Calibration.....	4-5
4.3.1	Connection Diagram.....	4-5
4.3.2	ACA Calibration (AC MODE) .....	4-5
4.3.3	DCA Calibration (DC/IR MODE) .....	4-6
4.4	ARC Calibration .....	4-8
4.4.1	Connection Diagram.....	4-8
4.4.2	AC ARC Calibration (AC MODE) .....	4-8
4.4.3	DC ARC Calibration (DC MODE).....	4-9

4.5	IRR Calibration (IR Mode).....	4-10
4.5.1	Connection Diagram.....	4-10
4.5.2	Insulation Resistance Calibration.....	4-10
4.6	Ground Continue Calibration.....	4-12
4.6.1	Connection Diagram.....	4-12
4.6.2	Description of Ground Continue Calibration.....	4-12
4.7	LCD Contrast Calibration .....	4-13
4.8	Complete Calibration .....	4-13
<b>5.</b>	<b>RS485 Interface (For Link Model of 19073 + RS485).....</b>	<b>5-1</b>
5.1	Description of Function .....	5-1
5.2	Parameter Setting.....	5-1
5.3	Terminal and Pin Signal Connection.....	5-2
5.4	Communication Protocol .....	5-3
5.5	Command List.....	5-4
5.6	Command Description.....	5-4
5.7	Flow Diagram.....	5-24
<b>6.</b>	<b>RS232 Interface.....</b>	<b>6-1</b>
6.1	Guide .....	6-1
6.2	Interface Specification.....	6-1
6.3	RS-232 Single Unit Connection for Parameter Setting .....	6-1
6.4	Connector .....	6-1
6.5	Method of Connecting.....	6-2
6.6	Communication Protocol .....	6-2
<b>7.</b>	<b>Maintenance.....</b>	<b>7-1</b>
7.1	General.....	7-1
7.2	Instrument Return .....	7-1

# 1. Introduction

## 1.1 An Overview of Function

- This high quality automatic HiPot test instrument is designed to test the withstanding leakage current and insulation resistance for electric machinery and electronic devices.
- For withstanding test, its output power is AC: 100VA (5kV, 20mA), DC: 30VA (6KV, 5mA), which is applicable to electronic, electric machinery and components for withstanding and insulation tests.
- For insulation resistance, its test range is from 0.1M $\Omega$ ~50G $\Omega$ , and test voltage is 0.050kV ~1kV definable.
- For ground continue, its test range is from 0 $\Omega$ ~5 $\Omega$ .
- For short/open detection, before testing high voltage test if the capacitance is short or open circuit in advance. For ensure the DUT is good contact then to perform high voltage test.
- All settings for state, time, current, voltage and resistance can be seen clearly on the display. There is no need to memorize the parameter state of any items.
- It is equipped with devices for Pass/Fail judgment, test results and remote control.
- It can perform high efficiency and accurate tests for electric machinery, electronic devices and components.

## 1.2 Product Features

- **Multiple Test States**  
This instrument can select a single item for test, such as AC withstanding test, DC withstanding test, insulation resistance test, ground continue test and short/open detection test.
- **Clear Display**  
This instrument has the clearest design for setting the parameters of test voltage, current states, readings, procedures and states. All of them can be read from the display directly.
- **High/Low Limit Comparator for Pass/Fail Judgment**  
The function of high/low limit comparator for Pass/Fail judgment is designed for both withstanding and insulation resistance test. The HiPot low limit comparator and insulation high limit comparator are generally designed to prevent the misjudgment due to bad connection or test cable tripped. This function is able to detect if there is any bad connection or broken line.
- **Remote Control**  
This instrument can extend [START] and [RESET] signals to control externally. Usually they are connected to high voltage test gun or control case.

■ **Changing the Time for Voltage Rising**

This instrument contains [RAMP] function. This function is to change the time required for the outputted test voltage from zero rising to the specified value.

■ **Changing the Time for Voltage Falling**

This instrument contains [FALL] function. This function is to change the time required for the outputted test voltage from the specified value falling to zero.

■ **Current Range Auto Switch**

There are two HiPot test AC ranges, one is low AC range 0 ~ 3.000mA, the other is AC 3.01~20mA. There are three DC ranges, low current range 0 ~ 300uA, current range 0.301mA ~ 3mA and current range 3.01mA ~ 5.00mA. When the testing current is small, you can set if to switch the current range to the low one automatically for higher resolution via software as need.

■ **RS-232 Link (For link model of RS-232 only)**

The tester that can use RS-232 interface card and PC mainframe performs link test.

■ **RS-232 Link and RS-485 Interface Multi-Link Test (For link test model of RS-485 only)**

The tester that can use RS-232 interface card or install RS-485 interface card and PC mainframe performs link test. The maximum is 31 sets of instruments to process link test with PC mainframe as using RS-485 interface card simultaneously. Also, PC mainframe can control the setting and read the test data. When there is no PC mainframe, multi-link test can be performed individually but the test data can't be read.

## 1.3 Specifications (18°C ~ 28°C RH ≤ 70%)

□ Withstanding Voltage Test	
□ Test Voltage	AC: 0.05~5kV / DC: 0.05~6kV Constant Voltage (19072, 19073 only)
□ Voltage Regulation	≤ 1%+5V, Rated Load
□ V-display Accuracy	± (1% of reading + 5 counts), 2V resolution
□ Cutoff Current (Note1)	AC: 0.1mA ~ 20mA, DC: 0.01mA ~ 5mA (Note1), 0.1uAdc resolution
□ I-display Accuracy 0.1uA-299.9uA 0.3mA-2.999mA 3mA-20mA(5mAdc)	± (1.5% of reading + 5 counts) (Note2) WDC only
	± (1.5% of reading + 5 counts) (Note2)
□ Output Frequency	50Hz, 60Hz
□ Test Time	0.1 ~ 999 Sec, continue (Note3)
□ Dwell Time	0.1 ~ 999 Sec, off
□ Ramp Time	0.1 ~ 999 Sec, off (0.1sec approx.)
□ Fall Time	0.1 ~ 999 Sec, off
□ Arc Detection	
□ Setting Mode	Programmable Setting
□ Detection Current	AC: 1mA ~ 20mA, DC: 1mA ~ 5mA
□ Min. pulse width	10us approx.
□ GOOD/NO-GO Judgment Function	
□ Judgment System	<ul style="list-style-type: none"> <li>• Window comparator</li> <li>• A NO-GO judgment is made when a current greater than the high limit value or smaller than the low limit value is detected.</li> <li>• When a NO-GO judgment is made, the output voltage is cut out and a NO-GO alarm signal is delivered.</li> <li>• If no abnormal state is detected during the test time a GOOD Judgment is made and a GOOD signal is delivered.</li> </ul>
□ Insulation Resistance Test (19073 only)	
□ Test Voltage	DC: 0.05kV ~ 1kV, Constant Voltage
□ V-display Accuracy	± (5% of reading + 5 counts) (open voltage), 2V resolution
□ Resistance Range	0.1 MΩ ~ 50 GΩ (Note 4)
□ Measuring Accuracy	≥ 500V: 1MΩ ~ 1000MΩ: ± 4% + 5 counts 1GΩ ~ 10GΩ: ± 7% + 5 counts 10GΩ ~ 50GΩ: ± 12% + 5 counts < 500V: 0.1 MΩ ~ 1000MΩ: ± 7% + 5 counts < 100V: 0.1 MΩ ~ 1000MΩ: ± 10% + 5 counts
□ Secure Protection Function	
□ Fast Output Cut-off	Approx. 0.4mS, after NG happen
□ Fast Discharge	Approx. 0.2S, Typical
□ Ground Fault Interrupt	0.5mA ± 0.25mAac (ON), OFF
□ Continuity Check	0.1Ω ~ 5.0Ω ± 0.2Ω, GC MODE
□ Panel Operation Lock	YES
□ Memory Storage	

□ Memories, Steps	10 steps or 60 groups for total 60 memory location
<b>□ GO/NG Judgment Window</b>	
□ Indication, Alarm	GO: (Short Sound) NG: W-Arc, W-Hi, W-Lo, IR-Lo, IR-Hi, GFI (Long Sound)
<b>□ Remote Connector</b>	
□ Rear Panel 9 Pin D-type Connector	Input: Start, Stop, Interrupt Output: Under test, Pass, Fail
□ TEST/RESET Control	Low - active control (24V open voltage typical). Input requirements: <ul style="list-style-type: none"> <li>• Input time duration: 20msec. approx</li> </ul> The above input circuits are not isolated from other internal circuits.
<b>□ Options</b>	
□ RS-232 Interface	Baud rate: 4800 ~ 19200, data bits: 8, stop bit: 1
□ RS-485 Interface	A maximum of 32 devices connected to each bus
<b>□ Ambient Temperature and Relative Humidity</b>	
□ Specifications range	18 to 28°C (64 to 82°F), ≤ 70% RH.
□ Operable range	Maximum relative humidity 80% for temperature up to 31°C (88°F). Decreasing linearly to 50% relative humidity at 40°C (104°F) Altitude up to 2000m Indoor use only Pollution degree 2
□ Storage range	-10 to 60°C (-14 to 140°F), ≤ 80% RH.
□ Installation Category	CAT II
<b>□ Power Requirement</b>	
□ Line Voltage	AC 100V, 120V, 220V ± 10%, 240V +5 -10%
□ Frequency	50 or 60 Hz
□ Power	No load: < 60W
□ Consumption	With rated load: 300W max.
<b>□ General</b>	
□ Dimension	270(W) x 105(H) x 350(D) mm
□ Weight	Approx. 12kg
<b>□ Safety</b>	
□ Ground Bond	Less than 100mΩ at 25Amp, 3sec
□ Hipot	Less than 10mA at 1.5kVac, 3sec
□ Insulation Resistance	Over 100MΩ at 500V 3sec
□ Line leakage current	Less than 3.5mA at 127V, 3sec, normal, reverse

**Note**

1. AC set over 75VA, DC set over 22.5VA the maximum operating time is 60 seconds, and the same as rest time.  
The period of rest time is 1/2 duty of operating time. For full rating output, the line input range is +10% ~ -0%.
2. Only refer to 1.2kV resistance load.
3. IR test time is 0.3 sec ~ 999 sec.
4. Display resistance range is up to 60GΩ.

## 1.4 Standard Accessory

Item	Q'ty	Description
USA-type power cord	1	90° elbow USA-type power cord, length 1.8m
Power adapter	1	USA-type power cord 3P – 2P adapter
HV terminal used test cable	1	Alligator clip – cross HV head, red HV test cable, wire length 1m
LOW terminal used test cable	1	Alligator clip – banana plug, black HV test cable, wire length 1.2m
Test cable of grounding continue	1	Wire used in GC test, length 1.2m
3.15A fuse	2	For 3.15A SLOW 110VAC used
1.6A fuse	2	For 1.6A SLOW 240VAC used
Quick Start Guide	2	One English version and one Traditional Chinese version.
User's Manual CD	1	CD for user's manuals in English and Traditional Chinese

## 1.5 Optional Accessory

Item	Q'ty	Description
RJ-45 twin head link cable	1	L: 450mm
RJ-45 twin head link cable	1	L: 1000mm
RJ-45 twin head link cable	1	L: 2000mm
RJ-45 twin head link cable	1	L: 4000mm
DB-9F single head link cable	1	L: 7000mm
Across HV head + HV cable	1	L: 2000mm
Black banana head + HV cable	1	L: 2000mm

Remark: Optional accessory is for link test model of 19073 + RS485 only.

## 1.6 Initial Inspection

Before shipment, this instrument was inspected and found to be free of mechanical and electrical defects. As soon as the instrument is unpacked, inspect for any damage that may have occurred in transit. Save all packing materials in case that the instrument has to be returned. If damage is found, please file claim with carrier immediately. Do not return the instrument to Chroma without prior approval.



## 2. Operation and Setting

### 2.1 Front Panel

The front panel is divided into several function areas. This section explains each control and the information displays on LCD.

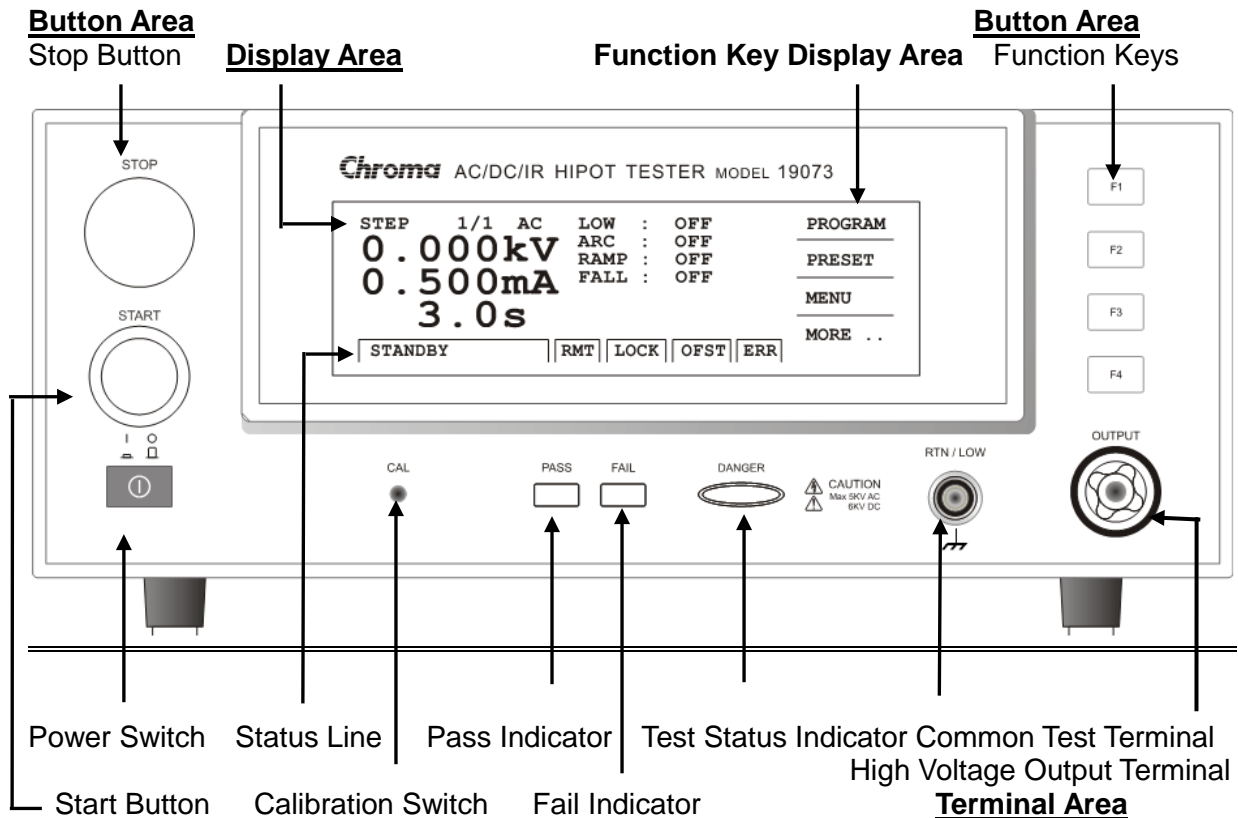

#### 2.1.1 Display Area

- **Function Key Display Area:** Different function text appears in different menu. The mapping function keys (F1-F4) are located at right. The function key is invalid if the text is blank.
- **Status Line:** This line shows the setting mode, value range, and test results.
- **RMT:** When the text is highlighted, it means the system is under on-line status.
- **LOCK:** When the text is highlighted, it means the system is under protection via parameter.
- **OFST:** When the text is highlighted, it means the leakage current has been offset by the system.

- **ERR**: When the text is highlighted, it means the system transmission is error.
- **Test State Indicator**: The DANGER indicator, when it lights up it indicates the instrument is under test condition and there is high voltage or mass current output on the test terminal. Do not touch the test terminal at this time.
- **Pass Indicator**: When it lights up it indicates the DUT passes the test. This indicator remains lit up until [STOP] is pressed.
- **Fail Indicator**: When it lights up it indicates the DUT fails the test. This indicator remains lit up until [STOP] is pressed.

## 2.1.2 Button Area

- **Power Switch**: The switch to supply the AC power source for this instrument.
- **Stop Button [STOP]**: Press this button the instrument will return to the ready state for testing and cut out output as well as clear all judgments.
- **Start Button [START]**: Press this button the instrument will be in test state, which means there are outputs at the test terminal and all judgment functions are activated.
- **Calibration Switch**: It is used by Chroma for calibration before shipping the product. Nonprofessional is prohibited to use this function to avoid causing any damage.
- **Function Keys**: There are different functions in different display menus. The mapping function description text is at right of the menu. The function key is invalid if the description text is blank.

## 2.1.3 Terminal Area

- **High Voltage Output Terminal**: The terminal of high voltage with high potential is located at high potential terminal for high voltage output. This test terminal is very dangerous especially when the DANGER indicator is lit up. Do not touch it when there is high voltage output.
- **Common Test Terminal (RET/LOW)**: It is the reference terminal at high voltage test, i.e. the low potential terminal almost equals to the chassis grounding.

## 2.2 Rear Panel

The rear panel is divided into several areas. This section describes the function of each area.

The standard rear panel of 19071/19072/19073:

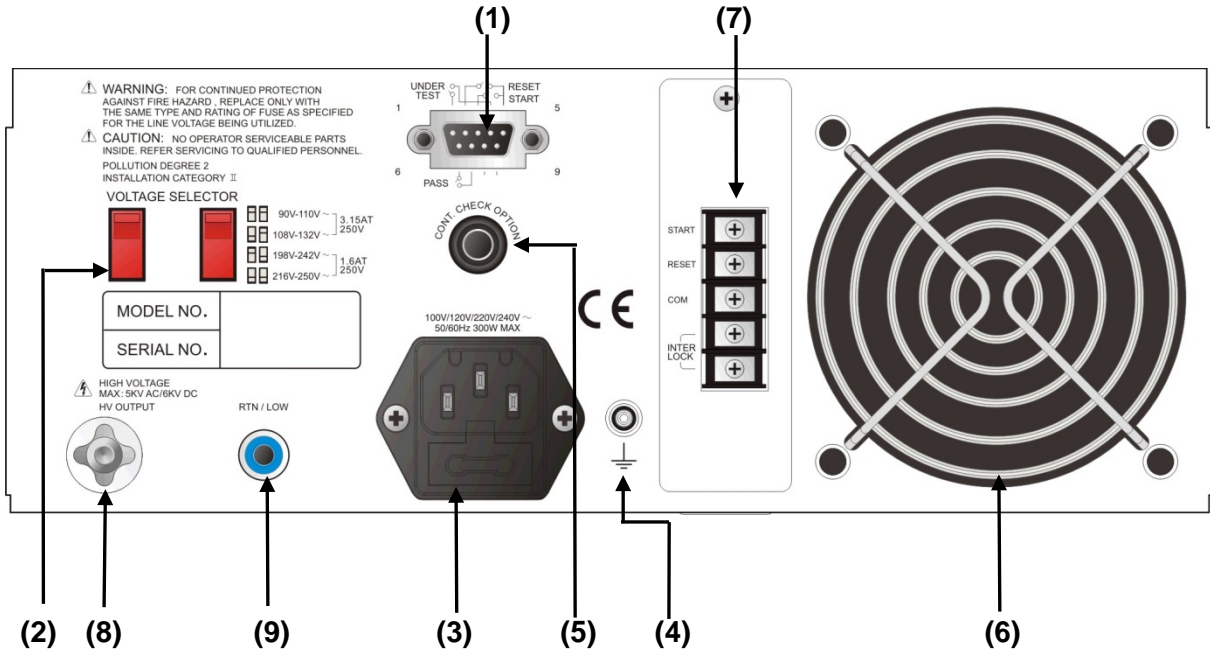

The rear panel of link test model of 19073 + RS232 is shown as below:

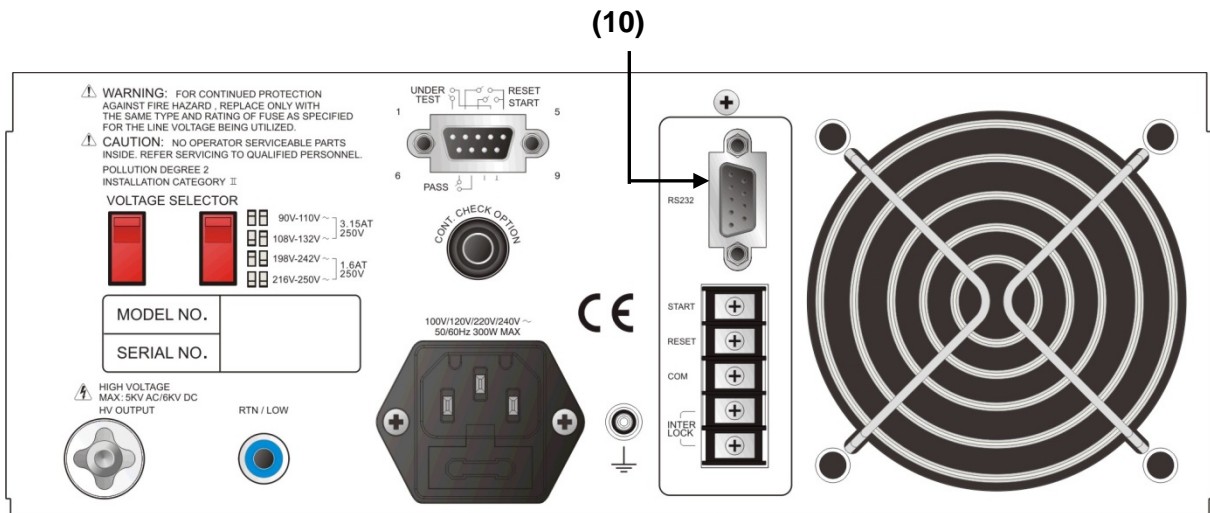

The rear panel of link test model of 19073 + RS485 is shown as below:

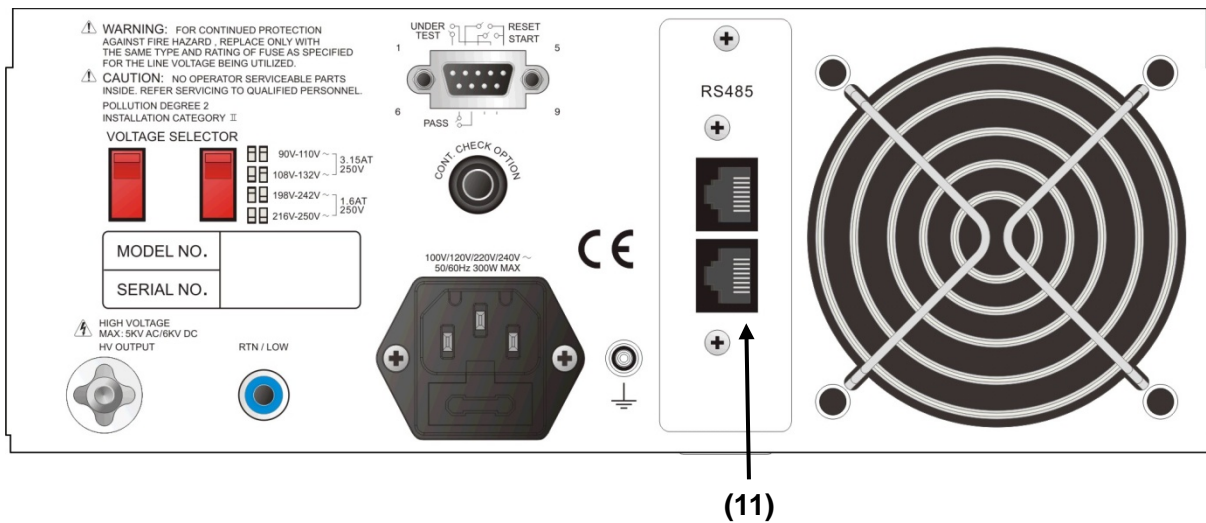

## (1) REMOTE CONTROL

■ The connection diagram of remote control signals is as the following.

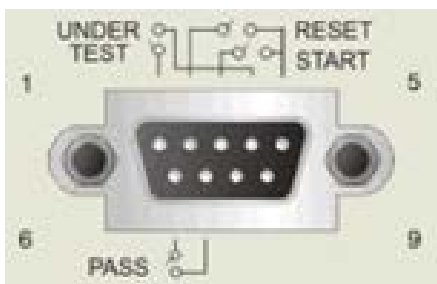

- START: The input terminal for start test signal.
- RESET: The input terminal for stop test signal.
- COM: The common input terminal for START and RESET signal.
- UNDER TEST: This terminal will short-circuit when in test mode, thus it can be used to control the external signal. The connecting point specification is 115V AC, current less than 0.3A. The action time is from the instrument enters the test mode until it is reset or completes the test.
- PASS: This terminal will short-circuit when the DUT passes the tests, thus it can be used to control the external signal. The connecting point specification is 115V AC, current less than 0.3A. The action time is from the DUT is passed until it is reset.

## (2) VOLTAGE SELECTOR: Input Power Range Switch

- To change the input AC power source for the following 4 types:
  - Voltage range 90V ~ 110V AC (3.15AT, 250V)
  - Voltage range 108V ~ 132V AC (3.15AT, 250V)
  - Voltage range 198V ~ 242V AC (1.6AT, 250V)
  - Voltage range 216V ~ 250V AC (1.6AT, 250V)

- Be sure to use correct fuse when switch the power source.

**(3) AC LINE: AC Power Socket and Fuse Holder**

It is a three-pin power socket and a fuse holder. AC power is inputted from this socket to supply the AC source needed by this instrument. For detailed usage and specification of fuse, see *Chapter 3 Installation and Maintenance*.

**(4) EARTH GROUND TERMINAL: Terminal Grounding for Safety**

Use appropriate tools to ground this terminal surely. If it is not grounded surely, when the power circuit or any other devices connection short-circuited with the ground terminal, the instrument chassis may contain high voltage. This is very dangerous as it may cause electric shock if anyone touches it under the situation; therefore, it is necessary to connect the ground terminal to earth assuredly.

**(5) CONTINUITY CHECK: Ground continue measuring and current output terminal**

This function is for detecting ground continues of DUT grounding terminal.

**(6) FAN**

The fan is activated simultaneously when the tester is powered on.

**(7) Expanded Slot**

The standard is 5PIN terminal slot, this slot provides the following functions:

- The connection diagram of expanded slot signals is as the following.

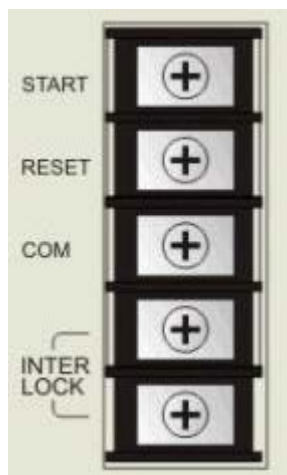

- START: Input terminal of starting test signal.
- RESET: Input terminal of stopping test signal.
- COM : Input common terminal of START and RESET signals.
- INTER LOCK: Short-circuited these two terminals, then can output high voltage.  
(This function is only for installing 5PIN on expanded slot. If this unit is link test model of 19073 + RS485, these two terminals are short-circuited fixedly.)

**(8) HV OUTPUT Terminal**

This terminal is the same as HV output terminal of front panel.

**(9) Common Test Terminal: RET/LOW**

This terminal is the same as common test terminal of front panel.

**(10)RS-232 Interface Card:**

This socket is for RS-232 interface which provided by the tester, it uses binary code transmission mode. Its command format is the same as RS-485 interface.

**(11)RS-485 Slot**

This slot supports two sockets of RJ-45, which provides multi-link function for the link test model of 19073 + RS485.

## 2.3 Operation

**[Standby Menu]:** The screen appears as below after powered on.

STEP 1/ 1 AC	LOW :OFF	PROGRAM
0.000KV	ARC :OFF	PRESET
0.500mA	RAMP:OFF	MENU
3.0s	FALL:OFF	MORE..
STANDBY	RMT	LOCK
	OFST	ERR

### 2.3.1 Memory Process

■ **How to enter the Memory Process menu**

(1) In **[Standby Menu]**, press the Function Key [MENU], it appears:

1. MEMORY	LAST
2. SYSTEM	DOWN
3. OPTION	SELECT
4. CALIBRATION	EXIT
5. KEY LOCK	
SELECT FUNC.	RMT
	LOCK
	OFST
	ERR

(2) Use Function Key [F1] and [F2] to move the highlight to “MEMORY”, and press Function Key [F3] to enter memory process menu as below:

1. (0 STEPS)	STORE
2. (0 STEPS)	RECALL
3. (0 STEPS)	DELETE
4. (0 STEPS)	RETURN
5. (0 STEPS)	
SELECT FUNC.	RMT
	LOCK
	OFST
	ERR

(3) At this time select execution action by pressed Function Key [F1], [F2] or [F3], it appears:

1. (0 STEPS)	LAST
2. (0 STEPS)	DOWN
3. (0 STEPS)	SELECT
4. (0 STEPS)	RETURN
5. (0 STEPS)	
SEL. MEMORY	RMT
LOCK	OFST
ERR	

- (4) At this time use Function Key [F1] and [F2] to move the highlight to the memory for processing, then press Function Key [F3] will prompt a confirmation window. Press Function Key [ENTER] to confirm and Function Key [UP] or [DOWN] to select stored character of file name. Press [NEXT.C] to select next character and [ENTER] to confirm the file name, the maximum file name is 10 characters.

1. (2 STEPS)HIPOT	UP
2. (0 STEPS)	DOWN
3. (0 STEPS)	ENTER
4. (0 STEPS)	CANCEL
5. (0 STEPS)	
SEL. MEMORY	RMT
LOCK	OFST
ERR	

- (5) When executing [RECALL] or [DELETE] function, use Function Key [F1] and [F2] to move the highlight to the memory for processing, then press Function Key [F3] will prompt a confirmation window. Press Function Key [YES] to confirm or Function Key [NO] to cancel, then can recall or delete the memory set. Each memory contains test parameters, preset parameters and number of test steps.

1. (2 STEPS)HIPOT	LAST
2. (0 STEPS)	DOWN
3. (0 STEPS)	SELECT
4. (0 STEPS)	RETURN
5. (0 STEPS)	
SEL. MEMORY	RMT
LOCK	OFST
ERR	

## 2.3.2 System Setup

### ■ How to enter the SYSTEM SETUP menu

- (1) In [Standby Menu], press the Function Key [MENU] and by using Function Key [F1], [F2] to move the highlight to "SYSTEM" and then press Function Key [F3] to enter into the parameter setting menu as below:

1.CONTRAST	:	<b>7</b>	INC.
2.BUZZER VOLUME:		HIGH	DEC.
3.EN50191	:	OFF	NEXT
4.DC 50V AGC	:	ON	
5.PASS ON	:	OFF	
1-15	RMT	LOCK	OFST
	ERR		RETURN

(2) Use Function Key [F3] to move the highlight to the parameter item you want to set, then use Function Key [F1] and [F2] to set the parameter data.

(3) System Parameter Setting Table

Item	Range	Default	Description
CONTRAST	1~15	7	Adjust the LCD brightness
BUZZER VOLUME	HIGH/MEDIUM/LOW/OFF	HIGH	Adjust the buzzer volume
EN50191	ON/OFF	OFF	The output meets to EN50191 requirement (AC Max 3mA, DC Max 5mA). The set and stored measurement parameters won't be affected as changing this setting.
DC 50V AGC	ON/OFF	ON	Select if open hardware AGC as DC / IR voltage setting is 50V~1000V. (When this item is OFF, hardware AGC is opened only DC voltage set to above 1001V automatically.)
PASS ON	OFF, 0.1sec-10sec	OFF	When set time to PASS ON, after the setting time for PASS ON is end then PASS signal will be deleted automatically. When set time to OFF, then PASS signal continue until press any key to delete.
END OF STEP	ON/OFF	OFF	When the setting is ON, as all STEPs are end the signal for Under Test will auto exit from 10mS. When the setting is OFF, only all STEPs are end the signal for Under Test will exit from 10mS.
EOT	END OF TEST / END OF TIMER	END OF TEST	1. END OF TEST (Pass & Fail & Under Test signals are activated after discharging.) 2. END OF TIMER (Pass & Fail & Under Test signals are activated before discharging.)

### 2.3.3 PRESET Parameter Setting

■ How to enter the PRESET menu

In [Standby Menu], press Function Key [PRESET] to enter the PRESET menu as shown below:

1.ACV FREQUENCY:	60Hz	UP
2.SOFTWARE AGC :	ON	DOWN
3.WV AUTO-RANGE:	OFF	NEXT
4.IR AUTO-RANGE:	ON	EXIT
5.GFI :	ON	
50Hz/60Hz	RMT	LOCK
	OFST	ERR

- (1) After entering the PRESET parameter setting menu, press Function Key [F3] to move the highlight to the parameter item you desired to set.
- (2) Press Function Key [F1] and [F2] to set the parameter data.
- (3) PRESET parameter function table as shown below:

Item	Range	Default	Description
ACV FREQUENCY	50 / 60 Hz	60Hz	It sets the output voltage frequency at AC HiPot test.
SOFTWARE AGC	OFF / ON	ON	It sets if to open the software AGC function.
WV AUTO-RANGE	OFF / ON	OFF	It sets if to open the HiPot auto range function.
IR AUTO-RANGE	OFF / ON	ON	It sets if to open the insulation auto range function.
GFI	OFF / ON	ON	It sets if to open the GFI function.
FAIL RESTART	OFF / ON	OFF	It sets if to restart directly when fails the test.
SCREEN	OFF/ON	ON	It sets if to display the test screen.

### 2.3.4 PROGRAM Parameter Setting

■ Test parameter setting

- (1) In [Standby Menu], press Function Key [PROGRAM] to enter the PROGRAM setting menu as the following:

STEP 1/1 AC	LOW : OFF	NEW
	ARC : OFF	MORE..
VOLT :0.050kV	RAMP : OFF	NEXT
HIGH :0.500mA	FALL : OFF	EXIT
TIME : 3.0s		
1-10	RMT	LOCK
	OFST	ERR

■ Test steps setting

- (1) Press [F3] to move the highlight and stay in the test item. When Function Key [F1] shows "UP", it means press this key can switch to the next test step. When Function

Key [F1] shows “NEW”, it means press this key can add a test step. When Function Key [F1] shows “FIRST”, it means press this key can switch the first test step.

(2) Use Function Key [F2] can switch the functions as shown below:

STEP 2/2 AC	LOW : OFF	DELETE
VOLT :0.500kV	ARC : OFF	INSERT
HIGH :0.500mA	RAMP : OFF	DOWN
TIME : 3.0s	FALL : OFF	RETURN
VOLTAGE IS 0	RMT	LOCK
	OFST	ERROR

- (3) Function Key [DELETE] to delete a selected test step.
- (4) Function Key [INSERT] to insert a new test step set.
- (5) Function Key [DOWN] to select to previous test step set.

■ **Selecting Test Mode**

Press Function Key [F3] to move the highlight and stay in the test item. Use Function Key [F1] and [F2] to select the test mode. There are AC/GC/PA/OS, AC/DC/GC/PA/OS and AC/DC/IR/GC/PA/OS test modes for selection by different model. Different test mode has different test parameters for setting.

■ **Description of each test parameter setting:** The following explain the parameter setting of each test mode.

(1) **AC HiPot Test Mode**

STEP 1/1 AC	LOW : OFF	UP
VOLT:0.000kV	ARC : OFF	DOWN
HIGH:0.500mA	RAMP: OFF	NEXT
TIME: 3.0s	FALL: OFF	EXIT
SELECT MODE	RMT	LOCK
	OFST	ERR

- VOLT : Set the required voltage for HiPot test.
- HIGH : Set the upper limit for leakage current.
- TIME : Set the required time for testing, 0 means continuous test. (Judge the high and low limit for leakage current during the time.) The voltage value is shown which within specification, the minimum test time should be ≥ 0.3 second. When the displayed voltage is not reach to 9/10(Software AGC ON) or 2/3(Software AGC OFF) of setting voltage value, the judgment function will show FAIL.
- LOW : Set the low limit for leakage current, 0 means OFF.
- ARC : Set the high limit for ARC, 0 means OFF.
- RAMP : Set the required time for rising to selected voltage, 0 means OFF.
- FALL : Set the required time for falling from selected voltage to zero, 0 means OFF.

**(2) DC HiPot Test Mode**

STEP 1/1	<b>DC</b>	LOW : OFF	UP
		ARC : OFF	
VOLT :0.000kV		RAMP : OFF	DOWN
HIGH :0.500mA		DWELL: OFF	
TIME : 3.0s		FALL : OFF	NEXT
		I-RUS: OFF	
SELECT MODE	RMT	LOCK	OFST
		ERR	EXIT

- VOLT : Set the required voltage for HiPot test.
- HIGH : Set the high limit for leakage current.
- TIME : Set the required time for testing, 0 means continuous test. (Judge the high and low limit for leakage current during the time.) The voltage value is shown which within specification, the minimum test time should be  $\geq 0.2$  second. When the displayed voltage is not reach to 9/10(Software AGC ON) or 2/3(Software AGC OFF) of setting voltage value, the judgment function will show FAIL.
- LOW : Set the low limit for leakage current with the value less than the high limit for leakage current or OFF.
- ARC : Set the high limit for ARC, 0 means OFF.
- RAMP : Set the required time for rising to selected voltage, 0 means OFF.
- DWELL : Set DWELL time, 0 means OFF. (Do not judge the high and low limit for leakage current during DWELL TIME operation, but do not over the high limit of setting range.)
- FALL : Set the required time for falling from selected voltage to zero, 0 means OFF.
- I-RUS : Select if detection charge current over low function is activated.

**(3) Insulation Resistance Test Mode**

STEP 1/1	<b>IR</b>	HIGH : OFF	UP
		RANGE: AUTO	
VOLT :0.000kV		RAMP : OFF	DOWN
LOW : 1.0MΩ		DWELL: OFF	
TIME : 3.0s		FALL : OFF	NEXT
SELECT MODE	RMT	LOCK	OFST
		ERR	EXIT

- VOLT : Set the required voltage for insulation resistance test.
- LOW : Set the low limit for insulation resistance.
- TIME : Set the time required for test, 0 means continuous test. (Judge the high and low limit for insulation resistance during the time.)
- HIGH : Set the high limit for insulation resistance with the value larger than the low limit of insulation resistance or OFF.
- RANGE : Set the current test range of insulation resistance, AUTO indicates auto switch range. The relation of current range and resistance measurement range is shown as below.

Range	IR Display Value	
	Setting Voltage 50V ~ 250V	Setting Voltage 250V ~ 1000V
5mA(3~5mA)	0.10MΩ ~ 0.10MΩ	0.10MΩ ~ 1.00MΩ
3mA(0.3~3mA)	0.10MΩ ~ 0.90MΩ	0.10MΩ ~ 3.50MΩ
300uA(30~300uA)	0.10MΩ ~ 9.00MΩ	0.10MΩ ~ 25.00MΩ 22.0MΩ ~ 35.0MΩ
30uA(3~30uA)	0.10MΩ ~ 25.00MΩ 22.0MΩ ~ 90.0MΩ	0.10MΩ ~ 25.00MΩ 22.0MΩ ~ 250.0MΩ 0.220GΩ ~ 0.350GΩ
3uA(0.3~3uA)	22.0MΩ ~ 250.0MΩ 0.220GΩ ~ 0.900GΩ	25.0MΩ ~ 250.0MΩ 0.220GΩ ~ 2.500GΩ 2.20GΩ ~ 3.33GΩ
300nA(20~300nA)	0.200GΩ ~ 2.000GΩ	0.200GΩ ~ 2.500GΩ 2.20GΩ ~ 50.00GΩ

**Note** : Select IR suitable current range please follow test voltage and DUT insulation resistance for counting the quantity of current then follow it to select suitable current range.

RAMP: Step-up setting voltage needed time, 0 means OFF.

DWELL: Set the required time for test, 0 means OFF. (Do not judge the high and low limit for insulation resistance during this period.)

FALL : Set the required time for falling from selected voltage to zero, 0 means OFF.

#### (4) Ground Continue Mode

STEP 1/1	<b>GC</b>	LOW : OFF	UP
CURR :	0.0A		DOWN
HIGH :	1.0Ω		NEXT
DWELL:	0.3s		EXIT
SELECT MODE	RMT	LOCK	OFST
		ERR	

CURR : Set the output current (0.1A maximum).

HIGH : Set the high limit of ground continue (0.1Ω ~ 5Ω).

DWELL : Set the time required for test (0.1 sec ~ 1 sec). (Do not judge the high and low limit for ground continue during the time.)

LOW : Set the low limit for ground continue with the value lower than the high limit of ground continue or OFF.

#### (5) Pause Mode

STEP 1/1	<b>PA</b>	UP
PAUSE:PAUSE-MODE		DOWN
UNDER TEST SIGNAL:OFF		NEXT
SELECT MODE	RMT	LOCK
		OFST
		ERR
		EXIT

- PAUSE : Set the signal shown on menu when pause, the maximum length is 15 characters.
- UNDER TEST SIGNAL: Set UNDER TEST signal on the rear panel and DANGER indicator on the front panel when pause.

**(6) Open/Short Detection Mode (OS)**

STEP 1/1	<b>OS</b>	OPEN : 50%	UP
		SHORT: OFF	DOWN
			NEXT
			EXIT
SELECT MODE	RMT	LOCK	OFST
		ERR	

- OPEN : Set the judgment test result is the condition for open(compare the test reading with the standard capacitance value[Cs] be read).
- SHORT : Set the judgment test result is the condition for short(compare the test reading with the standard capacitance value[Cs] be read).

## 2.4 How to Perform Tests

■ **Test Cable Offset Calibration**

- (1) In **[Standby Menu]**, press Function Key [MORE..] to enter the test menu of multiple STEPS.
- (2) Press Function Key [OFFSET], the monitor will show a menu to indicate you to open the output terminal.
- (3) Press [START], the DANGER indicator on the front panel will light up. The test time is 5 seconds. The system starts to measure the test cable offset and shows the reading on monitor, then saves it to memory.

■ **Connection the DUT**

First, ensure there is no voltage output and the DANGER indicator is off. Then connect the low potential test cable (black) to the common test terminal on system, and secure it with fixed plate. Short-circuit the test cable and high voltage output terminal. After confirming no high voltage is output, connect the DUT with low potential test cable first and high potential test cable later, and then plug in the high voltage test cable (red or white) to “High Voltage Output Terminal”.

■ **Test Steps(AC/DC/IR/GC)**

- (1) Connection the DUT with correct procedures.
- (2) In **[Standby Menu]** (as shown below):

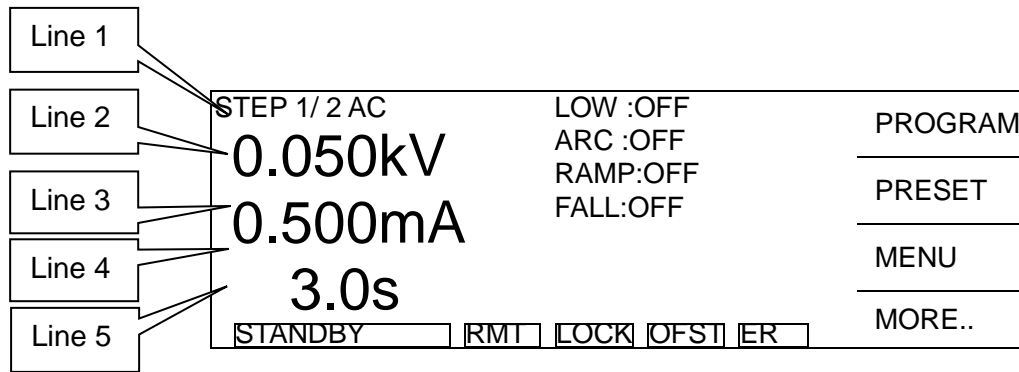

1. STEP 1/2 in "Line 1" indicates there are 2 test steps, and currently it is executing step 1. M02 1/2 in "Line 1" indicates this test parameter set have saved into the index 2 memory. There are 2 test steps in the memory, and currently it is executing step 1.
2. AC in "Line 1" indicates this step is AC HiPot test mode.
3. "Line 2" indicates the output voltage set for test.
4. "Line 3" indicates the high limit for leakage current under STANDBY state in AC or DC HiPot test mode; or the low limit for insulation resistance under STANDBY state in IR test mode. When in TEST mode, it is the value of real leakage current or insulation resistance.
5. "Line 4" indicates the testing time set under STANDBY state; or the remaining testing time under TEST state.
6. "Line 5" is the "Status Line" that shows the current state or test results.

(3) Press [STOP] to enable it standby for test and the "Status Line" shows "STANDBY".

(4) Press [START] to begin the test. It will begin to output the test voltage. The DANGER indicator lights up and the "Status Line" shows "UNDER TEST" to warn you that it is in test state and there is mass voltage output. "Line 2" will show the output voltage reading, "Line 3" will show the reading of leakage current or insulation resistance, and "Line 4" performs timing and countdown work.

(5) PASS Judgment

When all test steps are done and "Status Line" shows PASS, it indicates the DUT is a quality product. Then the output is cut out, rear panel outputs the PASS signal and buzzer (short beep) in the meantime.

(6) FAIL Judgment

If the measurement is abnormal, the system will judge the DUT as a failed product and cut out the output. The rear panel outputs FAIL signal and buzzer (long beep) in the meantime. The action continues until [STOP] key is pressed. "Status Line" will show fail state as below. Please see page 2-16 "Description Table for Test Result".

(7) If any errors happen and cause the [START] key to be locked, you can press [STOP] to release it.

(8) You can press [STOP] key anytime to stop the test output in any case.

■ **Test Steps (OS)**

- (1) Connection the DUT with correct procedures.
- (2) In **[Standby Menu]** (as shown below):

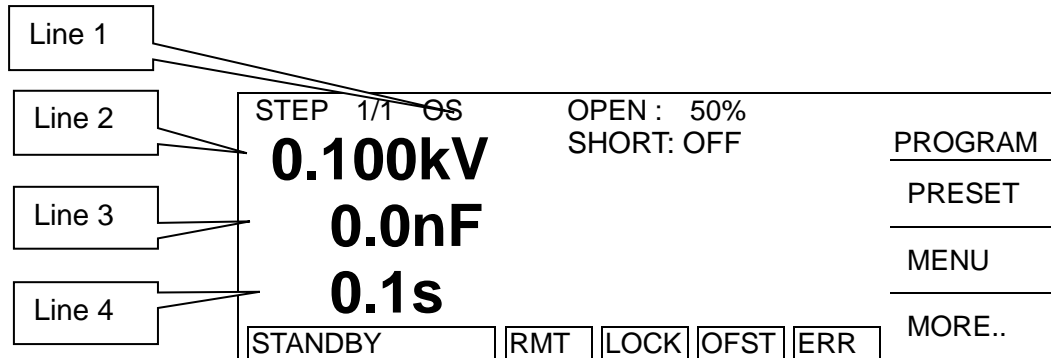

1. OS in “Line 1” indicates this step is **open/short detection mode**.
2. “Line 2” indicates the output voltage set for test.
3. “Line 3” indicates the capacitance value for reading.
4. “Line 4” indicates the test time.

- (3) Press [STOP] to enable it standby for test and the “Status Line” shows “STANDBY”.
- (4) Please press [MORE..] to enter the test menu of multiple STEPS, the menu as shown below:

	OUTPUT	MEASURE	RESULT	OFFSET
1	OS 0.100kV	0.0nF	-----	-----
				GET Cs
				-----
				MORE..

STANDBY | RMT | LOCK | OFST | ERR | MORE..

1. Please press [OFFSET] to perform OFFSET elimination at first. It is need to perform OFFSET elimination again when change the wire or fixture every time. This is for ensure the accuracy for the test.
2. It is need that the capacitance standard sample for the test as the DUT when test or change new DUT of capacitance. Press [GET Cs] to read the standard capacitance value for the value when test.
3. Please press [MORE..] again to back to standby menu.
4. Press [START] to begin the test. It will begin to output the voltage. The DANGER indicator lights up and the “Status Line” shows “UNDER TEST” to warn you that it is in test state and there is voltage output. “Line 2” will show the voltage output reading, “Line 3” will show the reading of capacitance, and “Line 4” performs timing and countdown work.

Note: When test OSC Mode, Get Cs current range at this time decides the display of capacity effective digit.

Example: Get Cs voltage 0.018kV, Get Cs capacitance value 17.4nF, current= 1.18mA -- at the mass current range

Get Cs voltage 0.016kV, Get Cs capacitance value 17.42nF, current= 0.97mA -- at the medium current range

(5) PASS Judgment

When all test steps are done and "Status Line" shows PASS, it indicates the DUT is a good product. Then the output is cut off, rear panel outputs the PASS signal and buzzer (short beep) in the meantime.

(6) FAIL Judgment

If the measurement is abnormal, the system will judge the DUT as a failed product and cut off the output. The rear panel outputs FAIL signal and buzzer (long beep) in the meantime. The action continues until [STOP] key is pressed. "Status Line" will show fail state as below. Please see page 2-16 "Description Table for Test Result".

(7) If any errors happen and cause the [START] key to be locked, you can press [STOP] to release it.

(8) You can press [STOP] key anytime to stop the test output in any case.

■ Description Table for Test Result

Test Result	Meaning
PASS	Passed the tests judged as PASS product
HIGH FAIL	Measurement is over the high limit
LOW FAIL	Measurement is under the low limit
OPEN FAIL	Capacitance open/capacitance reading is lower than the setting of OPEN.
SHORT FAIL	Capacitance short/capacitance reading is higher than the setting of SHORT.
ARC FAIL	Current ARC is over the high limit
I/O FAIL	Hardware detects bad signal (It maybe short circuit of DUT).
NO OUTPUT	Output is not enough (It maybe the test time is not enough).
VOLT OVER	Voltage reading is over the hardware valid digits.
CURR OVER	Current reading is over the hardware valid digits.
INRUSH FAIL	Charging current is over low (It maybe test fixture bad contact).
GFI TRIPPED	Grounding failed interrupted
SLAVE FAIL	SLAVE communication fails
SKIPPED	The step is skipped. To skip the step don't need to implement as conducting Get Offset or Get Cs.
Cs/SHORT FAIL	The Cs is too high. To stop the detection of SHORT may be resolve this problem.

## 2.5 Other User Setting Function

### 2.5.1 KEY LOCK Function

#### ■ Setting KEY LOCK

In **[Standby Menu]**, you can enable KEY LOCK function if **[LOCK]** is not highlighted.

- (1) Press Function Key [MENU], use Function Key [F1] and [F2] to move the highlight to "KEY LOCK", and press Function Key [SELECT] to enter into the KEY LOCK setting menu.

KEY LOCK	A
USER PASSWORD:****	B
	ENTER
	RETURN
1-10 CHAR. <input type="text"/>	RMT   LOCK   OFST   ERR

- (2) Use Function Key [A] and [B] to input the PASSWORD (default is AAAA.)

- (3) Press Function Key [ENTER] will prompt a selection window is highlighted.

KEY LOCK ON !	YES
RECALL LOCK ?	NO
	CANCEL
YES/NO <input type="text"/>	RMT   LOCK   OFST   ERR

- (4) You can press Function Key [YES] or [NO] to select if lock the MEMORY RECALL function as well. Exit the menu after completing KEY LOCK function and **[LOCK]** is highlighted in the meantime.

- (5) Press Function Key [CANCEL] to cancel the action and exit the set menu.

#### ■ Canceling KEY LOCK

In **[Standby Menu]**, you can release KEY LOCK if **[LOCK]** is highlighted. Follow the steps above to cancel KEY LOCK, and **[LOCK]** will not be highlighted.

### 2.5.2 Auto Range

- (1) Set WV-AUTO RANGE as ON under PRESET function list.
- (2) The current set to high range as below shown.

STEP 1/1 AC	LOW : OFF	PROGRAM
<b>0.050kV</b>	ARC : OFF	PRESET
<b>20.00mA</b>	RAMP : OFF	MENU
<b>3.0s</b>	FALL : OFF	MORE..
STANDBY	RMT	LOCK
OFST	ERR	

- (3) The test is ended before 0.6 sec, if the current is shown as low range then the current auto range to low range as the following figure.

STEP 1/1 AC	LOW : OFF	PROGRAM
<b>0.050kV</b>	ARC : OFF	PRESET
<b>0.100mA</b>	<b>PASS</b>	MENU
<b>0.0s</b>		MORE..
PASS	RMT	LOCK
OFST	ERR	

### 2.5.3 Change User Password

- (1) In **[Standby Menu]**, press Function Key [MENU], and use Function Key [F1] and [F2] to move the highlight to "CHANGE PASSWORD" and press Function Key [SELECT] to enter into the password menu.

CHANGE PASSWORD	A
USER PASSWORD:****	B
	ENTER
1-10 CHAR.	RETURN
RMT	LOCK
OFST	ERR

- (2) Use Function Key [A] and [B] to input the original PASSWORD (default is AAAA), and press Function Key [ENTER] will show the following "NEW PASSWORD" window.

CHANGE PASSWORD	A
NEW PASSWORD:****	B
	ENTER
1-10 CHAR.	RETURN
RMT	LOCK
OFST	ERR

- (3) Use Function Key [A] and [B] to input the NEW PASSWORD (maximum 10 characters), and press Function Key [ENTER] will display the "CONFIRM" window.

CHANGE USER PASSWORD	A
CONFIRM:	B
	ENTER
1-10 CHAR. [ ] LOCK OFST [ ]	EXIT

- (4) Use Function Key [A] and [B] to input the NEW PASSWORD, and press Function Key [ENTER]. Press [RETURN] after completing the setting.

## 2.5.4 Remote Control

- **Be aware** when using remote control by external signal and do not touch the high voltage terminal to avoid causing any danger.
- The REMOTE outlet for remote control switch is located at the rear panel. You can plug in the control line to use external signal for controlling the device output externally.
- Remote control is usually done by high voltage testing bar; however, you can also use other control circuit to do it. Be careful that it is the switch to control high voltage output, so you must connect the control line with caution and do not get near the high voltage terminal and test cable to avoid causing any danger.
- For single control of START and RESET signals follow *Figure 2-1* listed below to connect them to the REMOTE position on the system back panel.
- If it is connected as *Figure 2-2* shows, the system routine is in RESET state as the NC is connected to RESET and NO is connected to START.

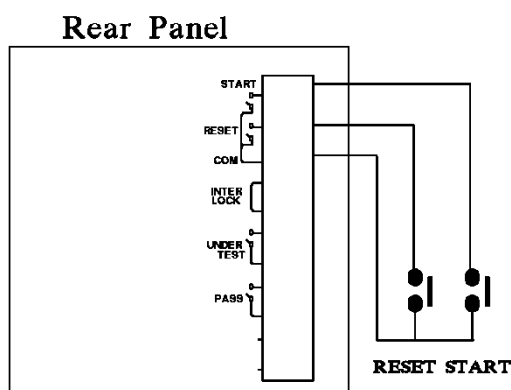

Figure 2-1

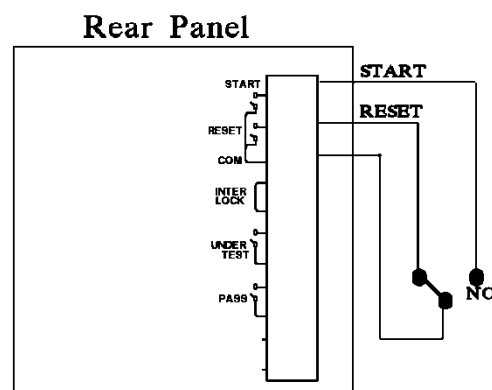

Figure 2-2

- The logic components of transistor, FET and couplers can be connected and used as control circuit. The connected signals and circuit are shown as below. To use this circuit to control the system, it must contain the following:
  - (1) The current of LOW signal is 2mA or less.
  - (2) The active time for input signal is more than 20mS.

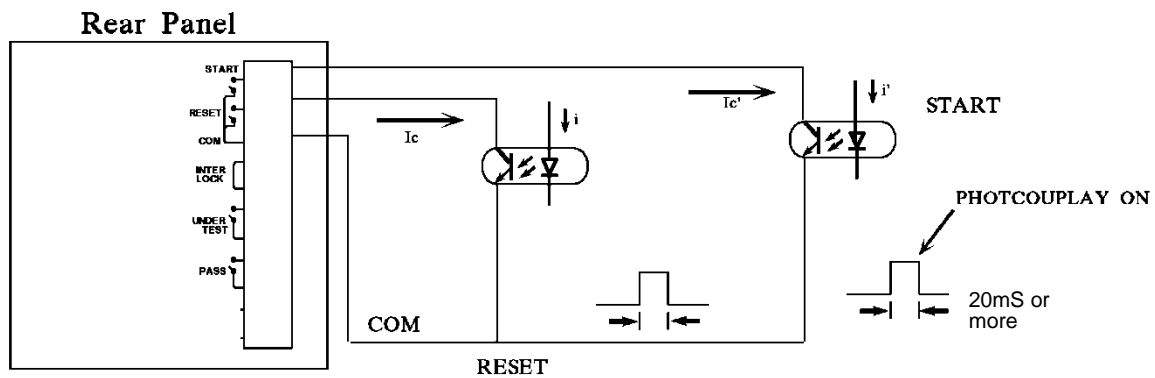

Figure 2-3

- Either the relay switch control in *Figure 2-1* or the coupler control in *Figure 2-3* uses the contact of components for control action. It can prevent the error operation from interference effectively. Though the system has a lot of precautions, you would still need to watch out the interference caused by the measurement system settings.
- Pin diagram of REMOTE CONTROL as *Figure 2-4*. When users to control by external, please remember this pin diagram.

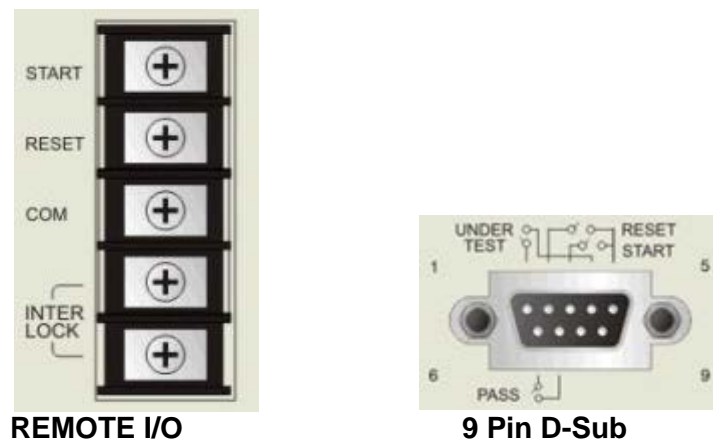

Figure 2-4

## 2.5.5 Output Signal

This instrument has indicator and beeper for indication signals. The output signals in the system rear panel are:

- UNDER TEST: This terminal will short-circuit when in test mode, thus it can be used to control the external signal. The connecting point specification is 115V AC, current less than 0.3A.
- PASS: This terminal will short-circuit when the DUT passes the tests, thus it can be used to control the external signal. The connecting point specification is 115V AC, current less than 0.3A. The action time is from the DUT is passed until it is stopped.

## 2.5.6 Timing Diagram

(1) Set "END OF STEP" to OFF

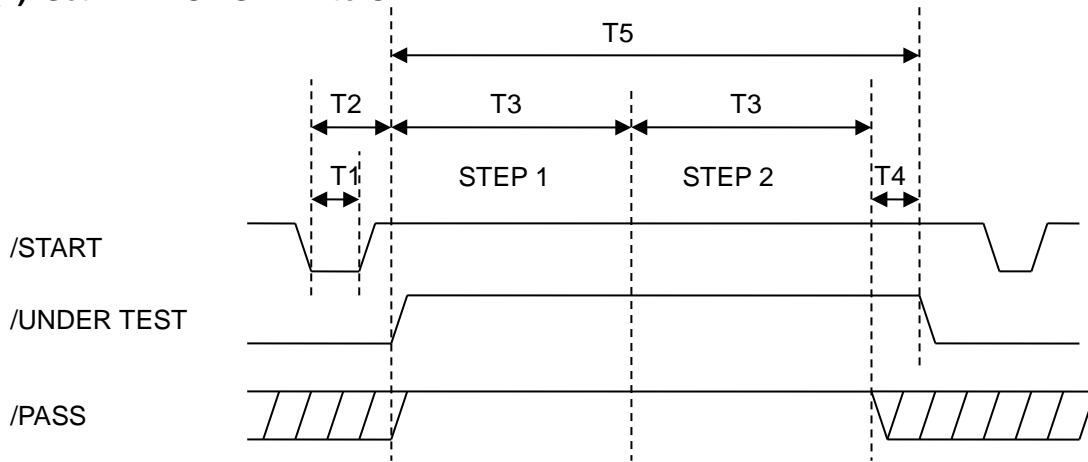

Timing diagram – take an example by two test steps

Time	Limit	Description
T1	> 20mS	The time of external trigger signal (/START) to be remained which needs larger than 20mS.
T2	< 200mS	The time of external trigger signal /START to /UNDER TEST signal to be cleared, it will be smaller than 200mS. The previous STEP test result /PASS signal status has been cleared in advance.
	< 300mS	The time of external trigger signal /START to /UNDER TEST signal to be cleared, it will be smaller than 300mS. The previous STEP test result /PASS signal status hasn't been cleared in advance.
T3	-	Test needed time of various test steps.
T4	> 5mS	/Pass signal sent larger than 5mS, /UNDER TEST signal is end.
T5	-	The equipment used time as testing, the signal is simultaneous with Danger lamp on panel.

(2) Set "END OF STEP" to ON

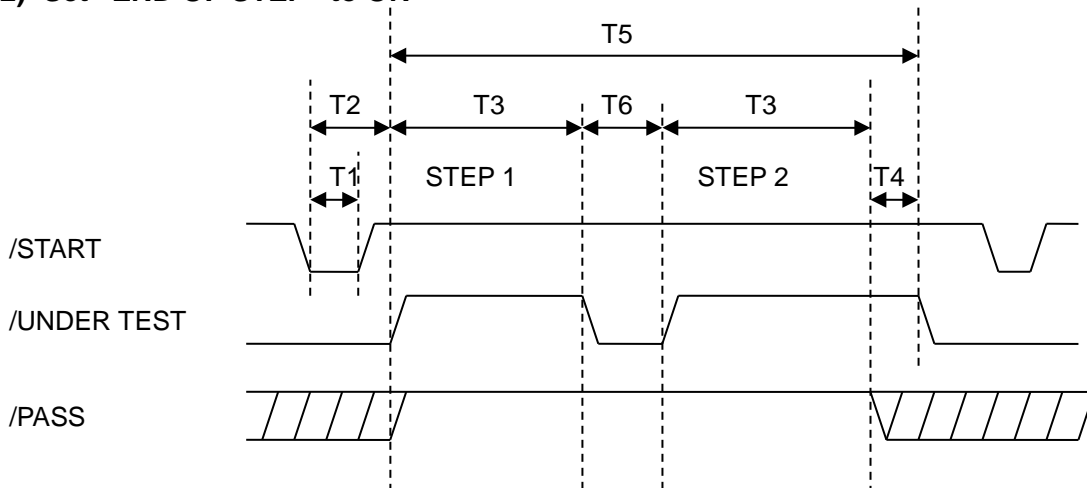

Timing diagram – take an example by two test steps

Time	Limit	Description
T1	> 20mS	The time of external trigger signal (/START) to be remained which needs larger than 20mS.
T2	< 200mS	The time of external trigger signal /START to /UNDER TEST signal to be cleared, it will be smaller than 200mS. The previous STEP test result /PASS signal status has been cleared in advance.
	< 300mS	The time of external trigger signal /START to /UNDER TEST signal to be cleared, it will be smaller than 300mS. The previous STEP test result /PASS signal status hasn't been cleared in advance.
T3	-	Test needed time of various test steps.
T4	> 5mS	/Pass signal sent larger than 5mS, /UNDER TEST signal is end.
T5	-	The equipment used time as testing, the signal is simultaneous with Danger lamp on panel.
T6	>10mS	When the setting of "END OF STEP" is ON, /UNDER TEST signal OFF time is larger than 10mS between STEP and STEP.

## 3. Installation and Maintenance

### 3.1 Notices for Installation

This instrument generates high voltage output up to 6KV for external test. Any incorrect or mistaken procedures in using this instrument may cause injury or death. Thus for your safety, be sure to read through the notices described in this chapter and memorize them to prevent any accidents from happening.

#### ■ Induction and electric shock

To avoid electric shock, we suggest you to put on the insulation rubber gloves before performing any electricity related work.

#### ■ Grounding

There is a safety grounding terminal at the instrument rear panel. Ensure to use appropriate tools to connect the grounding terminal surely. If it is not grounding correctly, the chassis of test machine may contain high voltage when the power circuit or the connecting line of any devices short-circuited with the grounding terminal. This is very dangerous as it may cause electric shock if anyone touches the instrument under the circumstances. Therefore, it is necessary to connect the safety grounding terminal to earth correctly. See section 2.2 *Rear Panel* for detail information.

#### ■ Connecting test cable to the “Common Test Terminal”

Please connect the test cable to “Common Test Terminal” actually. Always check if the test cable is connected properly during test. When you need to connect the test cable to the unit for test, use the one on Common Test Terminal first to connect the DUT. It is very dangerous if the test cable on Common Test Terminal is not connected completely or loose as the entire DUT may contain high voltage. Refer to section 2.1 *Front Panel*.

#### ■ Connecting test cable to the “High Voltage Output Terminal”

Follow the procedures below to connect the high voltage output line after the “Common Test Terminal” is connected.

- Press [STOP] button first.
- Ensure the DANGER indicator is off.
- Short circuit the “Common Test Terminal” test cable and “High Voltage Output Terminal”, and ensure there is no voltage output.
- Last, connect the “Common Test Terminal” test line to the DUT and then the high voltage test cable to the DUT.
- Plug in the high voltage test cable to the “High Voltage Output Terminal”.

#### ■ End test

When tests are done and the test instrument is not in use or need to leave for a while during usage, make sure to turn off the power switch (to O). See section 2.1 *Front Panel* for detail information.

#### ■ Dangerous places when the instrument is in test mode

It is very dangerous to touch the area with high voltage such as the DUT, test cable, probe, and output terminal when the instrument is in test mode.

※ **DO NOT touch the alligator clip as shown below on the test cable when the system is in test mode as the rubber insulation is not good enough and may**

cause danger if touched.

Don't touch here when outputting high voltage.

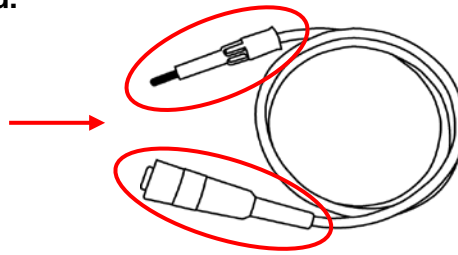

■ **End test confirmation**

You may touch the DUT, high voltage test cable or high voltage output area like output terminal in order to alter the layout or perform particular test request, thus be sure to turn off the power before doing it. For testing the DC HiPot/insulation resistance, the DUT may contain high voltage after completing the test, so you need to carefully follow the instructions described in this chapter to perform the work.

### 3.1.1 Charging During DC HiPot/Insulation Resistance Test

■ **Charge**

When doing DC HiPot/insulation resistance test, the DUT, capacitor, test cable, probe and output terminal, even the test instrument may charge with high voltage. The charged voltage may need a period of to discharge after the power switch is turned off. Do not touch any places that may cause electric shock as mentioned above especially at the moment of turning off the power.

■ **Confirming the charged voltage is discharged totally**

the test voltage applied as well as the DUT characteristics determine the total discharge time for the charged voltage. Assuming the high voltage on the DUT is the voltage plus a 0.01uF capacitor paralleling a 100MΩ resistance circuit, then after turning off the power the voltage on test instrument and DUT takes about 3.5 seconds to decrease to 30V. Thus when the test voltage is 500V, it needs about 2.8 seconds. Suppose we already know the time constant of a DUT, you can follow the description above to calculate the time required for voltage decreasing to beneath 30V after turning off the power. The method is using the time decreased to under 30V multiplies the time constant ratio as the figure shown below.

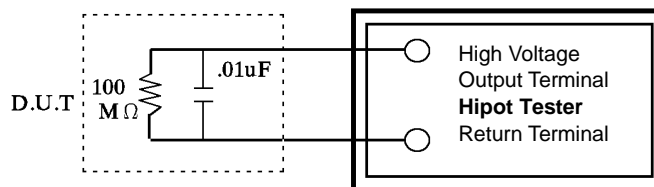

<Formula>

$$\text{Test Voltage} * e^{-t/RC} = \text{Residual Voltage}$$

$$\text{Ex.: } 1000V * e^{-t/RC} = 30V$$

$$\ln^{-t/RC} = \ln 0.03$$

$$- t / RC = -3.5$$

$$t = 3.5 \text{ sec}$$

■ **Remote control system**

This system is capable of remote control. Usually it uses external control signal to do the high voltage output control. For your safety and to prevent accidents, the following principles of control must be performed accurately. Do not allow any unexpected high voltage output to cause any hazards. When the system has high voltage output, operators and other personnel are not allowed to touch the DUT, test cable and probe and output terminal, etc.

■ **Turn the power switch on or off** ※Attention※

The product should be so positioned that the power switch can be easily reached by the operator during emergency. Once the power switch is cut off, wait a few seconds to turn it on again. Do not turn on/off the power switch repeatedly to avoid causing any errors. It is very dangerous to do repeating power on/of in high voltage output state.

**The high voltage output terminal cannot connect to any objects during power on or off to avoid hazards caused by abnormal high voltage output.**

■ **Miscellaneous notices**

Do not short circuit the instrument output line, grounding line, transmission line, or other connector grounding line, and AC source to avoid the entire test device being charged to a very dangerous voltage. To short circuit the High Voltage Output Terminal and Common Test Terminal, the instrument chassis must be grounded to earth first.

## 3.1.2 Emergency Events

■ **Emergency management**

In the emergency situations of electric shock, DUT on fire or system on fire, follow the steps below to avoid causing bigger hazards.

- First, cut off the power switch.
- Then, unplug the power cord.

## 3.1.3 Solving Problems

■ **When problem happens**

The problems in the following conditions are very dangerous. The output terminal may still have high voltage output even the [STOP] button is pressed, so you need to be very careful.

- The DANGER indicator still lights up after the [STOP] button is pressed.
- There is no reading on voltage meter, however the DANGER indicator is lit.  
When any of the above conditions happens, turn off the power and unplug the AC power cord. Do not use it again as the failure is very dangerous. Send it back Chroma or dealer for repair and services.

■ **DANGER indicator failure**

If you press the [START] button and the voltage meter shows readings but the DANGER indicator is still off, it means the indicator may be failure. Turn the instrument off and replace it immediately, then return the malfunction device to Chroma or dealer for repair and services.

■ **Notices when operating the instrument of long duration under normal condition**

If the setting high limit closes to the rated value, pay attention to the temperature changes. Stop using it if the ambient temperature is over 40°C. Wait until the

temperature is down to normal to resume the operation, and the instrument must be inspected first.

■ **There are four types of AC INPUT power source used in this instrument**

Switch the voltage selector on the rear panel to the correct position according to the voltage used locally. Ensure the AC power source is same as marked on the power switch that located on the rear panel, and the fuse is changed to the appropriate one when plug in the power cord. Following table lists the fuses for the voltage used:

Center Voltage	Range	Fuse
100V	90V ~ 110V	3.15A Slow/250V
120V	108V ~ 132V	3.15A Slow/250V
220V	198V ~ 242V	1.6A Slow/250V
240V	216V ~ 250V	1.6A Slow/250V

The fuse should conform to the voltage used and replace it when the power cord is unplugged to avoid electric shock. When replacing the fuse, press the fuse holder inside the power socket then remove the existing fuse and insert the new one, then plug in the power cord.

 **CAUTION** Be sure to use correct fuse when changing it, or it may cause danger easily.

■ **This instrument operates in AC power source.**

If the power source is unstable in the range selected, it may cause the instrument to act abnormally or inaccurately. Please use appropriate equipment such as power regulator to convert it to applicable power source.

■ **This instrument uses the power transformer 200VA or above.**

If the tested device draws a great amount of current, it may flow in large current (about 10 Ampere) up to 10mS before the judgment of fail and output current cut off. The same situation may occur before performing the test. Thus it is necessary to pay attention to the capacity of power cord and the current line linked with other instruments and devices.

■ **Storage**

The normal temperature range is 18°C~28°C, ≤ 70% RH. The operation may incorrect if over the range. The storage temperature is -10°C~60°C, ≤ 80% RH. If you are not planning to use it for a long period of time, pack it with the original box for storage. For the sake of correct test and safety of this instrument, make sure not to store it in a place with direct sunlight or high temperature, also away from shaky, damp and dusty area.

■ **Warming up**

This instrument activates at power on; however, in order to meet the accuracy specified in the specification, please warm it up for 15 minutes or above.

■ **Warning Signal of Testing**

“DANGER – HIGH VOLTAGE TEST IN PROGRESS, UNAUTHORIZED PERSON KEEP AWAY”

■ **Keep test cable away from the panel**

Please keep the high voltage cable or the DUT away from the panel at least 30 cm during operation to avoid the display interference caused by high-voltage discharge.

### ■ Notices for connecting automated device

- The grounding system of the device and the automated station should be connected together.
- Add anti-interference iron core to the high voltage cable and the 2 ends (device output and DUT) of RTN/LOW test cable with winding at least 1 circle.
- The high voltage and RTN/LOW test cable must be separate from the control cable.
- The high voltage and RTN/LOW test cable must keep proper distance from the tester panel.

### ■ Standard warnings

#### **WARNING**

1. Only accessories that meet the manufacturer's specifications shall be used.
2. Do not disable the safety purpose of grounding type plug. Use the power supply cord only in combination with an earthed socket-outlet.
3. Do not block any ventilation openings to prevent over heating of the equipment. Keep the ventilation slits uncovered during operation. Failure to do so could cause the instrument to overheat and may damage internal components.
4. The mains plug is used as the disconnecting device and shall remain readily operable. The socket-outlet shall be installed near the equipment and shall be easily accessible.
5. If the instrument is used in a matter not specified by the manufacturer, the protection provided by the instrument may be impaired.
6. For European: A certified power supply cord not lighter than light PVC sheathed flexible cord according to IEC 60227, designation H03 VV-F or H03 VVH2-F (for equipment mass not exceeding 3 kg), or H05 VV-F or H05 VVH2-F2 (for equipment mass exceeding 3 kg), and be rated for at least 3G 0.75 mm<sup>2</sup> (for rated current up to 10 A) or 3G 1.0mm<sup>2</sup> (for rated current over 10 A up to 16 A) wire or larger, and the length of the cord does not exceed 2 m must be used.

## 3.2 Notices for Maintenance

Except notified in the manual there is no items can be maintained by user in this device.

Please contact Chroma or sales agent when any abnormal condition occurs in this device. Do not perform maintenance by yourself to avoid causing any unnecessary hazards that may damage the device.

## 3.3 Troubleshooting

Besides replacing the fuse (see section 3.1.3 *Solving Problems*) or other notified in the manual, there is no troubleshooting to be performed by user.

Please contact Chroma or sales agent when any abnormal condition occurs in this device. Do not perform maintenance by yourself to avoid causing any unnecessary hazards that may damage the device.

## **3.4 Input/Output Pin Assignment**

See the descriptions of front panel and rear panel in *Chapter 2*.

## 4. Calibration Procedure

Before performing this section the HiPot tester must warm up at least for 30 minutes. Take off the calibration label at the front panel and press the lock switch. After completed the calibration, please press the lock switch again for opening the hardware data backup protection circuit to avoid calibration data loss.

The following items are required for calibration.

### ■ Voltage Calibration (See section 4.2)

ACV 5KV Offset (0.05kV)	; AC HiPot Voltage Offset calibration (AC Mode)
ACV 5KV Full (4KV)	; AC HiPot Voltage Full calibration (AC Mode)
DCV 6KV Offset (0.05kV)	; DC HiPot Voltage Offset calibration (DC/IR Mode)
DCV 6KV Full (4KV)	; DC HiPot Voltage Full calibration (DC/IR Mode)
IRV 1KV Offset (0.05kV)	; IR Impedance Voltage Offset calibration (DC/IR Mode)
IRV 1KV Full (1kV)	; IR Impedance Voltage Full calibration (DC/IR Mode)

### ■ Current Calibration (See section 4.3)

ACA 3mA Offset (0.12mA)	; AC HiPot current 3mA range Offset calibration (AC Mode)
ACA 3mA Full (2.4mA)	; AC HiPot current 3mA range Full calibration (AC Mode)
ACA 20mA Offset (2.4mA)	; AC HiPot current 20mA range Offset calibration (AC Mode)
ACA 20mA Full (12mA)	; AC HiPot current 20mA range Full calibration (AC Mode)
DCA 3mA Offset (0.12mA)	; DC HiPot current 3mA range Offset calibration (DC/IR Mode)
DCA 3mA Full (2.4mA)	; DC HiPot current 3mA range Full calibration (DC/IR Mode)
DCA 5mA Offset (2.4mA)	; DC HiPot current 5mA range Offset calibration (DC/IR Mode)
DCA 5mA Full (4.8mA)	; DC HiPot current 5mA range Full calibration (DC/IR Mode)

### ■ ARcing Calibration (See section 4.4)

AC ARC 20mA (7mA)	; AC Withstanding Voltage ARcing calibration (AC Mode)
DC ARC 5mA (5mA)	; DC Withstanding Voltage ARcing calibration (DC Mode)

### ■ Insulation Resistance Calibration (See section 4.5)

IRR Range1 (1000M $\Omega$ )	; IR Resistor range 1 calibration (IR Mode)
IRR Range2 (100M $\Omega$ )	; IR Resistor range 2 calibration (IR Mode)
IRR Range3 (10M $\Omega$ )	; IR Resistor range 3 calibration (IR Mode)
IRR Range4 (10M $\Omega$ )	; IR Resistor range 4 calibration (IR Mode)

### ■ Ground Continue Calibration

GC 5 $\Omega$ Offset (1 $\Omega$ )	; GC 5 $\Omega$ offset calibration
GC 5 $\Omega$ Full (3 $\Omega$ )	; GC 5 $\Omega$ full calibration

### ■ LCD Contrast Calibration

CAL. CONTRAST (7)	; LCD contrast calibration
-------------------	----------------------------

## 4.1 Calibration

- Press [MENU].
- Press [UP] or [DOWN] to select "CALIBRATION".
- Press [SELECT].
- Press [A][A][A][B][ENTER].

## 4.2 Voltage Calibration

### 4.2.1 Connection Diagram

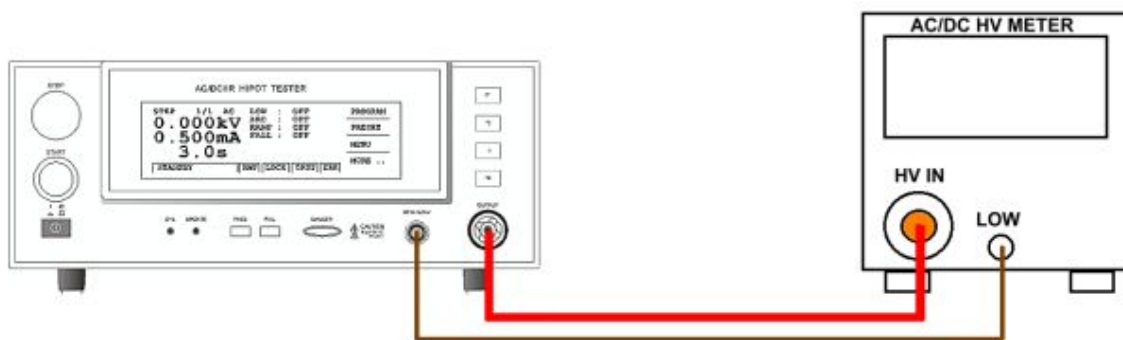

### 4.2.2 ACV Calibration (AC Mode)

- (1) Press [UP] or [DOWN] to select ACV offset calibration.
- (2) Connect an AC high voltage meter to HiPot tester.
- (3) Press [STOP][START]; reading the high voltage meter value, ex. 0.052kV.

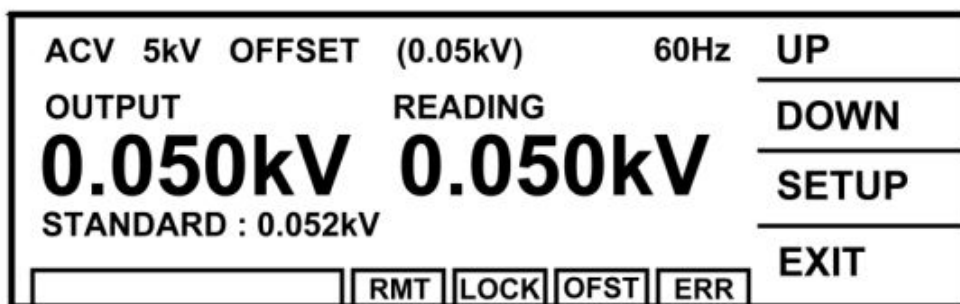

- (4) Press [INC.] or [DEC.] until the Standard Value display 0.052 kV and then press [ENTER] for saving.
- (5) Press [STOP] to stop ACV voltage offset calibration.
- (6) Press [UP] to change to the next calibration item.
- (7) Press [STOP][START] to read the high voltage meter value, ex. 4.052kV.

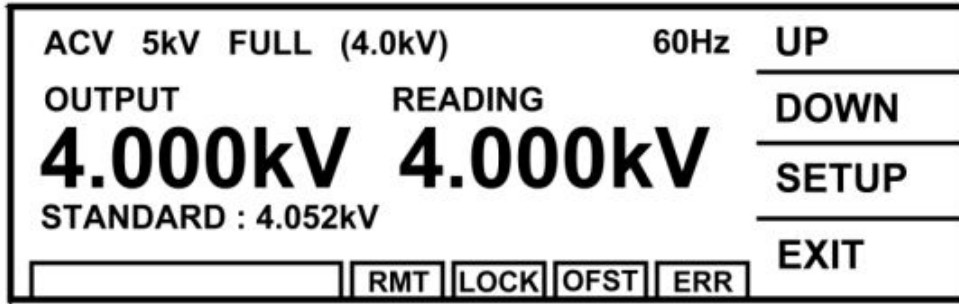

- (8) Press [INC.] or [DEC.] until shows 4.052 kV and press [ENTER] for saving.
- (9) Press [STOP] to stop ACV voltage full scale calibration.

### 4.2.3 DCV Calibration (DC/IR MODE)

- (1) Press [UP] or [DOWN] to select DCV offset calibration.
- (2) Connect a DC high voltage meter to HiPot tester.
- (3) Press [STOP][START] to read the high voltage meter value, ex. 0. 052kV.

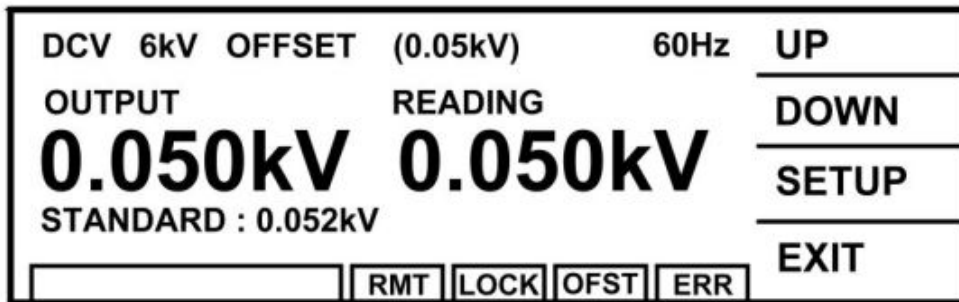

- (4) Press [INC.][DEC.] until shows 0.052kV and then press [ENTER] for saving.
- (5) Press [STOP] to stop DCV voltage offset calibration.
- (6) Press [UP] to change to the next calibration item.
- (7) Press [STOP][START] to read the high voltage meter value, ex. 4.052kV.



- (8) Press [INC.] or [DEC.] until shows 4.052 kV and then press [ENTER] for saving.
- (9) Press [STOP] to stop DCV voltage full scale calibration.

### 4.2.4 IRV Calibration (DC/IR Mode)

- (1) Press [UP] or [DOWN] to select IRV offset calibration.
- (2) Connect a DC high voltage meter to HiPot tester.
- (3) Press [STOP][START] to read the high voltage meter value, ex. 0.052kV.

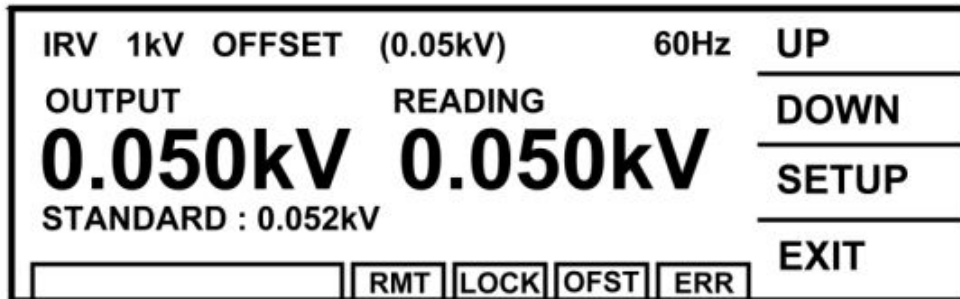

- (4) Press [INC.] or [DEC.] until shows 0.052 kV and then press [ENTER] for saving.
- (5) Press [STOP] to stop IR voltage offset calibration.
- (6) Press [UP] to change to the next calibration item.
- (7) Press [STOP][START] to read the high voltage meter value, ex. 1.052kV.

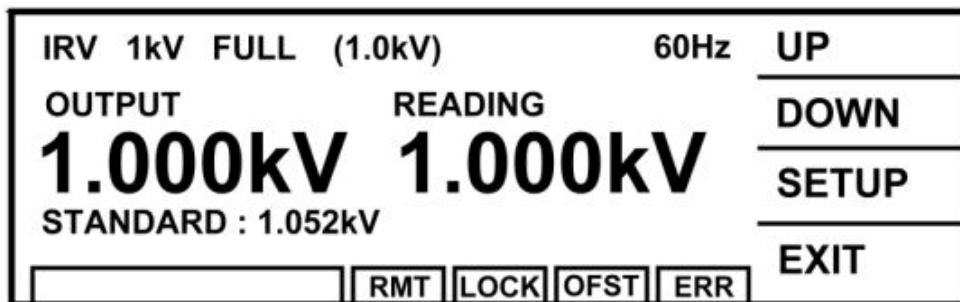

- (8) Press [INC.] or [DEC.] until shows 1.052 kV and then press [ENTER] for saving.
- (9) Press [STOP] to stop IR voltage full scale calibration.

## 4.3 Current Calibration

### 4.3.1 Connection Diagram

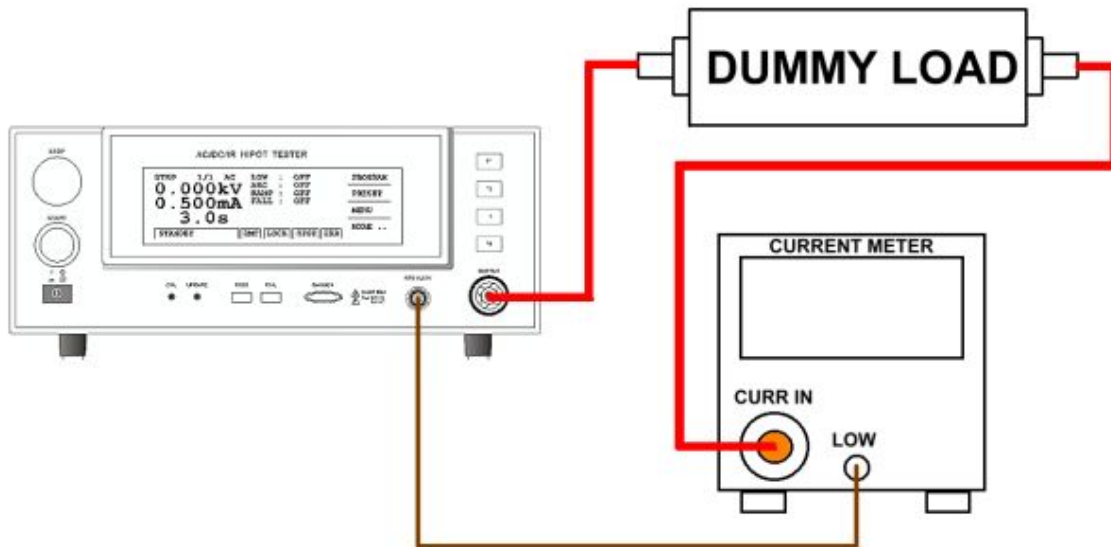

**⚡ CAUTION** : The dummy load connected to HiPot terminal contains high voltage. Be very careful with it as it may cause hazard.

### 4.3.2 ACA Calibration (AC MODE)

- Connect a dummy load resistor 10M $\Omega$ , 0.5 Watt or higher to the HiPot tester between high voltage output terminal and AC ammeter input high potential terminal. Connect the low potential terminal of HiPot tester to the low potential terminal of AC ammeter inputting.
  - (1) Press [UP] or [DOWN] to select ACA 3mA range offset calibration.
  - (2) Press [STOP][START] to read the ammeter value, ex. 0.124mA.



- (3) Press [INC.] or [DEC.] until shows 0.124mA and then press [ENTER] for saving.
- (4) Press [STOP] to stop ACA 3.0mA range offset calibration.
- (5) Press [UP] to change to the next calibration item.
- (6) Change the dummy load resistor to 500k $\Omega$  10watt or higher.
- (7) Press [STOP][START] to read the ammeter value, ex. 2.450mA.

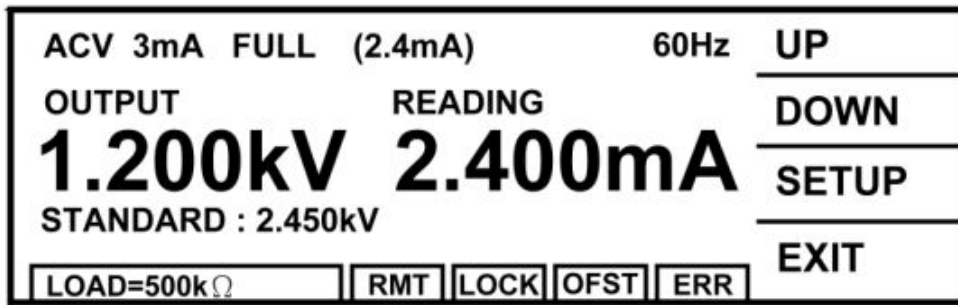

- (8) Press [INC.] or [DEC.] until shows 2.450mA and then press [ENTER] for saving.
- (9) Press [STOP] to stop ACA 3.0mA range full scale calibration.
- (10) Press [UP] to change to the next calibration item.
- (11) Press [STOP][START] to read the ammeter value, ex. 2.450mA.



- (12) Press [INC.] or [DEC.] until shows 2.450mA and then press [ENTER] for saving.
- (13) Press [STOP] to stop ACA 20.0mA range offset calibration.
- (14) Press [UP] to change to the next calibration item.
- (15) Change the dummy load resistor to 100kΩ 50watt or higher.
- (16) Press [STOP][START] to read the ammeter value, ex. 12.20mA.



- (17) Press [INC.] or [DEC.] until shows 12.20mA and then press [ENTER] for saving.
- (18) Press [STOP] to stop ACA 20.0mA range full scale calibration.

### 4.3.3 DCA Calibration (DC/IR MODE)

- Connect a dummy load resistor 10MΩ, 0.5 Watt or higher to HiPot tester between high voltage output terminal and DC ammeter input high potential terminal. Connect the low

potential terminal of HiPot tester to the low potential terminal of DC ammeter inputting.

- (1) Press [UP] or [DOWN] to select DCA 3mA range offset calibration.
- (2) Press [STOP][START] to read the ammeter value, ex. 0.124mA.



- (3) Press [INC.] or [DEC.] until shows 0.124mA and then press [ENTER] for saving.
- (4) Press [STOP] to stop DCA 3.0mA range offset calibration.
- (5) Press [UP] to change to the next calibration item.
- (6) Change the dummy load resistor to 500k $\Omega$  10watt or higher.
- (7) Press [STOP][START] to read the ammeter value, ex. 2.450mA.



- (8) Press [INC.] or [DEC.] until shows 2.450mA and then press [ENTER] for saving.
- (9) Press [STOP] to stop DCA 3.0mA range full scale calibration.
- (10) Press [UP] to change to the next calibration item.
- (11) Press [STOP][START] to read the ammeter value, ex. 2.45mA.



- (12) Press [INC.] or [DEC.] until shows 2.45mA and then press [ENTER] for saving.
- (13) Press [STOP] to stop DCA 5.0mA range offset calibration.
- (14) Press [UP] to change to the next calibration item.
- (15) Change the dummy load resistor to 250k $\Omega$  20watt or higher.

(16) Press [STOP][START] to read the ammeter value, ex. 4.85mA.

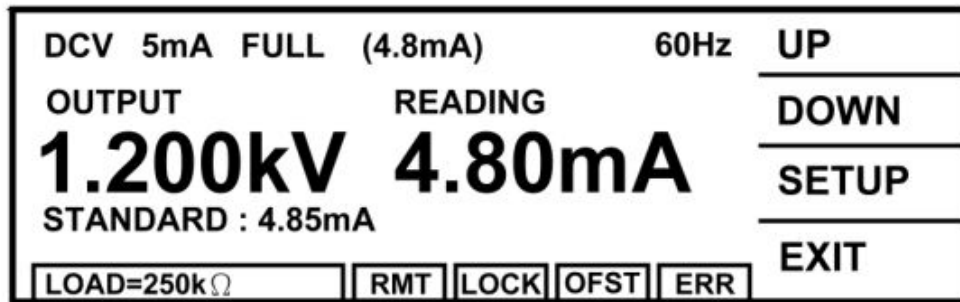

(17) Press [INC.] or [DEC.] until shows 4.85mA and then press [ENTER] for saving.

(18) Press [STOP] to stop DCA 5.0mA range full scale calibration.

## 4.4 ARC Calibration

### 4.4.1 Connection Diagram

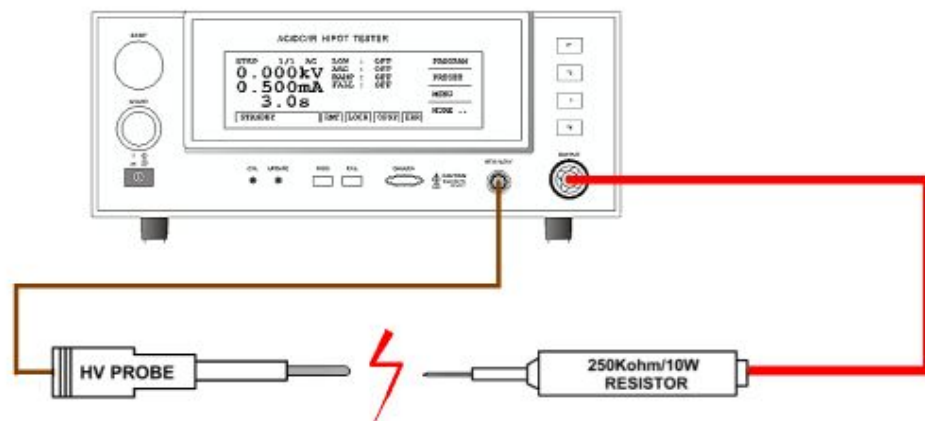

- ⚡ CAUTION**
1. ARC calibration is very special, the high voltage terminal are in outside. Be careful with it as it may cause hazard.
  2. Please contact your local agent for more detailed descriptions.

### 4.4.2 AC ARC Calibration (AC MODE)

- Connect one terminal of dummy load resistor 250kΩ, 5 Watt or higher to high voltage output terminal and get closer to low potential terminal of the HiPot tester gradually. However, do not connect the HiPot tester to another terminal of resistor and generate sparking between these two.

- (1) Press [UP] or [DOWN] to select AC ARC calibration.
- (2) Press [SETUP] [READING] to enter ARC reading setting.
- (3) Press [INC.] or [DEC.] until shows the reading is  $(\text{OUTPUT}/\text{READING}) \times 1.414$ ,  $((1.25\text{kV}/250\text{k}\Omega) \times 1.414) = 7.7\text{mA}$ .

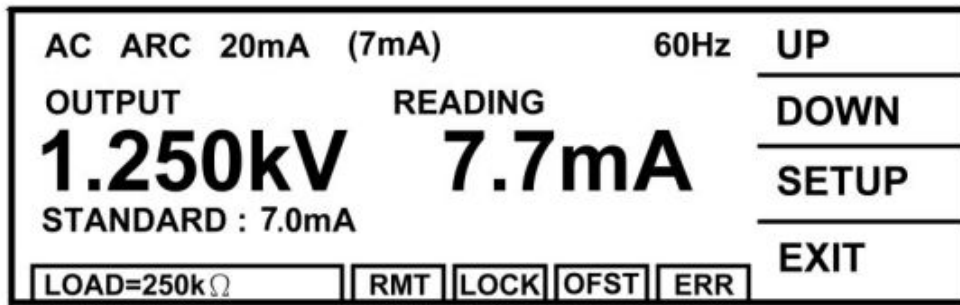

- (4) Press [RETURN] twice to exit ARC reading setting.
- (5) Press [STOP] [START] for starting test.
- (6) Press [INC.] or [DEC.] to adjust the low terminal of HiPot tester get closer to another terminal of the dummy load resistor gradually, and generate sparking between these two. The HiPot tester happens ARC fail.
- (7) Repeat step (5) – (6) until the sparking between these two is smaller, the HiPot tester still happens ARC fail.

#### 4.4.3 DC ARC Calibration (DC MODE)

- Connect one terminal of dummy load resistor 250k $\Omega$ , 5 Watt or higher to the high voltage output terminal and get closer to low potential terminal of the HiPot tester gradually. However, do not connect the HiPot tester to another terminal of resistor and generate sparking between these two.

- (1) Press [UP] or [DOWN] to select DC ARC calibration.
- (2) Press [SETUP] [READING] to enter ARC reading setting.
- (3) Press [INC.] or [DEC.] until shows the reading is (OUTPUT/READING), (0.75kV/250k $\Omega$ ) = 3mA.



- (4) Press [RETURN] twice to exit ARC reading setting.
- (5) Press [STOP] [START] for starting test.
- (6) Press [INC.] or [DEC.] to adjust the low terminal of HiPot tester get closer to another terminal of the dummy load resistor gradually, and generate sparking between these two. The HiPot tester happens ARC fail.
- (7) Repeat step (5) – (6) until the sparking between these two is smaller, the HiPot tester still happens ARC fail.

## 4.5 IRR Calibration (IR Mode)

### 4.5.1 Connection Diagram

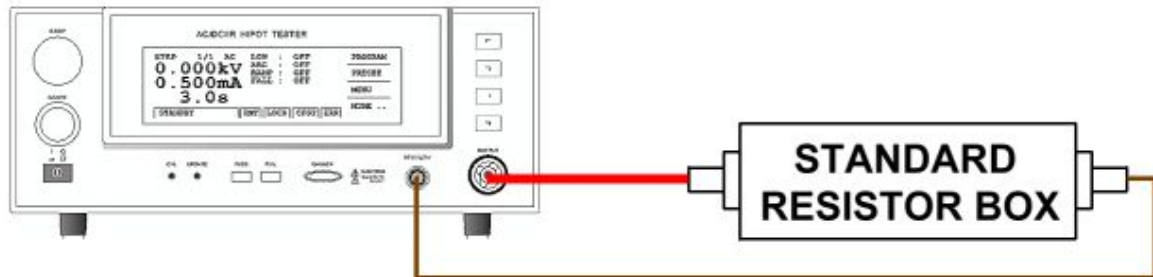

### 4.5.2 Insulation Resistance Calibration

- Connecting a standard dummy load resistor between the high voltage output terminal and low potential terminal of the Hi-Pot tester.

IRR Range1 (1000M $\Omega$ ) ; the dummy load resistor is 1000M $\Omega$ .  
 IRR Range2 (100M $\Omega$ ) ; the dummy load resistor is 100M $\Omega$ .  
 IRR Range3 (10M $\Omega$ ) ; the dummy load resistor is 10M $\Omega$ .  
 IRR Range4 (10M $\Omega$ ); the dummy load resistor is 10M $\Omega$ .

- (1) Press [UP] or [DOWN] to select IRR range 1 calibration.
- (2) To connect the standard dummy load resistor 1000M $\Omega$ .
- (3) Press [STOP] [START].
- (4) Press [INC.] or [DEC.] until shows the standard resistance value, ex. 1000M $\Omega$  and then press [ENTER] for saving.

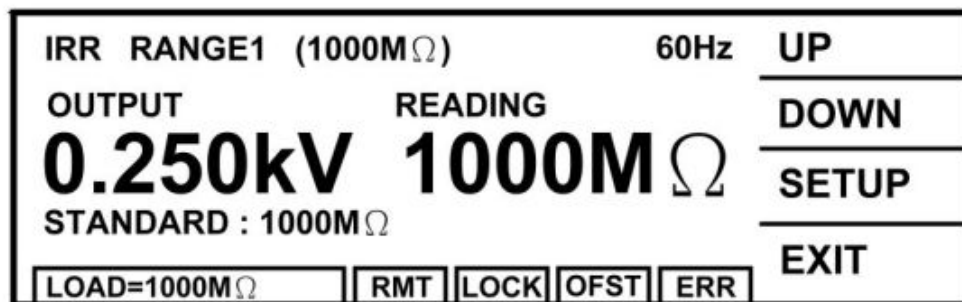

- (5) Press [STOP] to stop IRR range 1 calibration.
- (6) Press [UP] to change to the next calibration item.
- (7) Change the standard dummy load resistor to 100M $\Omega$ .
- (8) Press [STOP] [START].
- (9) Press [INC.] or [DEC.] until shows the standard resistance value, ex. 100M $\Omega$  and then press [ENTER] for saving.

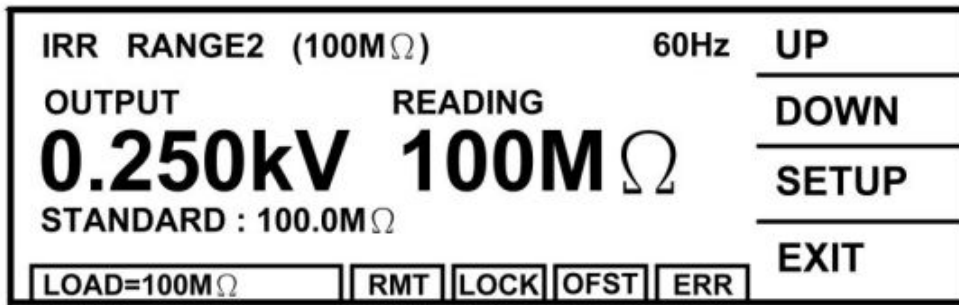

- (10) Press [STOP] to stop IRR range 2 calibration.
- (11) Press [UP] to change to the next calibration item.
- (12) Change the standard dummy load resistor to 10M $\Omega$ .
- (13) Press [STOP] [START].
- (14) Press [INC.] or [DEC.] until shows the standard resistance value, ex. 10M $\Omega$  and then press [ENTER] for saving.

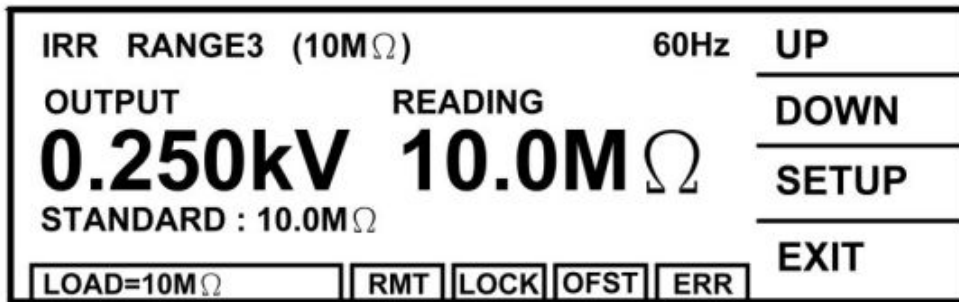

- (15) Press [STOP] to stop IRR range 3 calibration.
- (16) Press [UP] to change to the next calibration item.
- (17) Press [STOP] [START].
- (18) Press [INC.] or [DEC.] until shows the standard resistance value, ex. 10M $\Omega$  and then press [ENTER] for saving.

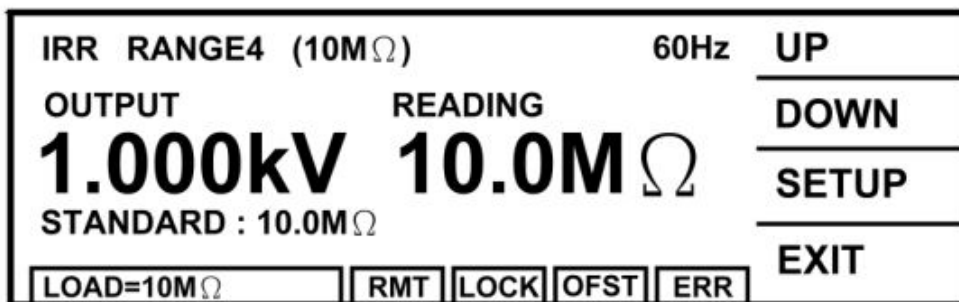

- (19) Press [STOP] to stop IRR range 4 calibration.

## 4.6 Ground Continue Calibration

### 4.6.1 Connection Diagram

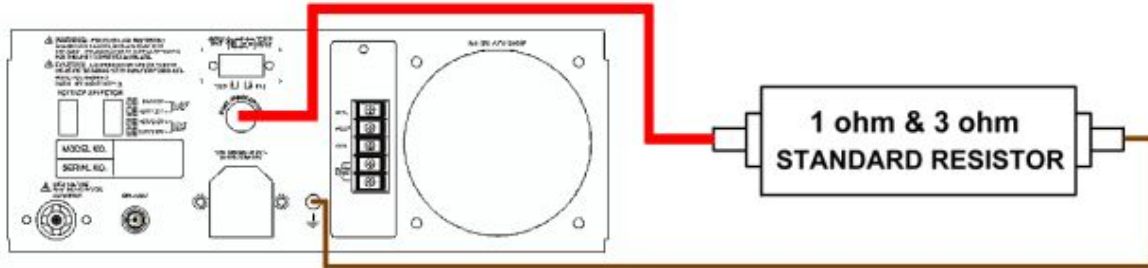

### 4.6.2 Description of Ground Continue Calibration

- Connect the standard dummy load resistor to the rear panel of HiPot tester which is between ground continue current output terminal and grounding terminal. Using the standard 1Ω and 3Ω 1/8 Watt dummy load resistors.

Prepare a standard 1Ω resistor

- (1) Press [UP].
- (2) Connect resistor to ground and CONT.CHK OPTION terminal of rear panel.
- (3) Press [STOP][START] to read GC resistance value 1Ω.
- (4) Press [UP] or [DOWN] until the reading is the actual resistance value.

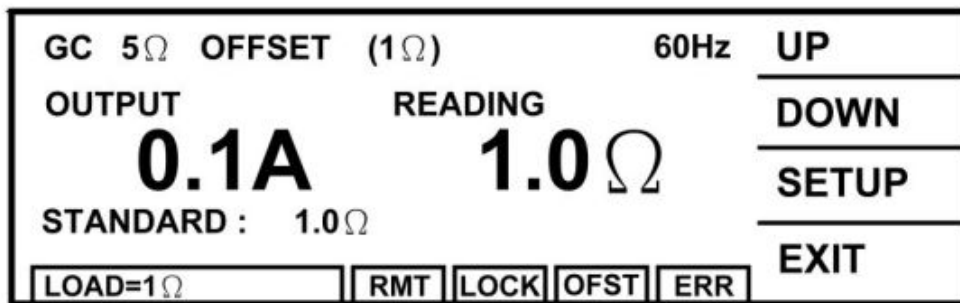

- (5) Press [ENTER] for saving the calibration value.
- (6) Press [STOP] to stop GC 5Ω Offset calibration.

Change the standard resistor to 3Ω.

- (1) Press [UP].
- (2) Connect resistor to ground and CONT.CHK OPTION terminal of rear panel.
- (3) Press [STOP][START] to read GC resistance value 3Ω.
- (4) Press [UP] or [DOWN] until the reading is the actual resistance value.

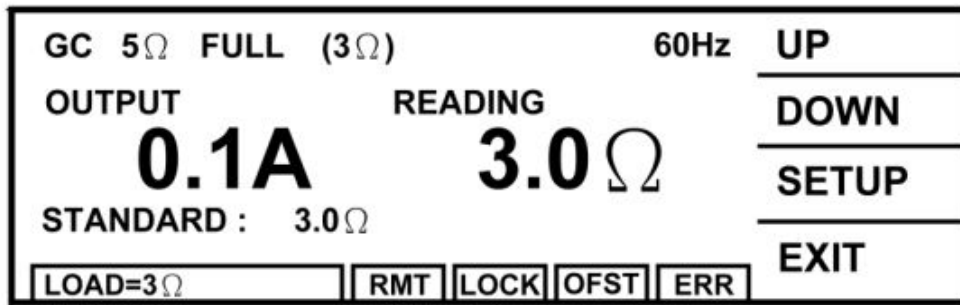

- (5) Press [ENTER] for saving the calibration value.
- (6) Press [STOP] to stop GC 5Ω Full calibration.

## 4.7 LCD Contrast Calibration

- After cleared the memory data, this calibration set LCD Contrast to the best suitable value.
- (1) Press [UP] or [DOWN] to select LCD Contrast Calibration.
  - (2) Press [SETUP] to enter LCD Contrast setting.
  - (3) Press [INC.] or [DEC.] until the reading shows the best suitable brightness.

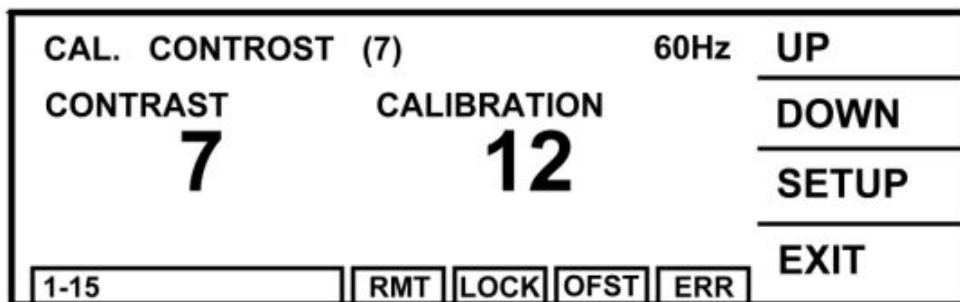

## 4.8 Complete Calibration

- Press [EXIT] to complete the calibration. Press the front panel calibration switch again for opening the hardware data backup protection circuit to avoid the calibration data loss.



## 5. RS485 Interface (For Link Model of 19073 + RS485)

If link model of 19073 + RS485 is purchased, please refer this chapter.

### 5.1 Description of Function

1. RS485 interface can connect multi-device, and it up to multi-device test synchronously through Master operation.

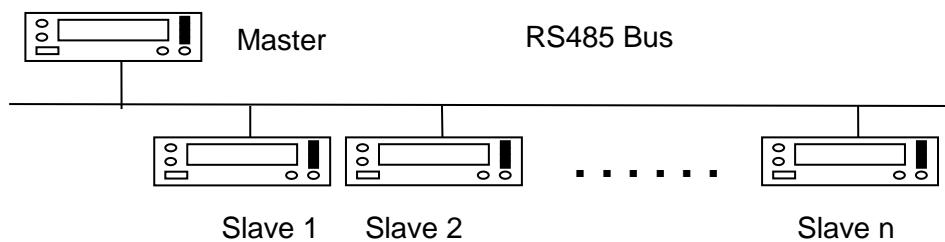

2. It is able to connect PC from this interface (PC includes RS485 interface). The PC is instead of Master for up to remote control function.

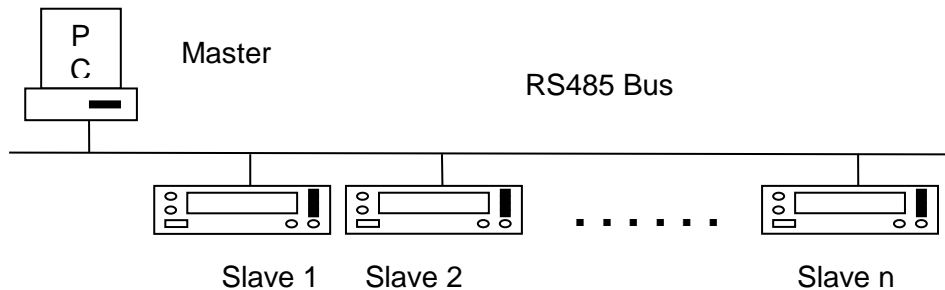

### 5.2 Parameter Setting

1. Press [MENU] under [STANDBY] screen, and by using [F1], [F2] to move the highlight to "OPTION" then press [SELECT]. Move the highlight to [REMOTE INTERFACE], press [SELECT] then can enter RS485 setting screen.
2. Use [NEXT] to move the highlight, and [UP], [DOWN] to switch the setting value.
3. Setting item descriptions:
  - a. INTERFACE: It selects if the RS485 interface existed or not.
  - b. UNIT TYPE: It selects the device is Master or Slave.
  - c. BAUD RATE: It selects the transmission rate is 4800, 9600 or 19200 baud rate.
  - d. SLAVE NUMBER (Master Only): When the tester is powered-on or test completed (selectable), Master will detect if address 1 to Slave communication is normal or not.
  - e. CHECK RESULT (Master Only): When CHECK RESULT ON, the rear panel signal meanings of Master are as the following:

UNDER TEST signal: It means Slave in testing.

PASS signal: It means all Slave connections are normal and the test completed.

FAIL signal: It means Slave not complete the test, may be the connections abnormal.

**Notice** When CHECK RESULT ON, Master will not judge the test result of the DUT, thus Master can't connect the DUT.

- SEND START (Master Only): It controls that Master receives [START] signal of front panel or rear panel, if it will send the signal to all Slaves through RS485 interface.

**Notice** When the tester power-on, before testing if Slave communication is normal, Master will switch Slave to Remote status in advance. When the test is completed, if this switch (SEND START) set as OFF then Master will switch Slave to Local status.

- UNIT ADDRESS (Slave Only): It sets Slave address, the range is 1-31 (Master address is fixed on 32).

## 5.3 Terminal and Pin Signal Connection

RS485

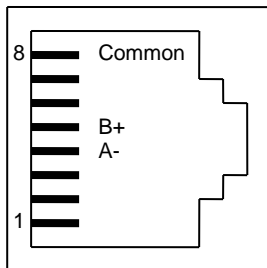
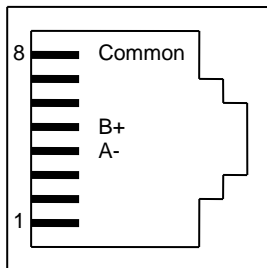

## 5.4 Communication Protocol

This interface uses half duplex of 2-wire system non-synchronized transmission mode.

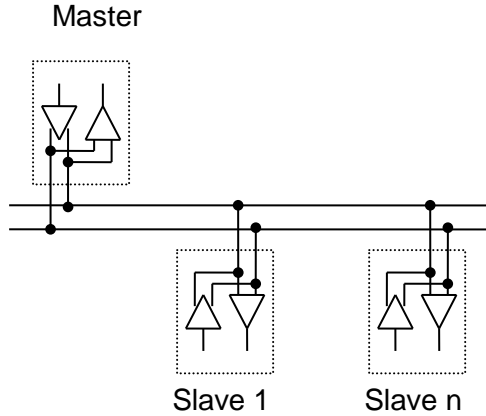

Before the bus control is transferred, please wait the time of two characters.

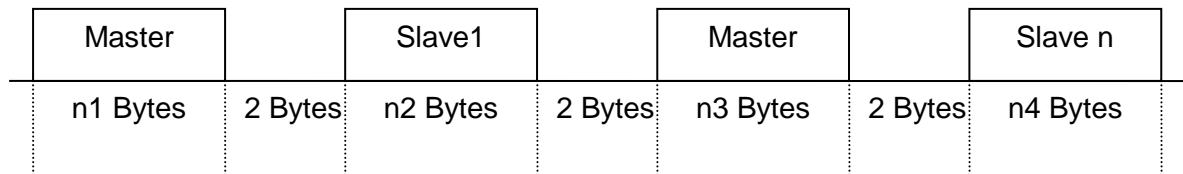

The transmission format of character is 1 initial bit, 8 data bits and 1 end bit, the total is 10 bits.

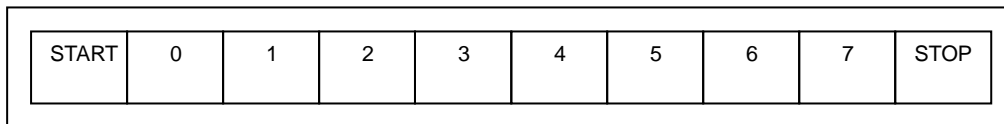

The receivers don't respond any data under broadcast mode. When the receivers receive the query functions under node-to-node transmission mode, it returns the relative data. However, the receivers receive the execution command, it returns the result of executing. About Reply Message, please refer the descriptions of command.

The commands are packed into packets, Data Frame as the following:

Header	DA	SA	Length	Data Field	Checksum
1 byte	1 byte	1 byte	1 byte	n bytes	1 byte

Header: 0xAB  
 Destination Address: 0x0 ~ 0x7F, 0xFF is broadcast address  
 Source Address: 0x0 ~ 0x7F  
 Data Field Length: It means the length of data field.  
 Data Field: Please refer the command set.

Command Code	Parameter
1 byte	0 ~ n-1 bytes

Checksum: Summing these values into two's complements, included data are DA + SA + Length + Data Field

## 5.5 Command List

Commands	Code (Hex)
*IDN?	0x90
Display Address	0x20
Stop	0x21
Start	0x22
Offset Get/Off	0x23
Offset?	0xA3
Step Parameters	0x24
Step Parameters?	0xA4
Preset Parameters	0x25
Preset Parameters	0xA5
Store Memory	0x26
Recall Memory	0x27
Delete Memory	0x28
System Setting	0x29
System Setting?	0xA9
Key Lock	0x2A
Key Lock?	0xAA
Initialize All Steps Parameters	0x2C
Step Number?	0xAD
Remote/Local	0x2E
Remote?	0xAE
Set C Standard	0x2F
Result?	0xB1
Do Get C Standard	0x33
Reply Message	0x7F

## 5.6 Command Description

### \*IDN?

---

Description: It queries the devices' identification and describes the string.  
 Command code: 0x90  
 Parameter: None  
 Return data: The format is "Company Name, Device Name, Device S/N, Firmware Version, Hold Field"

#### Example:

Master (0x70): 0xAB 0x01 0x70 0x01 0x90 0xFE

Slave (0x01): 0xAB 0x70 0x01 0x16 0x90 0x43 0x48 0x52 0x4F 0x4D 0x41 0x2C  
 0x31 0x39 0x30 0x37 0x33 0x2C 0x30 0x2C 0x33 0x2E 0x31 0x31  
 0x2C 0x30 0x58

#### Descriptions of example

The setting meanings of HEX inputs are as the following:

0xAB = Header

0x01 = Destination Address

0x70 = Source Address

0x01 = Data Field Length

0x90 = Command Code

0xFE = Checksum

The reading meanings of returning HEX code are as the following:

0xAB = Header  
 0x70 = Destination Address  
 0x01 = Source Address  
 0x16 = Data Field Length  
 0x90 = Command Code  
 0x43 0x48 0x52 0x4F 0x4E 0x4D 0x41 = "CHROMA" Company Name (return data)  
 0x2C = "," (return data)  
 0x31 0x39 0x30 0x37 0x33 = "19073" Device Name (return data)  
 0x2C = "," (return data)  
 0x30 = "0" Device S/N (return data)  
 0x2C = "," (return data)  
 0x33 0x2E 0x31 0x31 = "3.11" Firmware Version (return data)  
 0x2C = " ," (return data)  
 0x30 = "0" Hold Field (return data)  
 0x58 = Checksum

### Display Address

---

Description: It displays the device address.  
 Command code: 0x20  
 Parameter: None  
 Return data: Reply Message  
 Example: Master (0x70): 0xAB 0x01 0x70 0x01 0x20 0x6E  
 Slave (0x01): 0xAB 0x70 0x01 0x02 0x7F 0x00 0x0E

### Descriptions of example

The setting meanings of HEX inputs are as the following:

0xAB = Header  
 0x01 = Destination Address  
 0x70 = Source Address  
 0x01 = Source Address  
 0x20 = Command Code  
 0x6E = Checksum

The reading meanings of returning HEX code are as the following:

0xAB = Header  
 0x70 = Destination Address  
 0x01 = Source Address  
 0x02 = Source Address  
 0x7F = Reply Message Command Code  
 0x00 = Reply Message Return Data  
 0x0E = Checksum

### Stop

---

Description: Stop test  
 Command code: 0x21  
 Parameter: None  
 Return data: Reply Message  
 Example: Master (0x70): 0xAB 0x01 0x70 0x01 0x21 0x6D  
 Slave (0x01): 0xAB 0x70 0x01 0x02 0x7F 0x00 0x0E

### Descriptions of example

The setting meanings of HEX inputs are as the following:

0xAB = Header  
0x01 = Destination Address  
0x70 = Source Address  
0x01 = Data Field Length  
0x21 = Command Code  
0x6D = Checksum

The reading meanings of returning HEX code are as the following:

0xAB = Header  
0x70 = Destination Address  
0x01 = Source Address  
0x02 = Data Field Length  
0x7F = Reply Message Command Code  
0x00 = Reply Message Return Data  
0x0E = Checksum

### Start

---

Description: Start test  
Command code: 0x22  
Parameter: None  
Return data: Reply Message  
Example: Master (0x70): 0xAB 0x01 0x70 0x01 0x22 0x6C  
Slave (0x01): 0xAB 0x70 0x01 0x02 0x7F 0x00 0x0E

### Descriptions of example

The setting meanings of HEX inputs are as the following:

0xAB = Header  
0x01 = Destination Address  
0x70 = Source Address  
0x01 = Data Field Length  
0x22 = Command Code  
0x6C = Checksum

The reading meanings of returning HEX code are as the following:

0xAB = Header  
0x70 = Destination Address  
0x01 = Source Address  
0x02 = Data Field Length  
0x7F = Reply Message Command Code  
0x00 = Reply Message Return Data  
0x0E = Checksum

### Offset Get/Off

---

Description: It switches OFFSET status.  
Command code: 0x23  
Parameter: 1 byte, 0:OFF or 2:GET  
Return data: Reply Message  
Example: Master (0x70): 0xAB 0x01 0x70 0x02 0x23 0x02 0x68  
Slave (0x01): 0xAB 0x70 0x01 0x02 0x7F 0x00 0x0E

### Descriptions of example

The setting meanings of HEX inputs are as the following:

0xAB = Header  
0x01 = Destination Address  
0x70 = Source Address  
0x02 = Data Field Length  
0x23 = Command Code  
0x02 = 2:GET (Command Parameter)  
0x68 = Checksum

The reading meanings of returning HEX code are as the following:

0xAB = Header  
0x70 = Destination Address  
0x01 = Source Address  
0x02 = Data Field Length  
0x7F = Reply Message Command Code  
0x00 = Reply Message Return Data  
0x0E = Checksum

### Offset?

---

Description: It queries OFFSET status.  
Command code: 0xA3  
Parameter: None  
Return data: 1 byte, 0: Off, 1:On or 2:Getting  
Example: Master (0x70):0xAB 0x01 0x70 0x01 0xA3 0xEB  
Slave (0x01): 0xAB 0x70 0x01 0x02 0xA3 0x00 0xEA

### Descriptions of example

The setting meanings of HEX inputs are as the following:

0xAB = Header  
0x01 = Destination Address  
0x70 = Source Address  
0x01 = Data Field Length  
0xA3 = Command Code  
0xEB = Checksum

The reading meanings of returning HEX code are as the following:

0xAB = Header  
0x70 = Destination Address  
0x01 = Source Address  
0x02 = Data Field Length  
0xA3 = Command Code  
0x00 = 0: Off (Return Data)  
0xEA = Checksum

### Step Parameters

---

Description: It sets all parameters of various steps.  
Command code: 0x24  
Parameter: 28 bytes

**AC mode**

Name	Size (byte)	Unit	Range	Description
Step index	1	-	1~10	Must less or equal original step number + 1
Mode	1	-	1	AC mode
Source	2	V	0, 50~5000	0:OFF
Ramp Time	2	100mS	0~9990	0:OFF
Reserved	2	-	0	Reserved
Test Time	2	100mS	0~9990	0:Continue
Fall Time	2	100mS	0~9990	0:OFF
High Limit	4	100nA	10~200000 10~30000	The max. is 200000 when EN50191 is OFF. The max. is 30000 when EN50191 is ON.
Low Limit	4	100nA	0, 10~200000 10~30000	0:OFF The max. is 200000 when EN50191 is OFF. The max. is 30000 when EN50191 is ON.
Arc Limit	4	100nA	0, 10000~200000	0:OFF
Reserved	4	-	0	Reserved

**DC Mode**

Name	Size (byte)	Unit	Range	Description
Step index	1	-	1~10	Must less or equal original step number + 1
Mode	1	-	2	DC mode
Source	2	V	0, 50~6000	
Ramp Time	2	100mS	0~9990	0:OFF
Dwell Time	2	100mS	0~9990	0:OFF
Test Time	2	100mS	0~9990	0:Continue
Fall Time	2	100mS	0~9990	0:OFF
High Limit	4	100nA	1~50000	
Low Limit	4	100nA	0~50000	0:OFF
Arc Limit	4	100nA	0, 10000~50000	0:OFF
Inrush	4	-	0/10000	0:OFF, 10000:ON

**IR Mode**

Name	Size (byte)	Unit	Range	Description
Step index	1	-	1~10	Must less or equal original step number + 1
Mode	1	-	3	IR mode
Source	2	V	0, 50~1000	
Ramp Time	2	100mS	0~9990	0:OFF
Dwell Time	2	100mS	0~9990	0:OFF
Test Time	2	100mS	0, 3~9990	0:Continue
Fall Time	2	100mS	0~9990	0:OFF
High Limit	4	100kOhm	0~500000	0:OFF
Low Limit	4	100kOhm	1~500000	
IR Range	4	-	0~6	0: 300nA, 1: 3uA, 2: 30uA, 3: 300uA, 4: 3mA, 5: 5mA, 6: Auto Range
Reserved	4	-	0	Reserved

**GC Mode**

Name	Size (byte)	Unit	Range	Description
Step index	1	-	1~10	Must less or equal original step number + 1
Mode	1	-	4	GC mode
Source	2	100mA	0/1	
Reserved	2	-	0	Reserved
Dwell Time	2	100mS	1~10	
Reserved	2	-	0	Reserved
Reserved	2	-	0	Reserved
High Limit	4	100mOhm	1~50	
Low Limit	4	100mOhm	0~50	0:OFF

Reserved	4	-	0	Reserved
Reserved	4	-	0	Reserved

**PA Mode (Pause mode)**

Name	Size (byte)	Unit	Range	Description
Step index	1	-	1~10	Must less or equal original step number + 1
Mode	1	-	5	PA mode
UT Signal	2	-	1 or 2	(Under Test Signal) 1:Off, 2:On
Message	16	-		C String, maximum length is 15
Reserved	4	-	0	Reserved
Reserved	4	-	0	Reserved

**OS Mode (OSC mode)**

Name	Size (byte)	Unit	Range	Description
Step index	1	-	1~10	Must less or equal original step number + 1
Mode	1	-	6	OS mode
Source	2	V	100	Always 100V
Open Limit	2	10%	1~10	10% ~ 100%
Reserved	2	-	0	Reserved
Test Time	2	100mS	1	Always 100mS
Short Limit	2	100%	0, 1~5	OFF, 100% ~ 500%
C Standard	4	pF	0~25100 0~5000	When Short Limit is OFF, Max. is 25100. When Short Limit is not OFF, Max. is 5000.
Reserved	4	-	0	Reserved
Range	4	-	1~3	3 is maximum range
Reserved	4	-	0	Reserved

Return data: Reply Message

Example: Master (0x70): 0xAB 0x01 0x70 0x1D 0x24 0x01 0x01 0xE8 0x03  
0x14 0x00 0x00 0x00 0x32 0x00 0x1E 0x00 0x10 0x27 0x00 0x00  
0xE8 0x03 0x00 0x00 0x10 0x27 0x00 0x00 0x00 0x00 0x00 0x00  
0xA4  
Slave (0x01): 0xAB 0x70 0x01 0x02 0x7F 0x00 0x0E

- Remark:
1. When the length of data is larger than 1 character (byte), it is needed to send the minimum character in advance.
  2. When the message of PA mode is lowercase character, it will change to uppercase character automatically.
  3. The inputted various parameters will round off automatically then save to memory as needed.

**Descriptions of example**

The setting meanings of HEX inputs are as the following:

0xAB = Header

0x01 = Destination Address

0x70 = Source Address

0x1D = Data Field Length

0x24 = Command Code

0x01 = Step1 (Command Parameter)

0x01 = AC Mode (Command Parameter)

0xE8 0x03 = Voltage 1000V (Command Parameter)

0x14 0x00 = Ramp Time 2sec (Command Parameter)

0x00 0x00 = Reserved (Command Parameter)

0x32 0x00 = Test Time 5sec (Command Parameter)

0x1E 0x00 = fall time 3sec (Command Parameter)

0x10 0x27 0x00 0x00 = Hi Limit 1.000mA (Command Parameter)

0xE8 0x03 0x00 0x00 = Low Limit 0.100mA (Command Parameter)  
0x10 0x27 0x00 0x00 = Arc Limit 1.000mA (Command Parameter)  
0x00 0x00 0x00 0x00 = Reserved (Command Parameter)  
0xA4 = Checksum

The reading meanings of returning HEX code are as the following:

0xAB = Header  
0x70 = Destination Address  
0x01 = Source Address  
0x02 = Data Field Length  
0x7F = Reply Message Command Code  
0x00 = Reply Message Return Data  
0x0E = Checksum

### Step Parameters?

---

Description: It queries all parameters of various steps.

Command code: 0xA4

Parameter: 1 byte, the serial number of step, the range is 1-10

Return data: 28 bytes data

Example: Master (0x70): 0xAB 0x01 0x70 0x02 0xA4 0x01 0xE8

Slave (0x01): 0xAB 0x70 0x01 0x1D 0xA4 0x01 0x01 0x38 0x04  
0x1E 0x00 0x00 0x00 0x3C 0x00 0x09 0x00 0x0C  
0x17 0x00 0x00 0x90 0x01 0x00 0x00 0x20 0x4E  
0x00 0x00 0x00 0x00 0x00 0x00 0x0B

### Descriptions of example

The setting meanings of HEX inputs are as the following:

0xAB = Header  
0x01 = Destination Address  
0x70 = Source Address  
0x02 = Data Field Length  
0xA4 = Command Code  
0x01 = Parameter  
0xE8 = Checksum

The reading meanings of returning HEX code are as the following:

0xAB = Header  
0x70 = Destination Address  
0x01 = Source Address  
0x1D = Data Field Length  
0xA4 = Command Code  
0x01 = Step1 (Return Data)  
0x01 = AC Mode (Return Data)  
0x38 0xE4 = Voltage 1080V (Return Data)  
0x1E 0x00 = Ramp Time 3sec (Return Data)  
0x00 0x00 = Reserved (Return Data)  
0x3C 0x00 = Test Time 6sec (Return Data)  
0x09 0x00 = Fall Time 0.9sec (Return Data)  
0x0C 0x17 0x00 0x00 = Hi Limit 0.590mA (Return Data)  
0x90 0x01 0x00 0x00 = Low Limit 0.040mA (Return Data)  
0x20 0x4E 0x00 0x00 = Arc Limit 2.000mA (Return Data)  
0x00 0x00 0x00 0x00 = Reserved (Return Data)  
0x0B = Checksum

## Preset Parameters

Description: It sets all parameters of Preset.

Command code: 0x25

Parameter: 6 bytes

Name	Size (byte)	Unit	Range	Description
AC Frequency	1	Hz	50/60	
Software AGC	1	-	0/1	0:OFF, 1:ON
WV Auto Range	1	-	0/1	0:OFF, 1:ON
IR Auto Range	1	-	0/1	0:OFF, 1:ON
GFI(Ground Fault Interrupt)	1	-	0/1	0:OFF, 1:ON
Fail Restart	1	-	0/1	0:OFF, 1:ON
Screen	1	-	0/1	0:OFF, 1:ON

Return data: Reply Message

Example: Master (0x70): 0xAB 0x01 0x70 0x08 0x25 0x32 0x00 0x01 0x00 0x01  
0x01 0x00 0x2D  
Slave (0x01): 0xAB 0x70 0x01 0x02 0x7F 0x00 0x0E

### Descriptions of example

The setting meanings of HEX inputs are as the following:

0xAB = Header

0x01 = Destination Address

0x70 = Source Address

0x08 = Data Field Length

0x25 = Command Code

0x32 = ACV Frequency 50Hz

0x00 = Software AGC OFF

0x01 = WV Auto Range ON

0x00 = IR Auto Range OFF

0x01 = Ground Fault Interrupt (GFI) ON

0x01 = Fail Restart ON

0x00 = Screen OFF

0x2D = Checksum

The reading meanings of returning HEX code are as the following:

0xAB = Header

0x70 = Destination Address

0x01 = Source Address

0x02 = Data Field Length

0x7F = Reply Message Command Code

0x00 = Reply Message Return Data

0x0E = Checksum

## Preset Parameter?

Description: It queries all parameters of Preset.

Command code: 0xA5

Parameter: None

Return data: 6 bytes

Example: Master (0x70): 0xAB 0x01 0x70 0x01 0xA5 0xE9  
Slave (0x01): 0xAB 0x70 0x01 0x08 0xA5 0x3C 0x01 0x00 0x01 0x01  
0x00 0x01 0xA2

### Descriptions of example

The setting meanings of HEX inputs are as the following:

0xAB = Header  
0x01 = Destination Address  
0x70 = Source Address  
0x01 = Data Field Length  
0xA5 = Data Field Length  
0xE9 = Checksum

The reading meanings of returning HEX code are as the following:

0xAB = Header  
0x70 = Destination Address  
0x01 = Source Address  
0x07 = Data Field Length  
0xA5 = Command Code  
0x3C = ACV Frequency 60Hz (Return Data)  
0x01 = Software AGC ON (Return Data)  
0x00 = WV Auto Range OFF (Return Data)  
0x01 = IR Auto Range ON (Return Data)  
0x01 = Ground Fault Interrupt (GFI) ON  
0x00 = Fail Restart OFF (Return Data)  
0x01 = Screen ON  
0xA2 = Checksum

### Store Memory

---

Description: It saves the parameters of various steps and Preset to the internal memory.

Command code: 0x26

Parameter: Serial number of memory + Name of memory. The length of serial number of memory is 1 character. The range is 1 ~ 60, the name length of the memory is 0 ~ 10 character.

Return data: Reply Message

Example: Master (0x70): 0xAB 0x01 0x70 0x08 0x26 0x01 0x43 0x48 0x52 0x4F  
0x4D 0x41 0xA6

Slave (0x01): 0xAB 0x70 0x01 0x02 0x7F 0x00 0x0E

Remark: When the name of memory is lowercase character, it will change to uppercase character automatically.

### Descriptions of example

The setting meanings of HEX inputs are as the following:

0xAB = Header  
0x01 = Destination Address  
0x70 = Source Address  
0x08 = Data Field Length (Length of memory name is 6)  
0x26 = Command Code  
0x01 = Memory S/N

0x43 0x48 0x52 0x4F 0x4D 0x41 = "CHROMA" Memory Name  
(Command Parameter)

0xA6 = Checksum

The reading meanings of returning HEX code are as the following:

0xAB = Header

0x70 = Destination Address  
0x01 = Source Address  
0x02 = Data Field Length  
0x7F = Reply Message Command Code  
0x00 = Reply Message Return Data  
0x0E = Checksum

## Recall Memory

---

Description: It recalls the saved test steps from various device internal memories.  
Command code: 0x27  
Parameter: 1 byte, serial number of memory, the range is 1 ~ 60  
Return data: Reply Message  
Example: Master (0x70): 0xAB 0x01 0x70 0x02 0x27 0x01 0x65  
Slave (0x01): 0xAB 0x70 0x01 0x02 0x7F 0x00 0x0E

### Descriptions of example

The setting meanings of HEX inputs are as the following:

0xAB = Header  
0x01 = Destination Address  
0x70 = Source Address  
0x02 = Data Field Length  
0x27 = Command Code  
0x01 = "01" Memory S/N (Command Parameter)  
0x65 = Checksum

The reading meanings of returning HEX code are as the following:

0xAB = Header  
0x70 = Destination Address  
0x01 = Source Address  
0x02 = Data Field Length  
0x7F = Reply Message Command Code  
0x00 = Reply Message Return Data  
0x0E = Checksum

## Delete Memory

---

Description: It deletes the saved test steps from the memories inside device.  
Command code: 0x28  
Parameter: 1 byte, serial number of memory, the range is 0 ~ 60. When the parameter is 0, it means it is need to clear the working memory, this includes all steps and Preset parameters.  
Return data: Reply Message  
Example: Master (0x70): 0xAB 0x01 0x70 0x02 0x28 0x01 0x64  
Slave (0x01): 0xAB 0x70 0x01 0x02 0x7F 0x00 0x0E

### Descriptions of example

The setting meanings of HEX inputs are as the following:

0xAB = Header  
0x01 = Destination Address  
0x70 = Source Address  
0x02 = Data Field Length  
0x28 = Command Code  
0x01 = "01" Memory S/N (Command Parameter)  
0x64 = Checksum

The reading meanings of returning HEX code are as the following:

- 0xAB = Header
- 0x70 = Destination Address
- 0x01 = Source Address
- 0x02 = Data Field Length
- 0x7F = Reply Message Command Code
- 0x00 = Reply Message Return Data
- 0x0E = Checksum

## System Setting

Description: It sets the system parameter.

Command code: 0x29

Parameter: 4 bytes

Name	Size (byte)	Unit	Range	Description
Contrast	1	-	1~15	
Buzzer Volume	1	-	0/1/2/3	0:OFF, 1:Low, 2:Medium, 3:High
EN50191	1	-	0/1	0:OFF, 1:ON (AC maximum is 3mA)
DC 50V AGC	1	-	0/1	0:OFF, 1:ON
Pass On	1	100mS	0 ~ 100	0:OFF
END OF STEP	1	-	0/1	0:OFF, 1:ON
EOT	1	-	0/1	0:END OF TEST, 1:END OF TIMER

Return data: Reply Message

Example: Master (0x70): 0xAB 0x01 0x70 0x08 0x29 0x0A 0x03 0x00 0x00 0x00  
0x00 0x01 0x50

Slave (0x01): 0xAB 0x70 0x01 0x02 0x7F 0x00 0x0E

### Descriptions of example

The setting meanings of HEX inputs are as the following:

- 0xAB = Header
- 0x01 = Destination Address
- 0x70 = Source Address
- 0x08 = Data Field Length
- 0x29 = Command Code
- 0x0A = Contrast 10 (Command Parameter)
- 0x03 = Buzzer Volume High (Command Parameter)
- 0x00 = EN50191 OFF (Command Parameter)
- 0x00 = DC 50V AGC OFF (Command Parameter)
- 0x00 = PASS ON OFF (Command Parameter)
- 0x00 = END OF STEP OFF (Command Parameter)
- 0x01 = END OF TIMER (Command Parameter)
- 0x50 = Checksum

The reading meanings of returning HEX code are as the following:

- 0xAB = Header
- 0x70 = Destination Address
- 0x01 = Source Address
- 0x02 = Data Field Length
- 0x7F = Reply Message Command Code
- 0x00 = Reply Message Return Data

0x0E = Checksum

## System Setting?

---

Description: It queries the system parameter.

Command code: 0xA9

Parameter: None

Return data: 7 bytes

Example:

Master (0x70): 0xAB 0x01 0x70 0x01 0xA9 0xE5

Slave (0x01): 0xAB 0x70 0x01 0x08 0xA9 0x08 0x01 0x01 0x01 0x00 0x00 0x01  
0xD2

### Descriptions of example

The setting meanings of HEX inputs are as the following:

0xAB = Header

0x01 = Destination Address

0x70 = Source Address

0x01 = Data Field Length

0xA9 = Command Code

0xE5 = Checksum

The reading meanings of returning HEX code are as the following:

0xAB = Header

0x70 = Destination Address

0x01 = Source Address

0x08 = Data Field Length

0xA9 = Command Code

0x08 = Contrast 8 (Return Data)

0x01 = Buzzer Volume Low (Return Data)

0x01 = EN50191 ON (Return Data)

0x01 = DC 50V AGC ON (Return Data)

0x00 = PASS ON OFF (Command Parameter)

0x00 = END OF STEP OFF (Command Parameter)

0x01 = END OF TIMER (Command Parameter)

0xD2 = Checksum

## Key Lock

---

Description: It switches KEY LOCK status.

Command code: 0x2A

Parameter: 1 byte

0: key board lock OFF, recall key lock OFF

1: key board lock ON, recall key lock OFF

2: key board lock ON, recall key lock ON

Return data: Reply Message

Example: Master (0x70): 0xAB 0x01 0x70 0x02 0x2A 0x01 0x62

Slave (0x01): 0xAB 0x70 0x01 0x02 0x7F 0x00 0x0E

### Descriptions of example

The setting meanings of HEX inputs are as the following:

0xAB = Header

0x01 = Destination Address

0x70 = Source Address

0x02 = Data Field Length

0x2A = Command Code  
0x01 = "01"key board lock ON, recall key lock (Command Parameter)  
0x62 = Checksum

The reading meanings of returning HEX code are as the following:

0xAB = Header  
0x70 = Destination Address  
0x01 = Source Address  
0x02 = Data Field Length  
0x7F = Reply Message Command Code  
0x00 = Reply Message Return Data  
0x0E = Checksum

### Key Lock?

---

Description: It queries KEY LOCK status.

Command code: 0xAA

Parameter: None

Return data: 1 byte data

0: key board lock OFF, recall key lock OFF

1: key board lock ON, recall key lock OFF

2: key board lock ON, recall key lock ON

Example: Master (0x70): 0xAB 0x01 0x70 0x01 0xAA 0xE4

Slave (0x01): 0xAB 0x70 0x01 0x02 0xAA 0x01 0xE2

### Descriptions of example

The setting meanings of HEX inputs are as the following:

0xAB = Header  
0x01 = Destination Address  
0x70 = Source Address  
0x01 = Data Field Length  
0xAA = Command Code  
0xE4 = Checksum

The reading meanings of returning HEX code are as the following:

0xAB = Header  
0x70 = Destination Address  
0x01 = Source Address  
0x02 = Data Field Length  
0xAA = Command Code  
0x01 = "01"Key Board Lock ON, Recall Key Lock OFF (Return Data)  
0xE2 = Checksum

### Initialize All Steps Parameters

---

Description: It sets all steps to the initial setting, this command will delete all steps.

Command code: 0x2C

Parameter: None

Return data: Reply Message

Example: Master (0x70): 0xAB 0x01 0x70 0x01 0x2C 0x62

Slave (0x01): 0xAB 0x70 0x01 0x02 0x7F 0x00 0x0E

### Descriptions of example

The setting meanings of HEX inputs are as the following:

0xAB = Header

0x01 = Destination Address  
0x70 = Source Address  
0x01 = Data Field Length  
0x2C = Command Code  
0x62 = Checksum

The reading meanings of returning HEX code are as the following:

0xAB = Header  
0x70 = Destination Address  
0x01 = Source Address  
0x02 = Data Field Length  
0x7F = Reply Message Command Code  
0x00 = Reply Message Return Data  
0x0E = Checksum

### Step Number?

---

Description: It queries the step numbers of being set.

Command code: 0xAD

Parameter: None

Return data: 1 byte data

Example: Master (0x70): 0xAB 0x01 0x70 0x01 0xAD 0xE1  
Slave (0x01): 0xAB 0x70 0x01 0x02 0xAD 0x05 0xDB

### Descriptions of example

The setting meanings of HEX inputs are as the following:

0xAB = Header  
0x01 = Destination Address  
0x70 = Source Address  
0x01 = Data Field Length  
0xAD = Command Code  
0xE1 = Checksum

The reading meanings of returning HEX code are as the following:

0xAB = Header  
0x70 = Destination Address  
0x01 = Source Address  
0x02 = Data Field Length  
0xAD = Command Code  
0x05 = "05" the step numbers of being set (Return Data)  
0xDB = Checksum

### Remote/Local

---

Description: It switches the device to remote or local control.

Command code: 0x2E

Parameter: 1 byte  
0: Go to Local.  
1: Go to Remote.  
2: Go to Remote and Local Lockout

Return data: Reply Message

Example: Master (0x70): 0xAB 0x01 0x70 0x02 0x2E 0x01 0x5E  
Slave (0x01): 0xAB 0x70 0x01 0x02 0x7F 0x00 0x0E

### Descriptions of example

The setting meanings of HEX inputs are as the following:

0xAB = Header  
0x01 = Destination Address  
0x70 = Source Address  
0x02 = Data Field Length  
0x2E = Command Code  
0x01 = "1"Go to Remote (Command Parameter)  
0x5E = Checksum

The reading meanings of returning HEX code are as the following:

0xAB = Header  
0x70 = Destination Address  
0x01 = Source Address  
0x02 = Data Field Length  
0x7F = Reply Message Command Code  
0x00 = Reply Message Return Data  
0x0E = Checksum

### Remote Status?

---

Description: It queries remote status of the device.

Command code: 0xAE

Parameter: None

Return data: 1 byte data

0: Local

1: Remote

2: Remote and Local Lockout

Example: Master (0x70): 0xAB 0x01 0x70 0x01 0xAE 0xE0

Slave (0x01): 0xAB 0x70 0x01 0x02 0xAE 0x01 0xDE

### Descriptions of example

The setting meanings of HEX inputs are as the following:

0xAB = Header  
0x01 = Destination Address  
0x70 = Source Address  
0x01 = Data Field Length  
0xAE = Command Code  
0xE0 = Checksum

The reading meanings of returning HEX code are as the following:

0xAB = Header  
0x70 = Destination Address  
0x01 = Source Address  
0x02 = Data Field Length  
0xAE = Command Code  
0x01 = "1" Remote (Return Data)  
0xDE = Checksum

### Set C Standard

---

Description: It sets the standard capacitance of OS mode.

Command code: 0x2F

Parameter: 6 byte

Name	Size (byte)	Unit	Range	Description
Step Index	1	-	1~10	
C Standard	4	pF	0~25100 0~5000	When Short Limit is OFF, Max. is 25100. When Short Limit is not OFF, Max. is 5000.
Range	1	-	1~3	3 is maximum range

Return data: Reply Message

Example: Master (0x70): 0xAB 0x01 0x70 0x07 0x2F 0x01 0x00 0x04 0x00 0x00  
0x01 0x53  
Slave (0x01): 0xAB 0x70 0x01 0x02 0x7F 0x00 0x0E

### Descriptions of example

The setting meanings of HEX inputs are as the following:

0xAB = Header

0x01 = Destination Address

0x70 = Source Address

0x07 = Data Field Length

0x2F = Command Code

0x01 = Step Index 1(setting data)

0x00 0x04 0x00 0x00 = C Standard 1024pF(setting data)

0x01 = Range 1(setting data)

0x53 = Checksum

The reading meanings of returning HEX code are as the following:

0xAB = Header

0x70 = Destination Address

0x01 = Source Address

0x02 = Data Field Length

0x7F = Reply Message Command Code

0x00 = Reply Message Return Data

0x0E = Checksum

### Result?

Description: It queries the test result and measurement value.

Command code: 0xB1

Parameter: 2 bytes, serial numbers of steps + items of measurement values, the range of serial numbers of steps is 0 ~ 10. When the range is 0, it means to query the last one which starts to perform or the step which be performed completely. According to the weight of 2 to divide the measurement value option into 8 items, if queries multi-item simultaneously, the lesser weight is sent at first.

The measurement value option:

#### AC mode

Item Number	Name	Size (byte)	Unit	Description
1	Mode	1	-	1:AC Mode
2	Meter 1 (Source)	2	V	30000: Maximum, 31000: Not Value
4	Meter 2 (Current)	4	100nA	1000000000: Maximum, 1100000000: Not Value
8	Meter 3	4	-	Reserved
16	Ramp Time	2	100mS	30000: Maximum, 31000: Not Value
32	Reserved	2	-	Reserved
64	Test Time	2	100mS	30000: Maximum, 31000: Not Value
128	Fall Time	2	100mS	30000: Maximum, 31000: Not Value

**DC mode**

Item Number	Name	Size (byte)	Unit	Description
1	Mode	1	-	2:DC Mode
2	Meter 1 (Source)	2	V	30000: Maximum, 31000: Not Value
4	Meter 2 (Current)	4	100nA	1000000000: Maximum, 1100000000: Not Value
8	Meter 3 (Inrush)	4	100nA	1000000000: Maximum, 1100000000: Not Value
16	Ramp Time	2	100mS	30000: Maximum, 31000: Not Value
32	Dwell Time	2	100mS	30000: Maximum, 31000: Not Value
64	Test Time	2	100mS	30000: Maximum, 31000: Not Value
128	Fall Time	2	100mS	30000: Maximum, 31000: Not Value

**IR mode**

Item Number	Name	Size (byte)	Unit	Description
1	Mode	1	-	3:IR Mode
2	Meter 1 (Source)	2	V	30000: Maximum, 31000: Not Value
4	Meter 2 (Resistance)	4	100kOhm	1000000000: Maximum, 1100000000: Not Value
8	Meter 3	4	-	Reserved
16	Ramp Time	2	100mS	30000: Maximum, 31000: Not Value
32	Dwell Time	2	100mS	30000: Maximum, 31000: Not Value
64	Test Time	2	100mS	30000: Maximum, 31000: Not Value
128	Fall Time	2	100mS	30000: Maximum, 31000: Not Value

**GC mode**

Item Number	Name	Size (byte)	Unit	Description
1	Mode	1	-	4:GC Mode
2	Meter 1 (Source)	2	mA	30000: Maximum, 31000: Not Value
4	Meter 2 (Resistance)	4	100mOhm	1000000000: Maximum, 1100000000: Not Value
8	Meter 3	4	-	Reserved
16	Reserved	2	-	Reserved
32	Dwell Time	2	100mS	30000: Maximum, 31000: Not Value
64	Reserved	2	-	Reserved
128	Reserved	2	-	Reserved

**PA mode**

Item Number	Name	Size (byte)	Unit	Description
1	Mode	1	-	5:PA Mode
2	Under Test Signal	2	-	1:Off, 2:On
4, 8, 16, 32, 64 or 128	Message	16	-	C String, maximum length is 15

**OS mode**

Item Number	Name	Size (byte)	Unit	Description
1	Mode	1	-	6:OS Mode
2	Meter 1 (Source)	2	V	30000: Maximum, 31000: Not Value
4	Meter 2 (capacitance)	4	pF	1000000000: Maximum, 1100000000: Not Value
8	Reserved	4	-	Reserved
16	Reserved	2	-	Reserved
32	Reserved	2	-	Reserved
64	Test Time	2	100mS	30000: Maximum, 31000: Not Value
128	Reserved	2	-	Reserved

Return data: The flag of new test result (1 byte) + serial number of step (1 byte) + test result (1 byte) + measurement value option (1 byte) [ + measurement value 1 + measurement value 2 + ...]

The flag is with new test result: it is the correct flag that can judge the measurement result. This flag set as ON when the test is initiated, and set as OFF when the test is stopped. Alternatively, the test is ended and the result is read by this command, then set as OFF. Thus, only in the test duration, the test completed or uses this command to read first time, this flag is ON otherwise is OFF.

**Return test result codes:**

Mode Code	AC		DC		IR		GC		OS		ALL	
	HEX	DEC	HEX	DEC	HEX	DEC	HEX	DEC	HEX	DEC	HEX	DEC
STOP											70	112
USER INTERRUPT											71	113
CAN NOT TEST											72	114
TESTING PASS											73	115
SKIPPED											74	116
GFI TRIPPED											75	117
											79	121
SLAVE FAIL											7A	122
Cs/SHORT FAIL											7B	123
HIGH FAIL	11	17	21	33	31	49	41	65				
SHORT FAIL									61	97		
LOW FAIL	12	18	22	34	32	50	42	66				
OPEN FAIL									62	98		
ARC FAIL	13	19	23	35								
I/O FAIL	14	20	24	36	34	52			64	100		
NO OUTPUT	15	21	25	37	35	53						
VOLTAGE OVER	16	22	26	38	36	54			66	102		
CURRENT OVER	17	23	27	39	37	55			67	103		
INRUSH FAIL			28	40								

Example: The test results of devices:

Master (0x70): 0xAB 0x01 0x70 0x03 0xB1 0x00 0xD7 0x04

Slave (0x01): 0xAB 0x70 0x01 0x12 0xB1 0x01 0x01 0x74 0xD7 0x01  
 0x63 0x00 0x5A 0x00 0x00 0x00 0x0F 0x00 0x1E 0x00  
 0x18 0x00 0x7C

**Descriptions of example**

The setting meanings of HEX inputs are as the following:

0xAB = Header

0x01 = Destination Address

0x70 = Source Address

0x03 = Data Field Length

0xB1 = Command Code

0x00 = "00" It queries the last step that begins to execute or have been executed.

(Command Parameter)

0xD7 = "D7" Item Number (Command Parameter)

0x04 = Checksum

The reading meanings of returning HEX code are as the following:

0xAB = Header

0x70 = Destination Address  
0x01 = Source Address  
0x12 = Data Field Length  
0xB1 = Command Code  
0x01 = New test result (Return Data)  
0x01 = Step1 (Return Data)  
0x74 = Test result code "PASS" (Return Data)  
0xD7 = Item number (Return Data)  
0x01 = AC mode (Return Data)  
0x63 0x00 = Display Volt 0.099kV (Return Data)  
0x5A 0x00 0x00 0x00 = Curr 0.009mA (Return Data)  
0x0F 0x00 = ramp time 1.5sec (Return Data)  
0x1E 0x00 = test time 3.0sec (Return Data)  
0x18 0x00 = fall time 2.4sec (Return Data)  
0x7C = Checksum

 **Notice** When the tester is pause mode, the data field length of returning may be different from other modes.

### Do Get C Standard

---

Description: It enables the standard capacitance get function of OS mode.  
Command code: 0x33  
Parameter: None  
Return data: Reply Message  
Example: Master (0x70): 0xAB 0x01 0x70 0x01 0x33 0x5B  
Slave (0x01): 0xAB 0x70 0x01 0x02 0x7F 0x00 0x0E

### Descriptions of example

The setting meanings of HEX inputs are as the following:

0xAB = Header  
0x01 = Destination Address  
0x70 = Source Address  
0x01 = Data Field Length  
0x33 = Command Code  
0x5B = Checksum

The reading meanings of returning HEX code are as the following:

0xAB = Header  
0x70 = Destination Address  
0x01 = Source Address  
0x02 = Data Field Length  
0x7F = Reply Message Command Code  
0x00 = Reply Message Return Data  
0x0E = Checksum

### Reply Message

---

Description: It queries the performed result of previous command.  
Command code: 0x7F  
Parameter: None  
Return data: 1 byte  
0 – OK, no error  
1 – Command Error (Include Execution Error)  
2 – Parameter Error

Example:       Master (0x70): 0xAB 0x01 0x70 0x01 0x7F 0x0F  
                  Slave (0x01): 0xAB 0x70 0x01 0x02 0x7F 0x00 0x0E

**Descriptions of example**

Inputted setting meanings of HEX are as the following:

0xAB = Header  
0x01 = Destination Address  
0x70 = Source Address  
0x01 = Data Field Length  
0x7F = Command Code  
0x0F = Checksum

The reading meanings of returning HEX code are as the following:

0xAB = Header  
0x70 = Destination Address  
0x01 = Source Address  
0x02 = Data Field Length  
0x7F = Command Code  
0x00 = "00"OK, no error (Return Data)  
0x0E = Checksum

## 5.7 Flow Diagram

1. Confirm if all of Slaves' communication is normal or not:

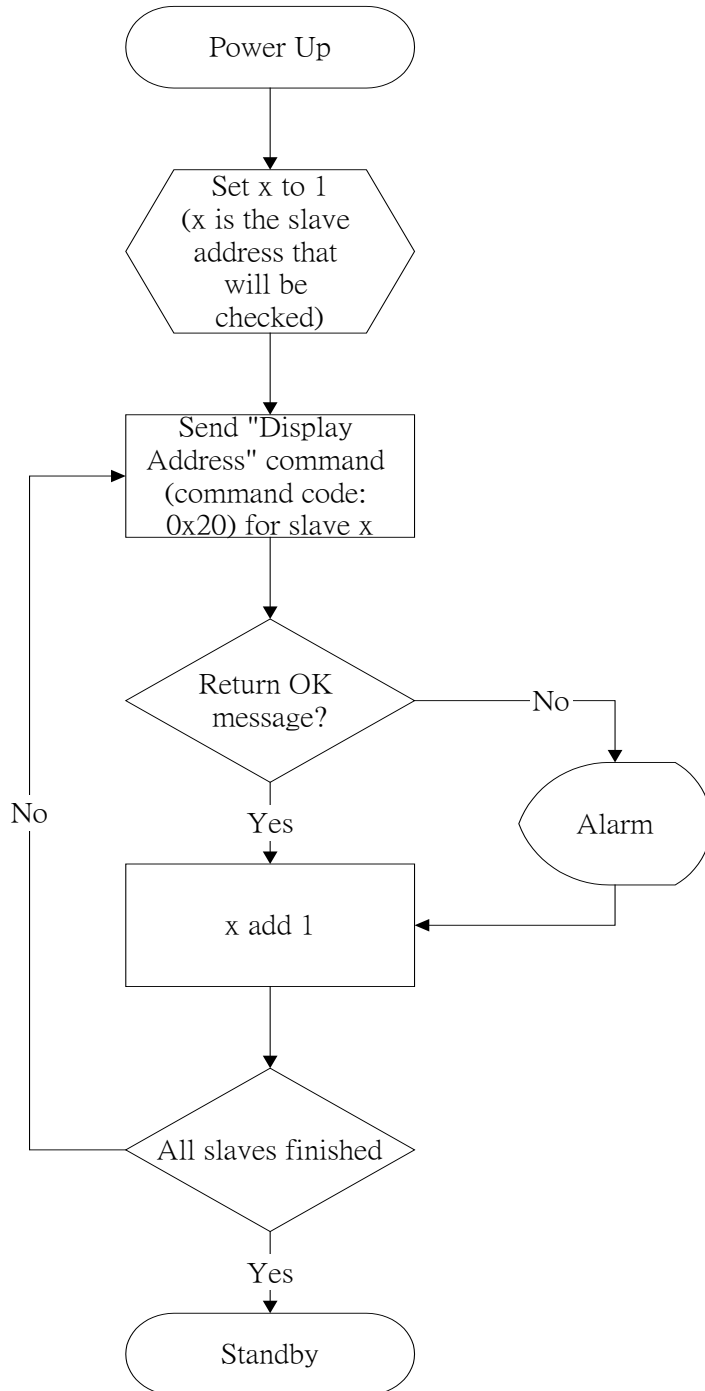

2. Upload the test steps from one slave then download to all slaves.

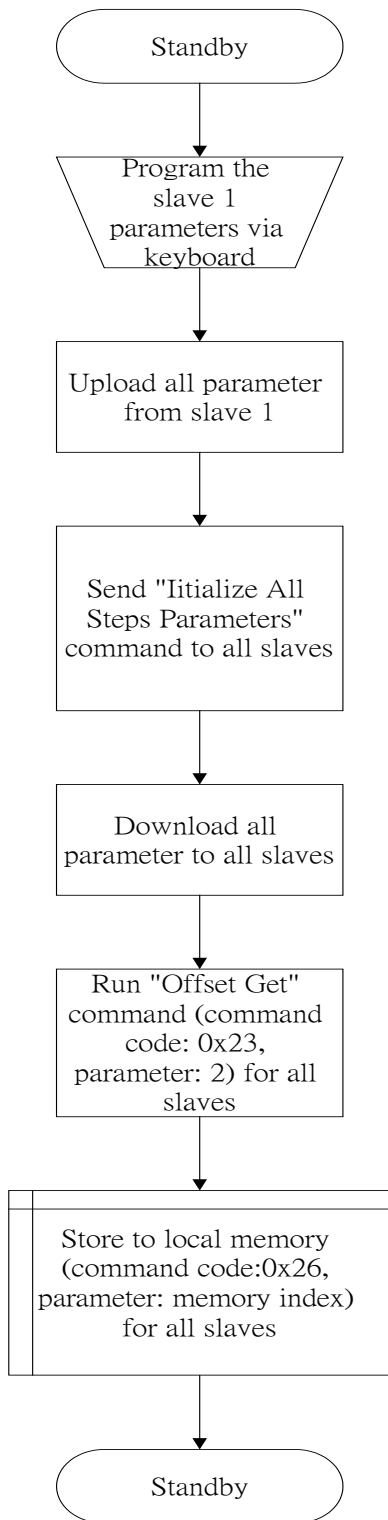

3. Read the measurement data:

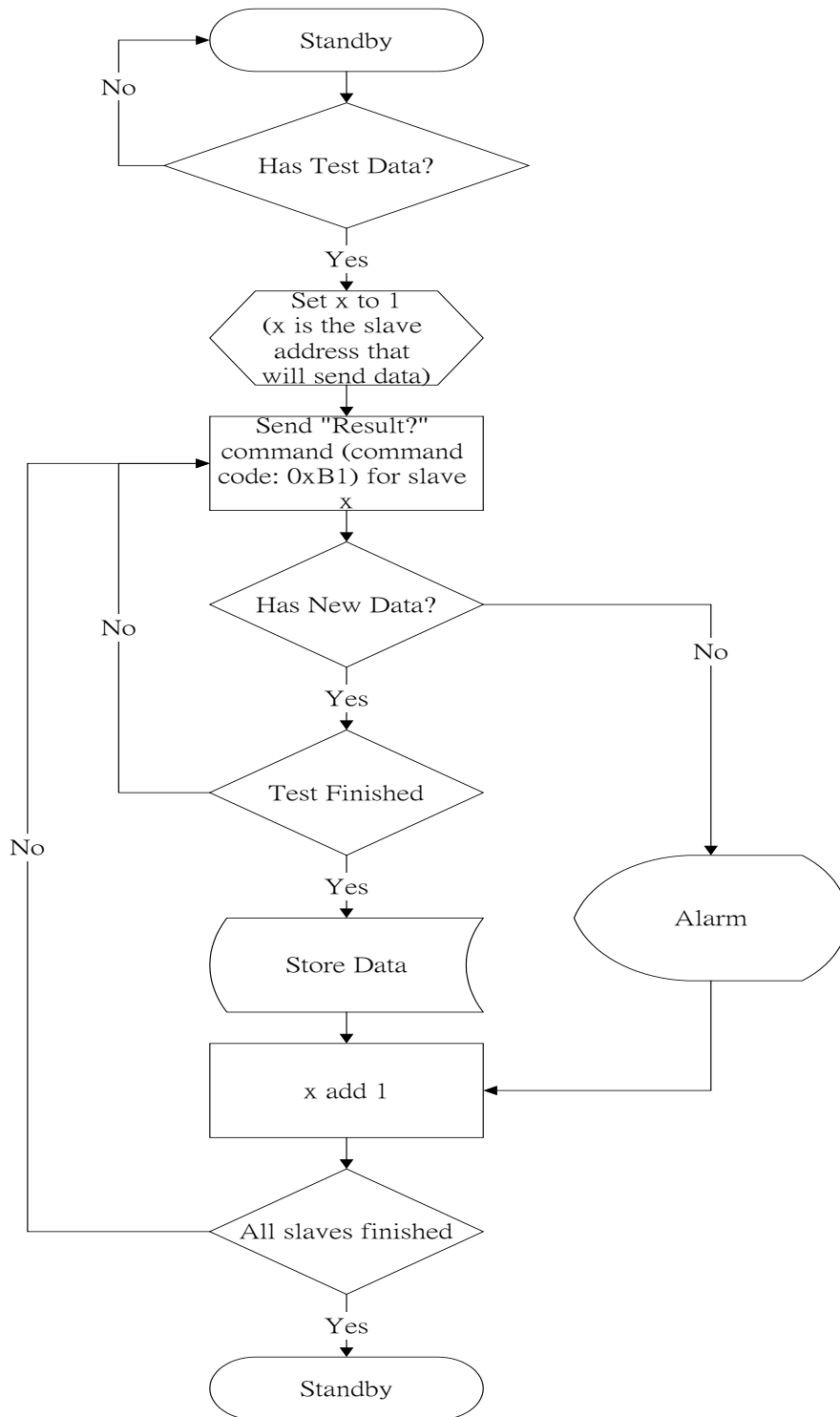

## 6. RS232 Interface

### 6.1 Guide

Users can use computer via RS232 interface to remote control for the tester. This interface applies binary code transmission mode, its command format is the same as RS485 interface. The detail command description, please see *section 5.6 Command Description*.

### 6.2 Interface Specification

It's a standard RS232 interface, the setting value as the following:

BAUD RATE : 4800/9600/19200  
 PARITY : NONE  
 FLOW CTRL. : NONE

### 6.3 RS-232 Single Unit Connection for Parameter Setting

1. Press **MENU** under "STANDBY" screen, by using **F1**, **F2** to move the highlight to "OPTION". Next to press **SELECT** to move the highlight to "REMOTE INTERFACE" then press **SELECT** to enter RS485 setting screen.
2. Use **NEXT** to move the highlight, and **UP**, **DOWN** to change the settings.
3. Setting item descriptions for single unit connecting:
  - a. INTERFACE: Select RS485 interface
  - b. UNIT TYPE: Select device type as SLAVE.
  - c. BAUD RATE: Select transmission as 4800, 9600 or 19200 baud rate.
  - d. UNIT ADDRESS: Set as 1.

### 6.4 Connector

RS232 connector of the instrument is a 9-pin D-Sub connector.

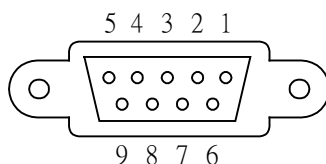

Pin Number	Description
1	*
2	TxD
3	RxD
4	*
5	GND
6	*
7	*
8	*
9	*

## 6.5 Method of Connecting

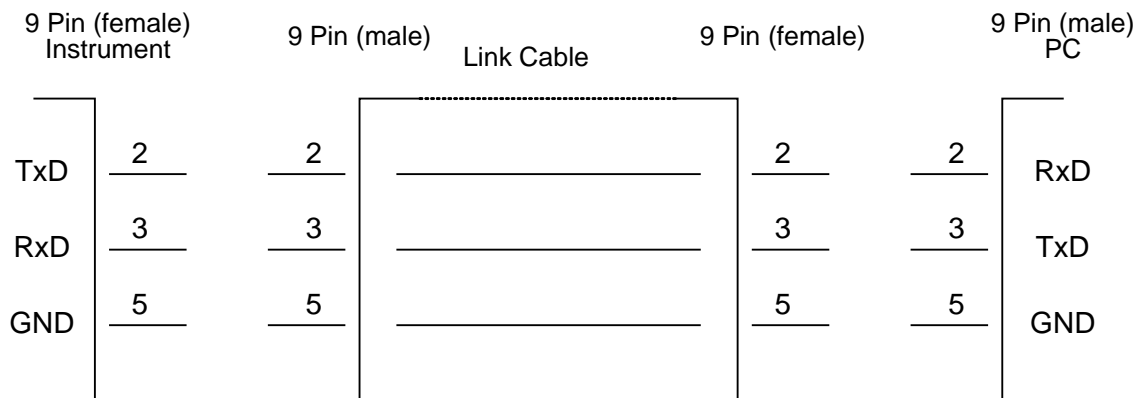

## 6.6 Communication Protocol

This interface applies binary code transmission mode which is the same as RS485, the given command needs to include destination address and source address. The RS-485 UNIT ADDRESS setting is 1 as connecting single unit, thus set destination address to 0x01 and source address to 0x70. About command format, please refer *section 5.4 Communication Protocol*.

## 7. Maintenance

### 7.1 General

Our warranty (at the front of the manual) attests the quality of materials and workmanship in our products. If malfunction should be suspected, or other information be desired applications engineers are available for technical assistance. Application assistance is available in Taiwan by calling 886-3-3279999 and asking for applications support. For support outside of Taiwan please contact your local Chroma distributor.

### 7.2 Instrument Return

Before returning an instrument to Chroma for service, please call our Service Department at 886-3-3279688 for return material authorization. It will be necessary to include a purchase order number to ensure expedient processing, although units found to be in warranty period will be repaired at no-charge. For any questions on repair costs or shipment instructions please contact our service department at the above number. To safeguard an instrument during storage and shipping please use packaging that is adequate to protect it from damage, i.e., equivalent to the original packaging and mark the box "Delicate Electronic Instrument". Return material should be sent freight prepaid, to:

**Chroma Ate Inc.**  
**66 Huaya 1st Road, Guishan, Taoyuan 33383, Taiwan**  
**Attention: Service Department**



## **Chroma's Continuous Quality Process User Manual Customer Feedback**

Chroma welcomes all comments and recommendations to improve this publication in the future editions. Please scan the QR code below or click the URL <http://www.chromaate.com/survey?n=793ce6db-17ef-4cd3-b0de-8bbd09aa38e0> to fill in the customer feedback form. Thank you!





CHROMA ATE INC.

致茂電子股份有限公司

66 Huaya 1st Road,

Guishan, Taoyuan 33383, Taiwan

台灣桃園市 33383 龜山區

華亞一路 66 號

T +886-3-327-9999

F +886-3-327-8898

Mail: [info@chromaate.com](mailto:info@chromaate.com)

<http://www.chromaate.com>