

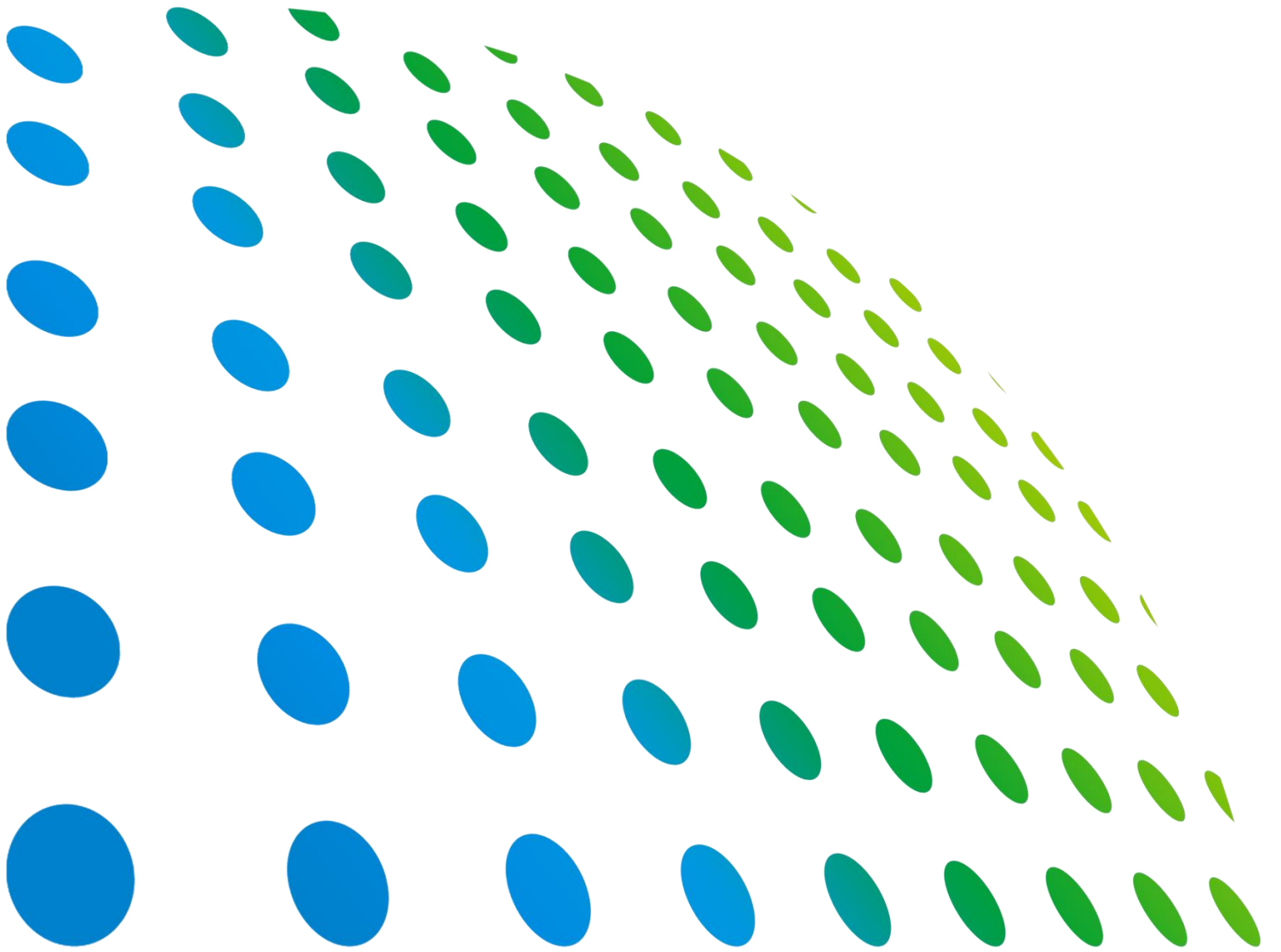

Wound Component EST Analyzer

19036

User's Manual



Get more product & global distributor information in Chroma ATE APP



Wound Component EST Analyzer 19036 User's Manual

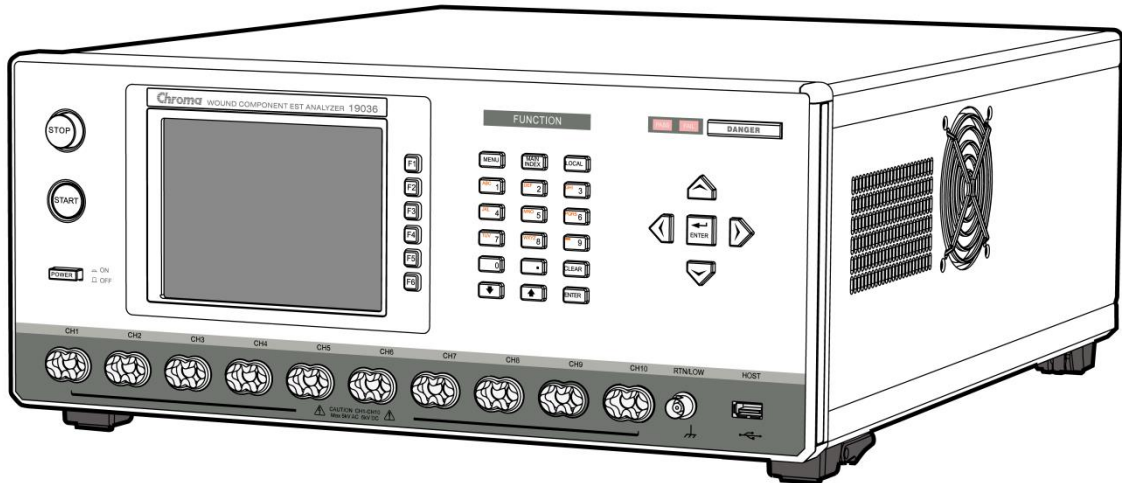

Version 2.1
September 2022

Legal Notices

The information in this document is subject to change without notice.

Chroma ATE INC. makes no warranty of any kind with regard to this manual, including, but not limited to, the implied warranties of merchantability and fitness for a particular purpose. Chroma ATE INC. shall not be held liable for errors contained herein or direct, indirect, special, incidental or consequential damages in connection with the furnishing, performance, or use of this material.

CHROMA ATE INC.

88 Wenmao Rd., Guishan Dist., Taoyuan City 333001, Taiwan

Copyright Notices. Copyright 2013 Chroma ATE INC., all rights reserved. Reproduction, adaptation, or translation of this document without prior written permission is prohibited, except as allowed under the copyright laws.

Warranty

All of Chroma's instruments are warranted against defects in material and workmanship for a period of one year from date of shipment. Chroma agrees to repair or replace any assembly or component found to be defective, under normal use during this period. Chroma's obligation under this warranty is limited solely to repairing any such instrument, which in Chroma's sole opinion proves to be defective within the scope of the warranty when returned to the factory or to an authorized service center. Purchaser is responsible for the shipping and cost of the service item to Chroma factory or service center. Shipment should not be made without prior authorization by Chroma.

This warranty does not apply to any products repaired or altered by persons not authorized by Chroma, or not in accordance with instructions furnished by Chroma. If the instrument is defective as a result of misuse, improper repair, or abnormal conditions or operations, repairs will be billed at cost.

Chroma assumes no responsibility for its product being used in a hazardous or dangerous manner either alone or in conjunction with other equipment. High voltage used in some instruments may be dangerous if misused. Special disclaimers apply to these instruments. Chroma assumes no liability for secondary charges or consequential damages and in any event, Chroma's liability for breach of warranty under any contract or otherwise, shall not exceed the purchase price of the specific instrument shipped and against which a claim is made.

Any recommendations made by Chroma regarding the use of its products are based upon tests believed to be reliable; Chroma makes no warranty of the results to be obtained. This warranty is in lieu of all other warranties, expressed or implied, and no representative or person is authorized to represent or assume for Chroma any liability in connection with the sale of our products other than set forth herein.

Chroma undertakes no liability for any special or consequential damages, or any of our customer's compensation responsibilities to third parties, arising from use or access of our product.

CHROMA ATE INC.

88 Wenmao Rd., Guishan Dist.

Taoyuan City 333001, Taiwan

Tel: 886-3-327-9999

Fax: 886-3-327-8898

e-mail: info@chromaate.com

www.chromaate.com

Material Contents Declaration

The recycling label shown on the product indicates the Hazardous Substances contained in the product as the table listed below.

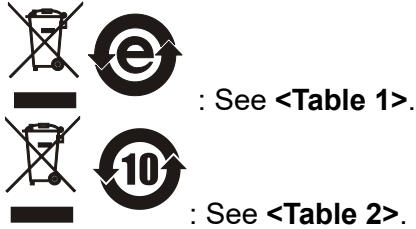

<Table 1>

Part Name	Hazardous Substances					
	Lead	Mercury	Cadmium	Hexavalent Chromium	Polybrominated Biphenyls/ Polybromodiphenyl Ethers	Selected Phthalates Group
	Pb	Hg	Cd	Cr ⁶⁺	PBB/PBDE	DEHP/BBP/DBP/DIBP
PCBA	O	O	O	O	O	O
CHASSIS	O	O	O	O	O	O
ACCESSORY	O	O	O	O	O	O
PACKAGE	O	O	O	O	O	O

“O” indicates that the level of the specified chemical substance is less than the threshold level specified in the standards of SJ/T-11363-2006, EU Directive 2011/65/EU, and 2015/863/EU.

“X” indicates that the level of the specified chemical substance exceeds the threshold level specified in the standards of SJ/T-11363-2006, EU Directive 2011/65/EU, and 2015/863/EU.

Remarks:

1. The CE marking on product is a declaration of product compliance with EU Directive 2011/65/EU and 2015/863/EU.
2. This product is complied with EU REACH regulation and no SVHC in use.

Disposal

Do not dispose of electrical appliances as unsorted municipal waste, use separate collection facilities. Contact your local government for information regarding the collection systems available. If electrical appliances are disposed of in landfills or dumps, hazardous substances can leak into the groundwater and get into the food chain, damaging your health and well-being. When replacing old appliances with new one, the retailer is legally obligated to take back your old appliances for disposal at least for free of charge.



<Table 2>

Part Name	Hazardous Substances					
	Lead	Mercury	Cadmium	Hexavalent Chromium	Polybrominated Biphenyls/ Polybromodiphenyl Ethers	Selected Phthalates Group
	Pb	Hg	Cd	Cr ⁶⁺	PBB/PBDE	DEHP/BBP/DBP/DIBP
PCBA	×	○	○	○	○	○
CHASSIS	×	○	○	○	○	○
ACCESSORY	×	○	○	○	○	○
PACKAGE	○	○	○	○	○	○

“O” indicates that the level of the specified chemical substance is less than the threshold level specified in the standards of SJ/T-11363-2006, EU Directive 2011/65/EU, and 2015/863/EU.

“×” indicates that the level of the specified chemical substance exceeds the threshold level specified in the standards of SJ/T-11363-2006, EU Directive 2011/65/EU, and 2015/863/EU.

1. Chroma is not fully transitioned to lead-free solder assembly at this moment; however, most of the components used are RoHS compliant.
2. The environment-friendly usage period of the product is assumed under the operating environment specified in each product’s specification.
3. This product is complied with EU REACH regulation and no SVHC in use.

Disposal

Do not dispose of electrical appliances as unsorted municipal waste, use separate collection facilities. Contact your local government for information regarding the collection systems available. If electrical appliances are disposed of in landfills or dumps, hazardous substances can leak into the groundwater and get into the food chain, damaging your health and well-being. When replacing old appliances with new one, the retailer is legally obligated to take back your old appliances for disposal at least for free of charge.





Declaration of Conformity

For the following equipment :

Wound Component EST Analyzer/ Impulse Winding Tester

(Product Name/ Trade Name)

19036, 19305, 19305-10

(Model Designation)

CHROMA ATE INC.

(Manufacturer Name)

88 Wenmao Rd., Guishan Dist., Taoyuan City 333001, Taiwan

(Manufacturer Address)

Is herewith confirmed to comply with the requirements set out in the Council Directive on the Approximation of the Laws of the Member States relating to Electromagnetic Compatibility (2014/30/EU) and Low Voltage Directive (2014/35/EU). For the evaluation regarding the Directives, the following standards were applied :

EN 61326-1:2013 Class A

EN 61000-3-2:2014, EN 61000-3-3:2013

EN 61326-1:2013(industrial locations)

EN 61000-4-2:2009, EN 61000-4-3:2006+A1:2008+A2:2010, EN 61000-4-4:2012,

EN 61000-4-5:2006, EN 61000-4-6:2014, EN 61000-4-8:2010, EN 61000-4-11:2004

EN 61010-1:2010 and EN 61010-2-030:2010

The equipment describe above is in conformity with Directive 2011/65/EU and 2015/863/EU of the European Parliament and of the Council on the restriction of the use of certain hazardous substances in electrical and electronic equipment.

The following importer/manufacturer or authorized representative established within the EUT is responsible for this declaration :

CHROMA ATE INC.

(Company Name)

88 Wenmao Rd., Guishan Dist., Taoyuan City 333001, Taiwan

(Company Address)

Person responsible for this declaration:

Mr. Vincent Wu

(Name, Surname)

T&M BU Vice President

(Position/Title)

Taiwan

(Place)

2020.12.23

(Date)

(Legal Signature)

Safety Summary

The following general safety precautions must be observed during all phases of operation, service, and repair of this product. Failure to comply with these precautions or specific WARNINGS given elsewhere in this manual will violate safety standards of design, manufacture, and intended use of the instrument. *Chroma* assumes no liability for the customer's failure to comply with these requirements.



BEFORE APPLYING POWER

Verify that the power is set to match the rated input of this device.



PROTECTIVE GROUNDING

Make sure to connect the protective grounding to prevent an electric shock before turning on the power.

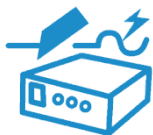

NECESSITY OF PROTECTIVE GROUNDING

Never cut off the internal or external protective grounding wire, or disconnect the wiring of protective grounding terminal. Doing so will cause a potential shock hazard that may bring injury to a person.



FUSES

Only fuses with the required rated current, voltage, and specified type (normal blow, time delay, etc.) should be used. Do not use repaired fuses or short-circuited fuse holders. To do so could cause a shock or fire hazard.



DO NOT OPERATE IN AN EXPLOSIVE ATMOSPHERE

Do not operate the instrument in the presence of flammable gases or fumes. The instrument should be used in an environment of good ventilation.















DO NOT REMOVE THE COVER OF THE INSTRUMENT

Operating personnel must not remove the cover of the instrument. Component replacement and internal adjustment can be done only by qualified service personnel.

⚠ WARNING

1. Lethal voltage. The output may up to 6kV voltage.
2. Touching the connected circuit or output terminal on the front panel when power is on may result in death.

Safety Symbols

	DANGER – High voltage.
	Explanation: To avoid injury, death of personnel, or damage to the instrument, the operator must refer to the explanation in the instruction manual.
	High temperature: This symbol indicates the temperature is hazardous. Do not touch to avoid any personal injury.
	Protective grounding terminal: This symbol indicates that the terminal must be connected to ground before operation of the equipment to protect against electrical shock in case of a fault.
	Functional grounding: To identify an earth (ground) terminal in cases where the protective ground is not explicitly stated. This symbol indicates the power connector does not provide grounding.
	Frame or chassis: To identify a frame or chassis terminal.
	Alternating Current (AC)
	Direct Current (DC) / Alternating Current (AC)
	Direct Current (DC)
	Push-on/Push-off power switch
	The WARNING sign highlights an essential operating or maintenance procedure, practice, condition, statement, etc., which if not strictly observed, could result in injury to, or death of, personnel or long term health hazards.
	The CAUTION sign highlights an essential operating or maintenance procedure, practice, condition, statement, etc., which if not strictly observed, could result in damage to, or destruction of, equipment.
	The Notice sign highlights an essential operating or maintenance procedure, condition, or statement.

Unpacking for Check and Inspection

Before shipment this instrument was inspected and found to be free of mechanical and electrical defects. As soon as the instrument is unpacked, inspect for any damage that may have occurred in transit. Save all packing materials in case the instrument has to be returned. If damage is found, please file claim with carrier immediately. Do not return the instrument to Chroma without prior approval.

Standard Package



19036 Wound Component EST Analyzer

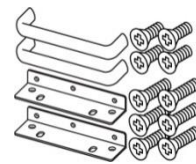

Ears & Handles



High Voltage Hazard Sticker



Warning Card

Standard Accessories (Cable)



Test Wire for HV Terminal
10 pcs.
(Bare Wires)



Test Wire for HV Terminal 2 pcs.
(with Small Alligator Clip)

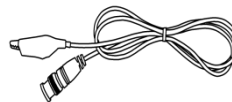

BNC Test Cable for RTN/LOW
1 pc.

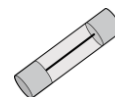

10.0A Fuse
2 pcs.

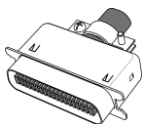

Handler Connector
1 pc.

Note : When additional items are required, contact Chroma and provide item's description.

Hazard Operations

1. Do not touch the testing area when this EST Analyzer is outputting voltage or you may get electric shock and it may cause death.

Be sure to obey the following:

- The earth wire must be connected exactly and use a standard power cord.
 - Do not touch the output terminal.
 - Do not touch the test wire that connected to the terminal in test.
 - Do not touch any unit under test.
 - Do not touch any component that connected to output terminal for charge.
 - Do not touch the test unit right after the test is ended or when the output is just turned off.
2. The electric shock incident may occur when:
 - The earth terminal of EST Analyzer is not connected properly.
 - The insulating gloves are not in use during test.
 - Users touch the test unit right after the test is done.
 3. Remote controlling the Tester: The EST Analyzer can be remote controlled generally for high voltage output via external control signal. When performing it, it is necessary to follow the control guidelines below for safety and precautions.
 - Do not allow any accidental high voltage output that may cause hazard.
 - When there is high voltage output from the Tester, do not allow any operator or other personnel to touch the DUT, test cable or probe output and etc.
 - Remote control is generally controlled by the high voltage test bar; however, other control circuits can also be used to control it instead. The test bar is the switch for controlling high voltage output, so the connected control wire should not near the high voltage site and test cable to avoid causing any hazard.

WARNING

Do not tie up the high voltage wire with RS232 and Handler control cables or other low voltage side wires. If so, it could cause the product or PC to be down or damaged.

DANGER

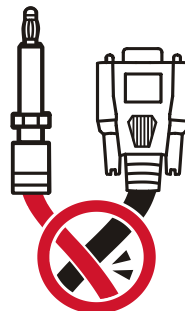

CAUTION

See Chapter 3 “*Precautions before Use*” for the details of using notes and dangerous operation.

Storage, Freight and Maintenance

Storage

When not in use, please pack the device properly and store in a suitable environment.

Freight

Please pack the device carefully before moving it. If any of the original packing material is missing, please use suitable alternative material and mark it “fragile” and “keep away from water” to avoid damaging the product.

This product is a piece of precision test equipment, so please do not drop or hit it.

Maintenance

In case of any malfunction or abnormality, please refer to the manual, or contact our local distributor for prompt service. Do not touch any parts inside the instrument to avoid any danger to yourself or damage to the product.

This product requires regular check and calibration to ensure it meets the specification. The suggested calibration period is 12 months.

Cleaning

Be sure to unplug the input power cord from the device before cleaning. Use a brush to clean the dust on the machine surface and use a low pressure air gun to clean the dust inside the device or send it to the agent for cleaning.

Revision History

The following lists the additions, deletions and modifications in this manual at each revision.

Date	Version	Revised Sections
May 2013	1.0	Complete this manual.
Dec. 2013	1.1	Modify the following sections: <ul style="list-style-type: none"> – “<i>Standard Accessories (Cable)</i>” in “<i>Unpacking for Check & Inspection</i>” – “<i>Features</i>” in the chapter of “<i>Preface</i>” – “<i>Setting SYSTEM CONFIG</i>” in the chapter of “<i>Operation</i>” – “<i>Commands for Remote Interface</i>” in the chapter of “<i>Using Remote Interface</i>” Delete “ <i> GPIB Interface (Option)</i> ” section in the chapter of “ <i>Using Remote Interface</i> ” Add “ <i>IWT BREAKDOWN VOLT MODE</i> ” section in the chapter of “ <i>Operation</i> ”
Oct. 2014	1.2	Modify the following sections: <ul style="list-style-type: none"> – “<i>Features</i>” in the chapter of “<i>Preface.</i>” – Note in the chapter of “<i>Specification.</i>” – Setting items in the section of “<i>Setting the SYSTEM</i>” under the chapter of “<i>Operation.</i>” – “<i>Pin Assignment</i>” and “<i>Timing Diagram</i>” in the chapter of “<i>HANDLER Interface.</i>” – “<i>Command Format</i>” and the SCPI commands in the section of “<i>Commands for Remote Interface</i>” under the chapter of “<i>Using Remote Interface.</i>” – “<i>DC Resistance Calibration</i>” in the chapter of “<i>Calibration Procedure.</i>”
Mar. 2015	1.3	Modify the following sections: <ul style="list-style-type: none"> – “<i>IWT Voltage Calibration</i>” section in the chapter of “<i>Calibration Procedure.</i>” – “<i>Command Format</i>” and the SCPI commands in the section of “<i>Commands for Remote Interface</i>” under the chapter of “<i>Using Remote Interface.</i>”
Sep. 2015	1.4	Modify the following sections: <ul style="list-style-type: none"> – Setting items of TEST CONTROL in the section of “<i>Setting TEST CONTROL</i>” under the chapter of “<i>Operation.</i>” – SCPI commands in the sections of “<i>Commands for Remote Interface</i>” and “<i>Command Description</i>” under the chapter of “<i>Using Remote Interface.</i>”
Sep. 2016	1.5	Update CE “ <i>Declaration of Conformity</i> ”.
Dec. 2016	1.6	Add the following sections: <ul style="list-style-type: none"> – “<i>Icon Indicator on Title Bar</i>” in the chapter of “<i>Operation</i>”. – “<i>Commands Differences List</i>” in the chapter of “<i>Using Remote Interface</i>”. Modify SCPI commands in the “ <i>Commands Summary</i> ” section.
Apr. 2017	1.7	Update CE “ <i>Declaration of Conformity</i> ”.
Oct. 2018	1.8	Modify the following: <ul style="list-style-type: none"> – “<i>Unpacking for Check & Inspection</i>” – “<i>Specifications</i>” chapter – “<i>Description of Parameters</i>”, “<i>EXPORT Function</i>” and “<i>IWT BREAKDOWN VOLT MODE</i>” sections in “<i>Operation</i>” chapter

		<ul style="list-style-type: none"> – “Pin Assignment” section in “HANDLER Interface” chapter – “Commands Summary” and “Command Description” sections in “Using Remote Interface” chapter
		Add the following:
		<ul style="list-style-type: none"> – “EXTERIOR CONNECT Test Procedure” and “AUTO EXPORT Function” sections in “Operation” chapter
		Delete the following:
		<ul style="list-style-type: none"> – “Setting CALIBRATION” section in “Operation” chapter – “Calibration Procedure” chapter
Mar. 2020	1.9	Update the following:
		<ul style="list-style-type: none"> – “Product Overview” section in “Preface” chapter – “Specifications” chapter – “Operation” chapter – “HANDLER Interface” chapter – “Usage of Impulse Test Modes” chapter – “Commands for Remote Interface” section in “Using Remote Interface” chapter
		Add “Using USB to Backup Host Memory” section to “Operation” chapter.
Jan. 2022	2.0	Change of Chroma headquarter address, “CE Declaration of Conformity” and the following:
		<ul style="list-style-type: none"> – “Specifications” chapter – “Description of Parameters”, “Temperature Measurement” and “Test Procedure for DCR”, “Test Procedure for IWT”, and “Test Procedure for Δ/Y DCR” sections in “Operation” chapter – “Pin Assignment” section in “HANDLER Interface” chapter – “Usage of Impulse Winding Test Modes” chapter – “Commands Summary” and “Command Description” sections in “Using Remote Interface” chapter
Sep. 2022	2.1	Update standard package in “Unpacking for Check and Inspection.”

Table of Contents

1. Preface	1-1
1.1 Product Overview	1-1
1.2 Features	1-1
1.3 Initial Inspection	1-2
1.4 Common Environment	1-2
1.5 Ambient Environment	1-3
2. Specifications (18°C ~ 28°C RH ≤ 70%)	2-1
3. Precautions before Use	3-1
4. Operation	4-1
4.1 Front Panel	4-1
4.2 Rear Panel	4-5
4.3 Notices before Use and Operating Procedure	4-6
4.4 Icon Indicator on Title Bar	4-6
4.5 Setting the SYSTEM	4-7
4.5.1 Entering the SYSTEM Setting Screen	4-7
4.5.2 Setting TEST CONTROL	4-7
4.5.3 Setting GFI (Ground Fault Interrupt)	4-9
4.5.4 Setting L CONDITIONS	4-10
4.5.5 Setting SYSTEM CONFIG	4-11
4.5.6 Setting KEY LOCK	4-12
4.5.7 Setting FAIL LOCK	4-13
4.5.8 Changing PASSWORD	4-15
4.5.9 Using USB to Backup Host Memory	4-15
4.6 Managing Programs and TEST CONTROL Memory	4-16
4.6.1 Entering the Memory Screen	4-16
4.6.2 Saving the Memory	4-17
4.6.3 Recalling the Memory	4-18
4.6.4 Using USB for Memory Management	4-19
4.6.5 Copying and Pasting the Memory	4-19
4.6.6 Deleting the Memory	4-21
4.6.7 Moving the Memory	4-22
4.7 Setting PROGRAM	4-23
4.7.1 Setting Program Procedure	4-23
4.7.2 Selecting Test Mode	4-24
4.7.3 Description of Parameters	4-25
4.7.4 Temperature Measurement	4-42
4.8 Using Open/Short Offset or Correction	4-48
4.8.1 Entering Open/Short Offset or Correction Screen	4-48
4.8.2 Using OPEN CIRCUIT	4-48
4.8.3 Using SHORT CIRCUIT	4-49
4.8.4 Using SAMPLE TEST	4-50
4.9 Setting and Using SUB Step	4-50
4.9.1 Setting SUB Step	4-50
4.10 Conducting the Test	4-51
4.10.1 Connecting the DUT	4-51
4.10.2 Test Procedure for AC/DC	4-52
4.10.3 Test Procedure for IR	4-53
4.10.4 Test Procedure for DCR	4-54
4.10.5 Test Procedure for IWT	4-55
4.10.6 Test Procedure for Δ/Y DCR	4-57

4.10.7	Test Procedure for IWT COMPARE	4-58
4.10.8	Test Procedure for HSCC	4-60
4.10.9	Test Procedure for OSC	4-61
4.10.10	Test Procedure for PA	4-63
4.10.11	Test Procedure for Lx	4-63
4.10.12	Test Procedure for Lx BALANCE	4-66
4.10.13	Test Procedure for EXTERIOR CONNECT	4-67
4.10.14	WV AUTO RANGE	4-68
4.11	Scan Test	4-69
4.12	EXPORT Function	4-69
4.13	AUTO EXPORT Function	4-69
4.14	IWT BREAKDOWN VOLT MODE	4-70
5.	HANDLER Interface	5-1
5.1	Specification	5-1
5.1.1	Driving Capability	5-1
5.1.2	Pin Assignment	5-1
5.2	Example of External Control Circuit	5-8
5.2.1	Example of Using Internal Power Supply	5-8
5.2.2	Example of Using External Power Supply	5-9
5.3	Timing Diagram	5-10
6.	Usage of Impulse Winding Test Modes	6-1
6.1	Features and Functions	6-1
6.2	Introduction to Impulse Test	6-1
6.3	Precautions for Setting up Impulse Testing Environment	6-2
6.4	PASS/FAIL Detection	6-2
6.5	Waveform Resolution	6-5
6.6	Setting Sampling Rate	6-6
6.7	Setting Pulse Number	6-7
6.8	Creating SAMPLE Waveform	6-8
6.9	Setting Conditions for Judging Good Product	6-8
6.10	Impulse Applied and Test Time	6-9
6.11	Impulse Applied and Residual Magnetic Field	6-9
6.12	Description of Laplacian	6-9
7.	Using Remote Interface	7-1
7.1	Introduction	7-1
7.2	RS232 Interface	7-1
7.2.1	Data Format	7-1
7.2.2	Command Format	7-1
7.2.3	Connector	7-1
7.2.4	Connection	7-2
7.3	USB Interface	7-3
7.3.1	Specification	7-3
7.3.2	Command Format	7-3
7.4	LAN Interface	7-3
7.4.1	Specification	7-3
7.4.2	Command Format	7-3
7.5	Commands for Remote Interface	7-4
7.5.1	Commands Summary	7-4
7.5.2	Commands Differences List	7-17
7.5.3	Command Description	7-17
7.5.4	SCPI System Status	7-72
7.6	Error Messages	7-73

1. Preface

1.1 Product Overview

The Chroma 19036 Wound Component EST Analyzer is an automatic equipment designed to perform AC/DC hipot test, IR test and impulse winding test to wound components. The maximum AC output is 100mA / 120mA (output voltage \leq 4kV) and DC output is 20mA. Besides the basic AC/DC hipot and IR tests, a new HFCC (High Frequency Contact Check) function is added in addition to the patented design OSC (Open Short Check) for contact check in production line test to improve the test reliability and efficiency.

For hipot test, the EST Analyzer has AC 5kV/DC 6kV high voltage output that can meet the hipot testing requirements for wound components. The maximum output current is up to AC 100mA/120mA (output voltage \leq 4kV)/ DC 20mA, which can be used for withstand voltage test on electronic and electrical devices as well as on the components.

In IR testing, the measurement range is 0.1M Ω ~ 50G Ω with voltage output up to 5kV to test if the insulation resistance of wound components complies with the standard. As to DCR test, besides measuring the basic specification of wound components it can be perform contact check before connecting for safety hipot test.

This EST Analyzer is able to test the wound components. Different STEP is able to call different main waveform data stored for impulse winding test to facilitate multiple series testing that is to recall different golden sample waveform.

Before doing high voltage test, Open or Short Check can be performed on the capacitor to ensure the DUT (Device Under Test) is in well contact for testing.

The HFCC (High Frequency Contact Check) can check if the tiny capacitance DUT is short or open before performing high voltage test to ensure the contact is in good condition for testing.

The display of the EST Analyzer is clear that all setting status including time, current, voltage, resistance and memory number can be seen on the screen without memorizing the status and parameters set previously.

The EST Analyzer is a device that can judge the product from good or no good and output signals for the test result. It has remote control device with RS233 and HANDLER interface to facilitate automatic test. In addition, it has DCR measurement temperature compensation interface available for use. With the above functions the EST Analyzer is able to perform highly efficient and accurate tests on wound components.

1.2 Features

- Impulse winding test
- Temperature compensation functions for DCR mode
- HFCC (High Frequency Contact Check) design
- HSCC (High Speed Contact Check) design
- OSC (Open Short Check) patented design

- Standard RS232 and USB interface on rear panel
- Front panel USB for storing programs
- Improved design of DC rapid discharge
- Key lock and data protection function
- Instruction window for 8 types of judgment results
- Breakdown voltage analysis
- Save up to 200 sets of memories in total and each memory set can save 60 test steps.

Note : IWT & IWT COMPARE can only save 40 test steps.

1.3 Initial Inspection

Before shipment, this Model 19036 was inspected and found to be free of mechanical and electrical defects. As soon as the instrument is unpacked, user should inspect for any damage that may have occurred in transit. Save all packing materials in case the Analyzer has to be returned. If damage is found, please file a claim with the carrier immediately. Do not return the product to Chroma without prior approval.

1.4 Common Environment

1. Indoor use only.
2. Altitude up to 2000 meters.
3. 2500V maximum transient overvoltage for main power supply.
4. Level II pollution degree.

1.5 Ambient Environment

1. Do not use the instrument in a dusty or vibrating location. Do not expose it to sunlight or corrosive gas. Be sure that the ambient temperature is $0^{\circ}\text{C} \sim +45^{\circ}\text{C}$ and that the relative humidity is between 15% ~ 95%.
2. The Model 19036 has been carefully designed to reduce the noise from the AC power source. However, it should be used in a noise-free or as low as possible environment. If noise is inevitable, please install a power filter.
3. The Model 19036 should be stored within the temperature range of $-10^{\circ}\text{C} \sim +50^{\circ}\text{C}$. If the unit is not going to be used for a long time, please store it in its original box or a similar package and keep it from direct sunlight and humidity.

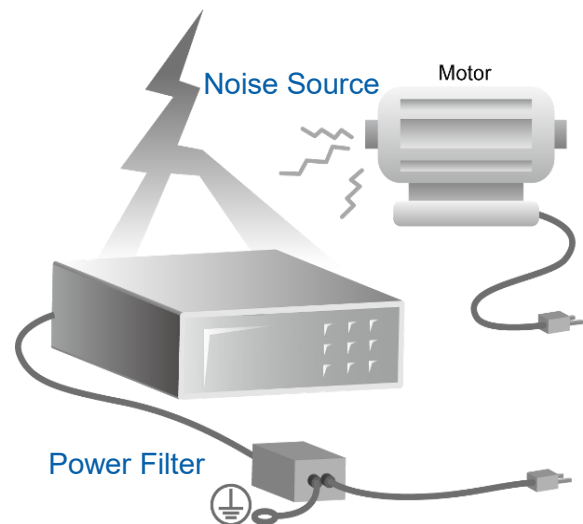
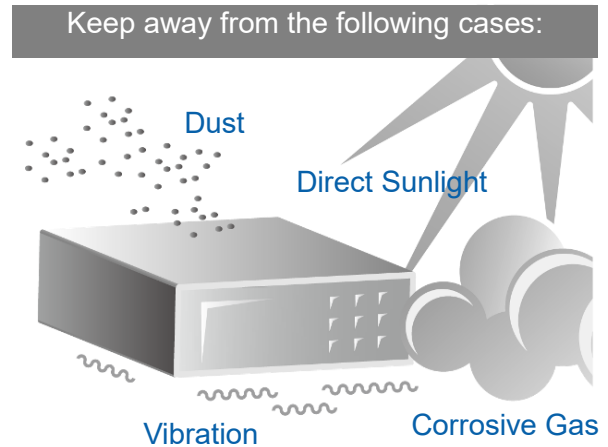

2. Specifications (18°C ~ 28°C RH ≤ 70%)

Specifications (18°C~28°C RH ≤ 70%)

□ Mode	ACV /DCV /IR /DCR /IWT /HSCC /PA /YDELTA/IWT_COMPARE /Lx /Lx_BALANCE/EXTERIOR CONNECT
□ Scanner (all testing mode)	10 Channel Programming: H/L/X
■ Withstanding Test (Note3)	
□ Output Voltage	AC: 0.050~5.000kV, steps 0.001kV, 50Hz/60Hz ± 0.1%,sine wave
	DC: 0.050~6.000kV, steps 0.001kV
	Voltage Accuracy: ± (1% of setting + 0.1% of full scale)
	Load Regulation: ≤ (1% of output + 0.1% of full scale), Rated load
□ Voltage monitor	±(1% of reading + 0.1% of full scale), 2V resolution
□ Cutoff Current	AC:
	Voltage ≤ 4kV: 0.001mA ~ 120mA
	Voltage > kV: 0.001mA ~ 100mA
	DC: 0.0001mA ~ 20mA
□ Leakage Current Meter	ACA
	3.000mA: 0.100mA~2.999mA, 0.001mA resolution
	30.00mA: 3.00mA~29.99mA, 0.01mA resolution
	120.0mA: 30.0mA~120mA, 0.1mA resolution
	DCA
	300uA: 0.1uA~299.9uA, 0.1uA resolution
	3.000mA: 0.300mA~2.999mA, 0.001mA resolution
	20.00mA: 3.00mA~20.00mA, 0.01mA resolution
	Measurement Accuracy: ±(1% of reading + 0.5% of full range)
	AC Real current measurement accuracy: ±(1% of reading + 5% total current + 5counts)
□ Flashover(ARC) Detection (Note 2)	AC: 1mA ~ 20mA, resolution 0.1mA DC: 1mA ~ 10mA, resolution 0.1mA
■ Insulation Resistance Test (Note 1)	
□ Output Voltage(DCV)	0.050 ~ 5.000 kV, steps 0.001kV
□ Voltage Accuracy (No AGC)	±(1% of setting + 0.1% of full scale)
□ Output Voltage monitor	±(1% of reading + 0.1% of full scale), 2V resolution
□ Resistance Range	<500V: 0.1MΩ ~ 1.00GΩ
	≥ 500V: 1.0MΩ ~ 50GΩ
□ Measuring Accuracy	>1000V:
	1MΩ ~ 1GΩ: ±(3% of reading + 0.1% of full scale)
	1GΩ ~ 10GΩ: ±(7% of reading + 2% of full scale)
	10GΩ ~ 50GΩ: ±(10% of reading + 1% of full scale)
	≥ 500V and ≤ 1000V:
	0.1MΩ ~ 1GΩ: ±(3% of reading + 0.1% of full scale)
	1GΩ ~ 10GΩ: ±(7% of reading + 2% of full scale)
10GΩ ~ 50GΩ: ±(10% of reading + 1% of full scale)	
< 500V:	
0.1MΩ ~ 1GΩ: ±(5% of reading+(0.2x500V/Vs)% of full scale)	
■ Test Time	Test Time: 0.3 ~ 999 sec., and Continue

	Ramp/Fall Time: 0.1 ~ 999 sec., and OFF DWEELL Time: 0.1 ~ 999 sec., and OFF(WDC only)																																								
■ OSC	(1) Test voltage level: Less than ac 200V, Test frequency 600Hz (2) No contact judge: Measured capacitance comparison. (Refer to attachment for detail) (3) Add SCPI command for entry Cs value & test range by customer directly																																								
■ HFCC (Note 4)	High Frequency Contact Check (1) No contact judge: Measured capacitance comparison. (Refer to attachment for detail). (2) Cs, Open, Short value setting in PROGRAM.																																								
■ HSCC	Typical 1kΩ.																																								
■ DC Resistance measurement (Four terminals)																																									
□ Test Signal	DC<5V, 1.25A max (design in spec)																																								
□ DCR Test Timer	Test Time: 0.1 ~ 999 sec., and Continue DWEELL Time: 0.1 ~ 999 sec., and Off Switch Time:0.01 ~ 0.2 sec.																																								
□ Test Range and accuracy	<table border="1"> <thead> <tr> <th>Range</th> <th>Test range</th> <th>Measurement Accuracy</th> <th>Limit Current</th> </tr> </thead> <tbody> <tr> <td>20mΩ</td> <td>2.000mΩ~20.000mΩ</td> <td>± (0.20% of reading + 0.08% of range)</td> <td>1.25A Typical</td> </tr> <tr> <td>200mΩ</td> <td>20.00mΩ~200.00mΩ</td> <td>± (0.15% of reading + 0.08% of range)</td> <td>100mA Typical</td> </tr> <tr> <td>2Ω</td> <td>0.2000Ω~2.0000Ω</td> <td>± (0.15% of reading + 0.08% of range)</td> <td>12.5mA Typical</td> </tr> <tr> <td>20Ω</td> <td>2.000Ω~20.000Ω</td> <td>± (0.15% of reading + 0.08% of range)</td> <td>1mA Typical</td> </tr> <tr> <td>200Ω</td> <td>20.00Ω~200.00Ω</td> <td>± (0.15% of reading + 0.06% of range)</td> <td>1mA Typical</td> </tr> <tr> <td>2kΩ</td> <td>0.2000kΩ~2.0000kΩ</td> <td>± (0.15% of reading + 0.03% of range)</td> <td>1mA Typical</td> </tr> <tr> <td>20kΩ</td> <td>2.000kΩ~20.000kΩ</td> <td>± (0.20% of reading + 0.03% of range)</td> <td>125uA Typical</td> </tr> <tr> <td>200kΩ</td> <td>20.00kΩ~200.00kΩ</td> <td>± (0.40% of reading + 0.03% of range)</td> <td>10uA Typical</td> </tr> <tr> <td>2MΩ</td> <td>0.2000MΩ~2.0000MΩ</td> <td>± (1.00% of reading + 0.03% of range)</td> <td>1.25uA Typical</td> </tr> </tbody> </table> <p>** The performance of this accuracy table requires the short correction, and the test time within 10 seconds. ** The specification applies to firmware visions above 3.00.</p>	Range	Test range	Measurement Accuracy	Limit Current	20mΩ	2.000mΩ~20.000mΩ	± (0.20% of reading + 0.08% of range)	1.25A Typical	200mΩ	20.00mΩ~200.00mΩ	± (0.15% of reading + 0.08% of range)	100mA Typical	2Ω	0.2000Ω~2.0000Ω	± (0.15% of reading + 0.08% of range)	12.5mA Typical	20Ω	2.000Ω~20.000Ω	± (0.15% of reading + 0.08% of range)	1mA Typical	200Ω	20.00Ω~200.00Ω	± (0.15% of reading + 0.06% of range)	1mA Typical	2kΩ	0.2000kΩ~2.0000kΩ	± (0.15% of reading + 0.03% of range)	1mA Typical	20kΩ	2.000kΩ~20.000kΩ	± (0.20% of reading + 0.03% of range)	125uA Typical	200kΩ	20.00kΩ~200.00kΩ	± (0.40% of reading + 0.03% of range)	10uA Typical	2MΩ	0.2000MΩ~2.0000MΩ	± (1.00% of reading + 0.03% of range)	1.25uA Typical
Range	Test range	Measurement Accuracy	Limit Current																																						
20mΩ	2.000mΩ~20.000mΩ	± (0.20% of reading + 0.08% of range)	1.25A Typical																																						
200mΩ	20.00mΩ~200.00mΩ	± (0.15% of reading + 0.08% of range)	100mA Typical																																						
2Ω	0.2000Ω~2.0000Ω	± (0.15% of reading + 0.08% of range)	12.5mA Typical																																						
20Ω	2.000Ω~20.000Ω	± (0.15% of reading + 0.08% of range)	1mA Typical																																						
200Ω	20.00Ω~200.00Ω	± (0.15% of reading + 0.06% of range)	1mA Typical																																						
2kΩ	0.2000kΩ~2.0000kΩ	± (0.15% of reading + 0.03% of range)	1mA Typical																																						
20kΩ	2.000kΩ~20.000kΩ	± (0.20% of reading + 0.03% of range)	125uA Typical																																						
200kΩ	20.00kΩ~200.00kΩ	± (0.40% of reading + 0.03% of range)	10uA Typical																																						
2MΩ	0.2000MΩ~2.0000MΩ	± (1.00% of reading + 0.03% of range)	1.25uA Typical																																						
■ Temp Compensation Port	(1) PT100 thermal sensor (Optional) (2) Measurement range & accuracy (the PT100 error not included) <table border="1"> <thead> <tr> <th>Range</th> <th>Measurement Accuracy</th> </tr> </thead> <tbody> <tr> <td>-10°C~39.9°C (14°F~103.8°F)</td> <td>± (0.3% of reading + 0.5°C)</td> </tr> <tr> <td>40.0°C ~100°C (104°F ~211.8°F)</td> <td>± (0.3% of reading + 1.0°C)</td> </tr> </tbody> </table>	Range	Measurement Accuracy	-10°C~39.9°C (14°F~103.8°F)	± (0.3% of reading + 0.5°C)	40.0°C ~100°C (104°F ~211.8°F)	± (0.3% of reading + 1.0°C)																																		
Range	Measurement Accuracy																																								
-10°C~39.9°C (14°F~103.8°F)	± (0.3% of reading + 0.5°C)																																								
40.0°C ~100°C (104°F ~211.8°F)	± (0.3% of reading + 1.0°C)																																								
■ Impulse Winding Test																																									
□ Applied Voltage	0.10kV~6.00kV , steps 0.01kV																																								
□ Voltage Accuracy	±(5% reading + 0.01kV)																																								
□ Energy	Max. 0.29 Joule per pulse																																								
□ Inductance Test Range	More than 10uH																																								
□ Sampling Range	11 Range																																								
□ Pulse Number	Pulse Number: 1~32, Dummy Pulse Number: 0~9																																								

<input type="checkbox"/> Detection Mode	Area Size Comparison Differential Area Comparison Flutter Comparison Laplacian Comparison
<input checked="" type="checkbox"/> Ground fault interrupt (WAC only)	AC: 0.25mA~0.75mA, ON/OFF selectable.
<input checked="" type="checkbox"/> OFFSET compensation	Open Circuit: Leakage current offset compensation for WAC, WDC.
<input checked="" type="checkbox"/> Indicator and alarm	PASS: beeps for time as Pass-Hold timer. Fail: Continuously beeps till manually reset. Alarm is for final Fail judge. High/Low Fail (WV, IR, DCR) ARC Fail (WV) GFI Fail (WV, IR) Open/Short Fail (OSC, HFCC) IWT Fail (IWT)
<input checked="" type="checkbox"/> Interlock	2 pins connector, pin1 pull-up to digital +V source with 4.7kohm resistor, and pin 2 tied to digital GND.
<input checked="" type="checkbox"/> Handler interface	36 pins connector, ALL input/output are negative true logic and optically-isolated open collector signals (General-speed photo-coupler used). * All outputs must be pulled-up with 10kohm resistor to +VEXT (external power supply). * All input optic-diode must be series with current limit (10mA±4mA for +3V ~ +26V) circuit.
<input checked="" type="checkbox"/> Remote interface	
<input type="checkbox"/> RS-232	The programming language is SCPI.
<input type="checkbox"/> USB (B-type)	Meet USBTMC.
<input type="checkbox"/> LAN	Supporting 10M/100M Ethernet.
<input checked="" type="checkbox"/> Memory Storage	200 instrument setups, Each setup can be programmed up to 60 steps max. (IWT & IWT Compare 40 steps max.)
<input checked="" type="checkbox"/> USB flash drive (A-type)	Test parameters, result and waveform (BMP) storage. (EXP. function). One memory of test procedure and parameter can be storage/recall. Backup/restore all memory data to USB flash. Support FAT32 format.
<input checked="" type="checkbox"/> Ambient Temperature and Relative Humidity	
<input type="checkbox"/> Specifications range	18 to 28°C (64 to 82°F), ≤ 70% RH.
<input type="checkbox"/> Operable range	0°C to 45°C, 15% to 95% RH@ ≤ 40°C and no condensation.
<input type="checkbox"/> Storage range	-10 to 50°C, ≤ 80% RH.
<input checked="" type="checkbox"/> Power Requirement	
<input type="checkbox"/> Line Input	100Vac ~ 240Vac, 50/60 Hz.
<input type="checkbox"/> Power Consumption	No Load:<150W, Rated Load:<1000W
<input type="checkbox"/> Dimension	428 W x 177 H x 500 D mm / 16.85 x 6.97 x 19.69 inches
<input type="checkbox"/> Weight	< 26 kg / 57.32lbs
<input checked="" type="checkbox"/> Safety	
<input type="checkbox"/> Ground Bond	Less than 100mΩ at 25Amp, 2sec.
<input type="checkbox"/> Hi-Pot L + N to Earth	Less than 15mA at WVAC 1.5kV, 60Hz, 3sec no flashover happen (ARC level<8mA, tested by Chroma 19032).
<input type="checkbox"/> Hi-Pot L + N to Earth	Hi-Pot L + N to Earth: Less than 0.1mA at WVDC 2.2kV, 60sec no flashover happen, ramp time 2sec (ARC level<5mA, tested by Chroma 19032).
<input type="checkbox"/> Insulation L + N to Earth	Greater than 20MΩ at 500V dc, 2sec.

<input type="checkbox"/> Line leakage current	Line leakage current: Less than 3.5mA at 264V Vin max, normal and reverse.
---	---

Note

1. IR full scale of measuring range:
 0.1MΩ~49.9MΩ→full scale=49.9MΩ.
 50MΩ~499MΩ→full scale=499MΩ.
 0.50GΩ~4.99GΩ→full scale=4.99GΩ.
 5.0GΩ~49.9GΩ→full scale=49.9GΩ.
 50GΩ~60GΩ→full scale=60GΩ.
2. Design in Specifications. Validation point is 2.5kV with a 500kΩ resistor.
3. The minimum testing time arrives at 90% output voltage specification (NO load).
 Except Real current, minimum test time is 1s.
4. The maximum measured capacitance ($C_s + C_{offset}$) < 100pF
5. DCR Test Time + DWELL Time ≥ 0.4sec + Switch Time
6. Lx mode and Lx Balance mode require Chroma Transformer Tester 3252 (F/W: ver. 7.90 above).
7. The DCR specifications for firmware version before 2.02 are shown in the table below:

■ DC Resistance measurement (Four terminals)																									
<input type="checkbox"/> Test Signal	DC<10V, 500mA max (design in spec)																								
<input type="checkbox"/> DCR Test Timer	Test Time: 0.1 ~ 999 Sec., and Continue (≤100kΩ) Test Time: 0.5 ~ 999 Sec., and Continue (>100kΩ) DWELL Time: 0.1 ~ 999 Sec., and Off																								
<input type="checkbox"/> Test Range and accuracy	NORMAL MODE(TIME≥ 0.5sec, Hold Range)																								
	<table border="1"> <thead> <tr> <th>Range</th> <th>Test range</th> <th>Measurement Accuracy</th> </tr> </thead> <tbody> <tr> <td>100mΩ</td> <td>10.0mΩ~100.0mΩ</td> <td>± (0.5% of reading + 1.0% of range)</td> </tr> <tr> <td>1Ω</td> <td>0.100Ω~1.000Ω</td> <td>± (0.5% of reading + 0.2% of range)</td> </tr> <tr> <td>10Ω</td> <td>1.00Ω~10.00Ω</td> <td>± (0.5% of reading + 0.05% of range)</td> </tr> <tr> <td>100Ω</td> <td>10.0Ω~100.0Ω</td> <td>± (0.5% of reading + 0.05% of range)</td> </tr> <tr> <td>1kΩ</td> <td>0.100kΩ~1.000kΩ</td> <td>± (0.5% of reading + 0.05% of range)</td> </tr> <tr> <td>10kΩ</td> <td>1.00kΩ~10.00kΩ</td> <td>± (0.5% of reading + 0.05% of range)</td> </tr> <tr> <td>100kΩ</td> <td>10.0kΩ~100.0kΩ</td> <td>± (0.5% of reading + 0.05% of range)</td> </tr> </tbody> </table>	Range	Test range	Measurement Accuracy	100mΩ	10.0mΩ~100.0mΩ	± (0.5% of reading + 1.0% of range)	1Ω	0.100Ω~1.000Ω	± (0.5% of reading + 0.2% of range)	10Ω	1.00Ω~10.00Ω	± (0.5% of reading + 0.05% of range)	100Ω	10.0Ω~100.0Ω	± (0.5% of reading + 0.05% of range)	1kΩ	0.100kΩ~1.000kΩ	± (0.5% of reading + 0.05% of range)	10kΩ	1.00kΩ~10.00kΩ	± (0.5% of reading + 0.05% of range)	100kΩ	10.0kΩ~100.0kΩ	± (0.5% of reading + 0.05% of range)
	Range	Test range	Measurement Accuracy																						
	100mΩ	10.0mΩ~100.0mΩ	± (0.5% of reading + 1.0% of range)																						
	1Ω	0.100Ω~1.000Ω	± (0.5% of reading + 0.2% of range)																						
	10Ω	1.00Ω~10.00Ω	± (0.5% of reading + 0.05% of range)																						
	100Ω	10.0Ω~100.0Ω	± (0.5% of reading + 0.05% of range)																						
	1kΩ	0.100kΩ~1.000kΩ	± (0.5% of reading + 0.05% of range)																						
	10kΩ	1.00kΩ~10.00kΩ	± (0.5% of reading + 0.05% of range)																						
	100kΩ	10.0kΩ~100.0kΩ	± (0.5% of reading + 0.05% of range)																						
FAST MODE(TIME=0FF, TIME<0.5sec, Hold Range)																									
<table border="1"> <thead> <tr> <th>Range</th> <th>Test range</th> <th>Measurement Accuracy</th> </tr> </thead> <tbody> <tr> <td>100mΩ</td> <td>10.0mΩ~100.0mΩ</td> <td>± (1.5% of reading + 2.4% of range)</td> </tr> <tr> <td>1Ω</td> <td>0.100Ω~1.000Ω</td> <td>± (1.5% of reading + 0.6% of range)</td> </tr> <tr> <td>10Ω</td> <td>1.00Ω~10.00Ω</td> <td>± (1.5% of reading + 0.15% of range)</td> </tr> <tr> <td>100Ω</td> <td>10.0Ω~100.0Ω</td> <td>± (1.5% of reading + 0.15% of range)</td> </tr> <tr> <td>1kΩ</td> <td>0.100kΩ~1.000kΩ</td> <td>± (1.5% of reading + 0.15% of range)</td> </tr> <tr> <td>10kΩ</td> <td>1.00kΩ~10.00kΩ</td> <td>± (1.5% of reading + 0.15% of range)</td> </tr> <tr> <td>100kΩ</td> <td>10.0kΩ~100.0kΩ</td> <td>± (1.5% of reading + 0.15% of range)</td> </tr> </tbody> </table>	Range	Test range	Measurement Accuracy	100mΩ	10.0mΩ~100.0mΩ	± (1.5% of reading + 2.4% of range)	1Ω	0.100Ω~1.000Ω	± (1.5% of reading + 0.6% of range)	10Ω	1.00Ω~10.00Ω	± (1.5% of reading + 0.15% of range)	100Ω	10.0Ω~100.0Ω	± (1.5% of reading + 0.15% of range)	1kΩ	0.100kΩ~1.000kΩ	± (1.5% of reading + 0.15% of range)	10kΩ	1.00kΩ~10.00kΩ	± (1.5% of reading + 0.15% of range)	100kΩ	10.0kΩ~100.0kΩ	± (1.5% of reading + 0.15% of range)	
Range	Test range	Measurement Accuracy																							
100mΩ	10.0mΩ~100.0mΩ	± (1.5% of reading + 2.4% of range)																							
1Ω	0.100Ω~1.000Ω	± (1.5% of reading + 0.6% of range)																							
10Ω	1.00Ω~10.00Ω	± (1.5% of reading + 0.15% of range)																							
100Ω	10.0Ω~100.0Ω	± (1.5% of reading + 0.15% of range)																							
1kΩ	0.100kΩ~1.000kΩ	± (1.5% of reading + 0.15% of range)																							
10kΩ	1.00kΩ~10.00kΩ	± (1.5% of reading + 0.15% of range)																							
100kΩ	10.0kΩ~100.0kΩ	± (1.5% of reading + 0.15% of range)																							
** Measurement accuracy is only correct while Zero correction is well performed.																									
Display range up to 500kΩ in 100kΩ range, test range 100kΩ~500kΩmeasuring accuracy: NORMAL MODE : ±(0.5% of reading + 0.5kΩ) (minimum test time is 0.5s)																									
Display range 1.0mΩ to 9.9mΩ in 100mΩ range, test range 1.0mΩ~9.9mΩ measuring accuracy: NORMAL MODE : ± (0.5% of reading + 3.0% of range) FAST MODE : ± (1.5% of reading + 5.0% of range)																									

3. Precautions before Use

The Model 19036 Wound Component EST Analyzer can output up to 6kV high voltage for external test. Accidents may occur or even cause death if using the instrument incorrectly. It is strongly recommended that the following be read and followed carefully to avoid injury and/or death.

1. Electric shock

To prevent electric shock, it is suggested that all operators wear insulated rubber gloves before using the instrument.

2. Grounding

A safety ground terminal is located at the rear of the rear chassis of the instrument; please ensure proper ground exactly has shown. A dangerous condition can occur if ground is loose or becomes disconnected during testing as the chassis may carry a high potential. Anyone touching the device in this case may experience electric shock. Therefore, it is necessary to connect the safety ground terminal to earth properly and securely as Figure 3-1 shows.

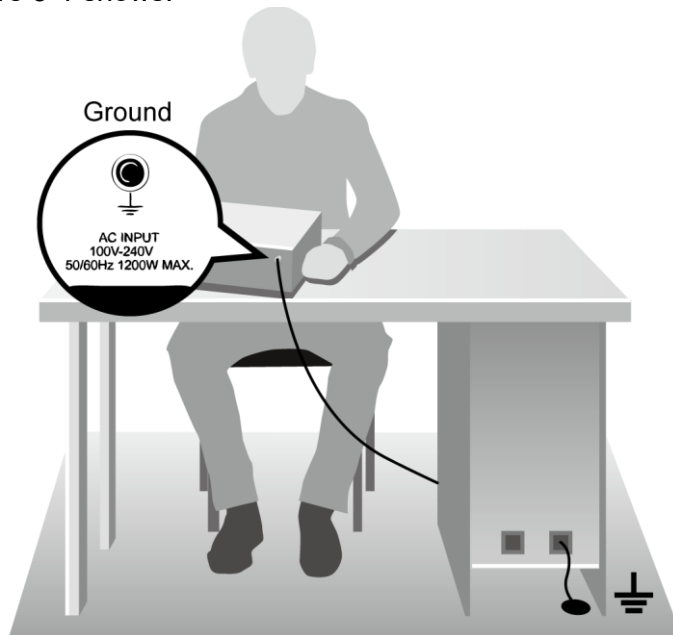

Figure 3-1 Diagram for Safety Grounding

3. Fragile liquid panel

Do not press the front liquid panel heavily or use a sharp object to touch the panel as it may cause the panel to break or display improperly.



4. Handling precautions

The gross weight of the Impulse Winding Tester is about 26kg (57.32lbs). It is recommended to be a two-man lift or use a lifting aid to avoid injury during lifting and transportation.

5. Connecting test cable to HV terminal

It is necessary to check if the test cable on HV terminal is connected at all times and is not loose. When connecting a test unit with an external test cable, connect the RTN/LOW test cable to the test unit first. It is very dangerous if the test cable on HV or RTN/LOW terminal is not connected correctly or falls off as the entire Device Under Test may contain high voltage.

6. Connecting test cable to high voltage output terminal

When the RTN/LOW test cable is connected, follow the steps below to connect the high voltage output cable.

- Press **STOP**.
- Make sure the DANGER indicator is not on.
- Short the test cable of RTN/LOW and HV terminal to make sure there is no voltage output.
- Plug in the high voltage test cable to HV terminal.
- At last connect the RTN/LOW test cable to the DUT (Device Under Test) and then connect the HV test cable.

7. End of test

When the test has ended or Analyzer is no longer in use or is unattended, it is necessary to toggle the power switch to OFF (i.e. to shut down the power) as Figure 3-2 shows.

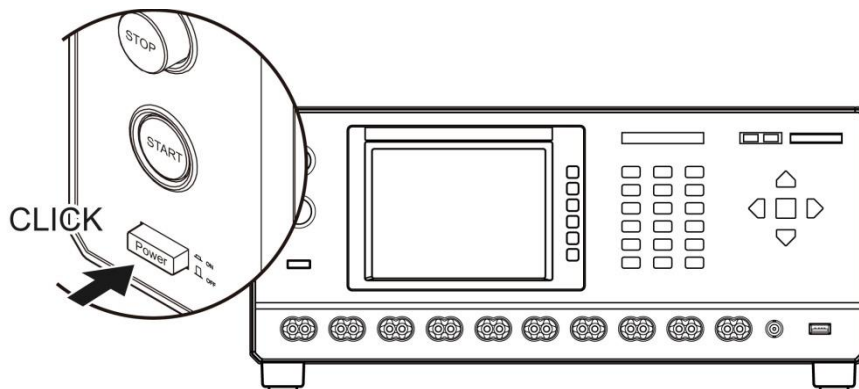

Figure 3-2 Power Switch Off

8. Do not touch hazard areas when the EST Analyzer is in test mode

When the EST Analyzer is in use, it is a very dangerous to touch the areas of DUT, test cable, probe and output terminal that contain high voltage.

- ⚡ CAUTION** : Do not touch the alligator clip on the test cable as Figure 3-3 shows. : When the host is in testing state the insulation of rubber shield on it is : not enough; therefore it is hazardous to touch it.

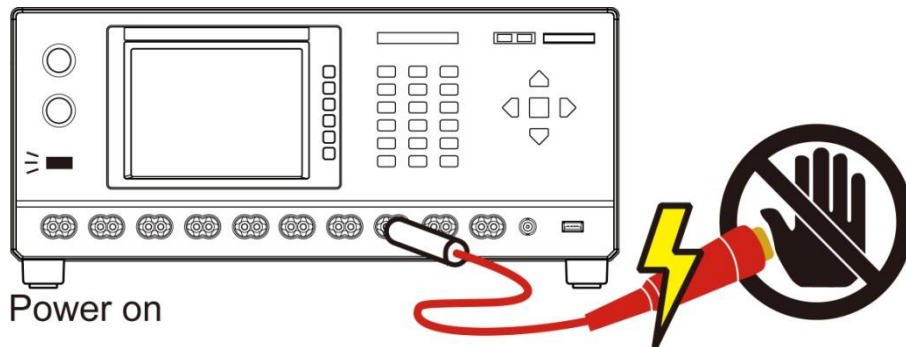

Figure 3-3 No Touch When Outputting High Voltage

<<< **Warning!** When output terminal is cutoff >>>

9. Ensure the test is done

Sometimes the user might need to touch the high voltage areas such as DUT, high voltage test cable or output terminal etc. due to configuration or test required change. In that case, please make sure the following:

- **The power switch is turned off.**
- **Being an insulation resistance test object the DUT after test may contain high voltage; therefore it is necessary to read the description of item 10 and 11 for execution.**

<<< **Warning!** Charging when doing insulation resistance test >>>

10. Charging

When doing insulation resistance test, the DUT, capacitor, test cable, probe and output terminal, even the EST Analyzer itself may contain high voltage. The charged voltage may need some time to discharge completely after turning off the power switch. It is necessary to follow the instruction described above for actions. Do not touch any area that may cause electric shock especially when the power is just turned off.

11. Ensure the charged voltage is fully discharged

The time required for fully discharging the voltage depends on the test voltage applied and the features of DUT. Assuming the high voltage added on the DUT equals the high voltage added to a 0.01 μ F capacitor and paralleled to a 100M Ω resistance circuit. When the test voltage is 1000V, then it requires approximately 3.5 seconds for the voltage that added to test and on DUT to fall to 30V under after turned off the power. For 500V test voltage, it requires about 2.8 seconds. Assuming the time constant of a DUT is already known, the way described above can be used to calculate the time required for voltage falling to 30V under after powered off by timing the time constant multiple to the time decreased to 30V under as Figure 3-4 shows.

$$\text{Formula: } V_0 e^{-t/RC} = V_{IL}$$

$$\text{Ex.: } 1000V \times e^{-t/RC} = 30V$$

$$e^{-t/RC} = 0.03$$

$$-t/RC = \ln 0.03 \quad \square \quad t = 3.5 \text{ Sec}$$

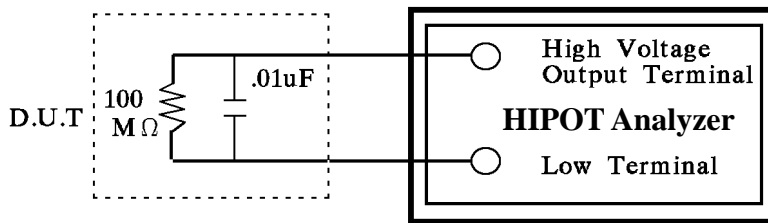

Figure 3-4

12. Remote controlling the EST Analyzer

The EST Analyzer can be remote controlled generally for high voltage output via external control signal. When performing it, it is necessary to follow the control guidelines for safety and precautions.

- Do not allow any accidental high voltage output that may cause hazard.
- When there is high voltage output from the EST Analyzer, do not allow any operator or other personnel to touch the DUT, test cable or probe output, etc.

<<< CAUTION >>>

13. Turning on or off the power switch

Once the power switch is turned off, it needs to wait for a few seconds to turn it on again. Do not power it on and off continuously to avoid occurring errors. It is very dangerous to power it on and off continuously when in high voltage output state in particular. **When turning on or off the power, the high voltage output terminal cannot connect to any object to avoid the hazard caused by abnormal high voltage output.**

14. Other notices

Do not short-circuit the output line, grounding wire, communication cable or other device's grounding wire or AC power to avoid charging the entire EST Analyzer with dangerous voltage. To short-circuit the terminals of high voltage output and RTN/LOW, it is necessary to ground the EST Analyzer chassis to earth properly.

<<< Emergency Case >>>

15. Process for emergency case

To avoid causing bigger hazard when in emergency situations like electric shock, DUT or EST Analyzer burnout, please perform the steps below:

- **First cutoff the power switch.**
- **Second unplug the power cord.**

<<< Resolving Problem >>>

16. Problems occurred

Problems occurred in the following situation are very dangerous. The output terminal may still have high voltage output even the **STOP** key is pressed; therefore, the user should be extremely careful when dealing with it.

- The DANGER LED indicator keeps on when **STOP** key is pressed.
- The DANGER LED indicator is on but the voltage meter has no readings.

When the above situation occurs, shut down the power and unplug the AC power cord immediately. Do not use the device again as failure is awfully hazardous. Please send the hardware back to Chroma or its distributor for repair service.

17. DANGER Indicator failure

When pressing **START** key the voltage meter has readings but the DANGER LED indicator is still off, it means the indicator may be broken. Please power off the hardware and replace it with another device, then send the broken one back to Chroma or its distributor for repair service.

18. Be aware of the following when using the EST Analyzer for long hour in normal state

If the tested leakage current is maximum power (AC: 500VA (5kV, 100mA), be aware of its temperature change. If the ambient temperature exceeds 40°C, stop using it temporarily until the temperature drops to normal. Be sure to check the room temperature before use.

19. Applicable AC INPUT for EST Analyzer is 100Vac ~ 240Vac, 50/60 Hz

Be sure to replace the fuse when the power cord is unplugged to avoid electric shock. Use a flat screwdriver to pry the fuse holder inside the power socket and remove the fuse to replace with a new one by pushing it in gently, and then push the power socket back to its position.

 **WARNING** : Be sure to use the fuse with correct specification or it may cause hazard.

20. This EST Analyzer is normally operated under AC power

If the power supply is unstable, it may cause the device to work inaccurately or abnormally. Thus, please use appropriate equipment such as a power supply regulator to convert it to a suitable one.

21. This EST Analyzer draws large current instantly

When the device to be tested draws a great deal of current, the current (about 10amp) may flow in for more than 10ms before judging for the defect item and cutting off the output current. The same situation may occur before test, thus it is necessary to watch out the power cord capacity and the connecting cables used for other instruments or devices.

22. Storage

The storage temperature for the EST Analyzer is from -10°C to 50°C, 80% RH. If it is not in use for a long time, please pack it with its original package for storage. For proper test and safety measures, do not place the EST Analyzer under direct sunlight, high temperature, trembling, humid or dusty area.

23. Warming up

The EST Analyzer is activated when power is on; however, in order to meet the specifications for accuracy please warm it up for 15 minutes or above.

24. Warning label during test

**“DANGER – HIGH VOLTAGE TEST IN PROGRESS, UNAUTHORIZED PERSON
KEEP AWAY”**

25. Keep test cables away from panel

When operating the device, be sure to keep the high voltage wire or DUT at least 30 cm away from the panel to avoid high voltage discharge interfering the display.

26. Precautions for connecting automated device

- The grounding system of EST Analyzer and automatic device should be connected together.
- Install anti-interference iron power cores winding at least 1 circle for the two ends of high voltage wire and RTN/LOW test cable.
- High voltage wire and RTN/LOW test cable must be separated from the control cable.
- High voltage wire and RTN/LOW test cable must keep appropriate distance from the device/panel.

4. Operation

4.1 Front Panel

The front panel is divided into several easy-to-use areas. This section introduces each control item and the information displayed on LCD.

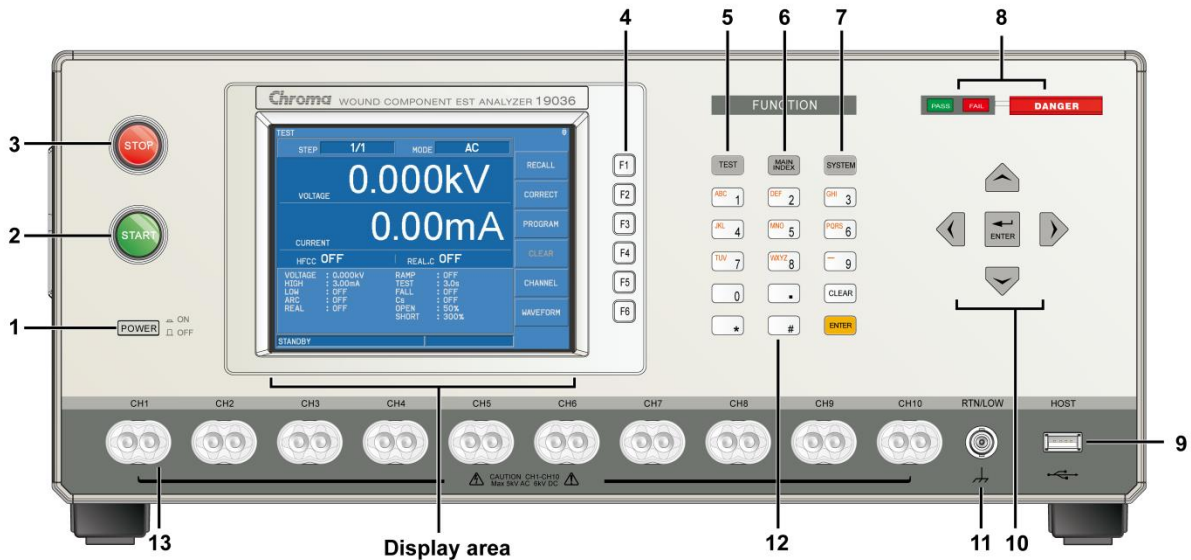
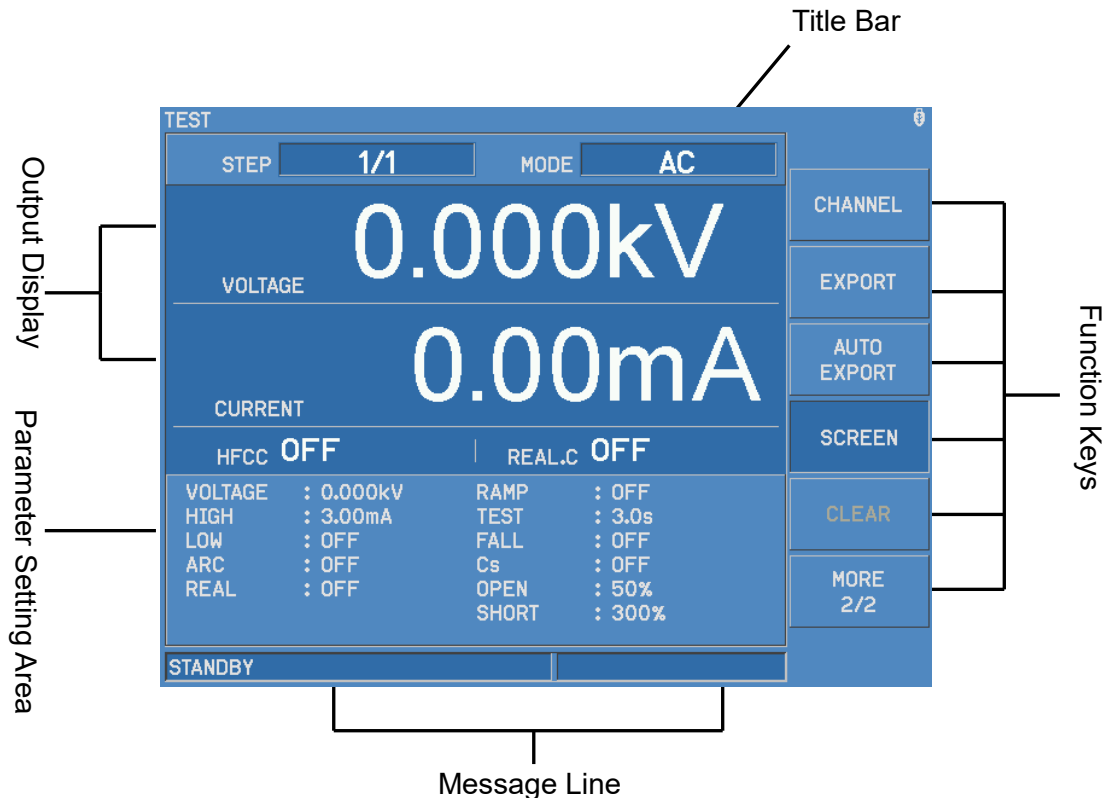
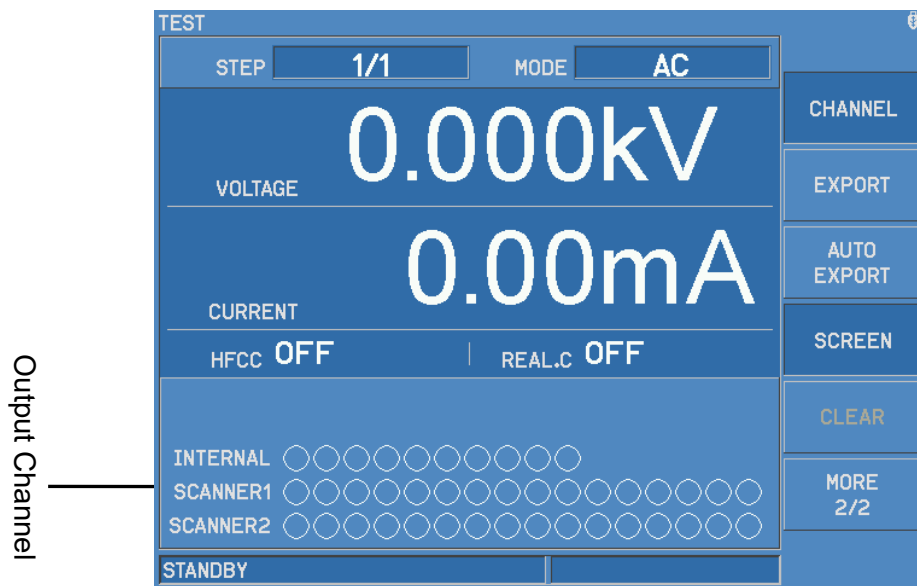

Figure 4-1 Front Panel

■ Display Area Zoom In





- Title Bar:** The text here indicates the current setting in use or the test mode the device is in.
- Output Display:** The text in this area shows the output and readings from current device.
- Parameter Setting:** The text in this area shows the parameter settings of current device.
- Function Keys:** Different function key descriptions will appear in different screen and the mapping function keys are on the right of LCD. If the description is blank, it indicates the mapping function key is invalid.
- Message Line:** This line of text instructs the setting method, range and test time.
- Output Channel:** Press Function key [CHANNEL] and this area will change to Output Channel from Parameter Setting. This function is only applicable to AC, DC, IR, DCR, Δ/Y DCR, OSC, Lx, and EXTERIOR CONNECT test programs.

Press Function key [LIST] the screen will change from single test parameter and result to multiple parameters and results as the figure shown below.



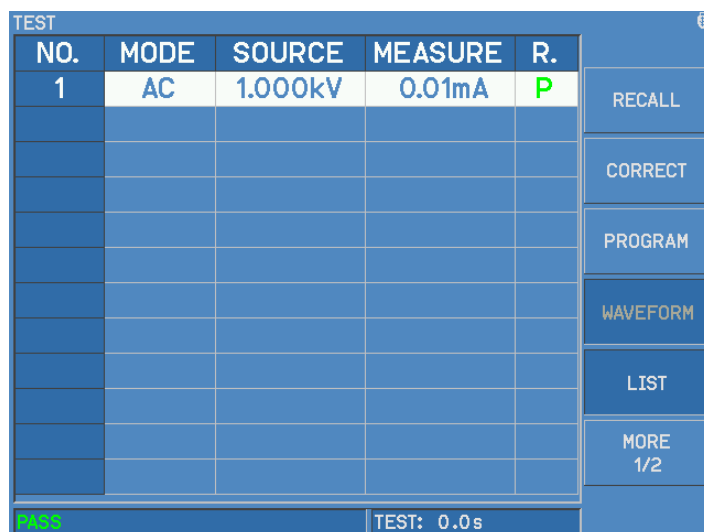

■ LIST Display Area

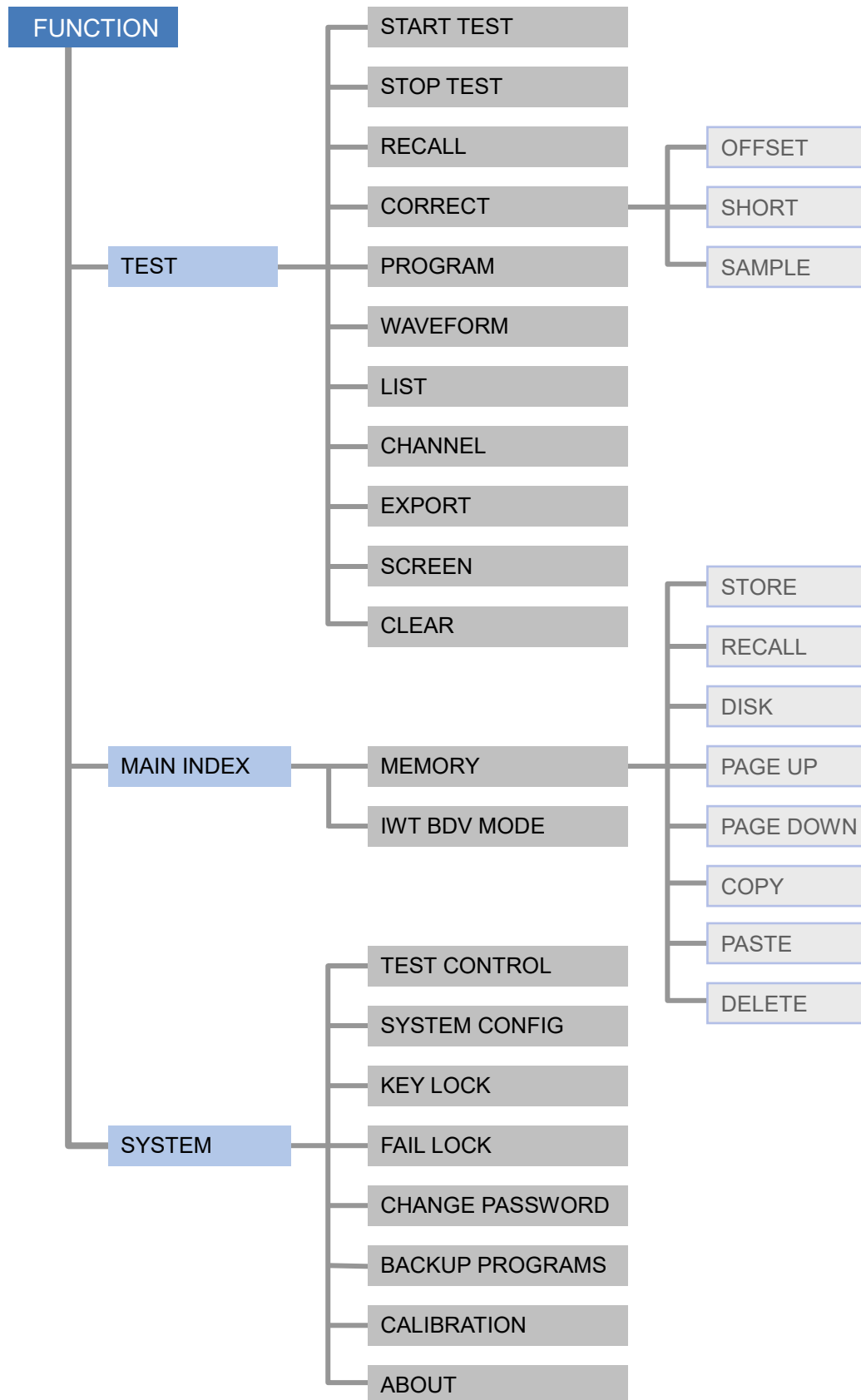

Function Key Flow Chart



Buttons

- (1) **Power Switch** : It is the AC power switch of the Wound Component EST Analyzer. Be sure to read Chapter 3 *Precautions before Use* before using this switch.
- (2) **START Key** : It is the test activation key. The EST Analyzer is in test state when pressed, which means there is output on test terminal and the judging functions are activated at the same time.
- (3) **STOP Key** : It is the reset key. When pressed the EST Analyzer will cutoff output immediately or return to ready-to-test state and clear all judgments.
- (4) **Function Key** : The functions are varied when in different screen. The mapping function names are listed on the right of LCD. If the mapping area is blank it indicates the function key is invalid.
- (5) **TEST Key** : Press this key in any screen can return to [TEST] mode.
- (6) **MAIN INDEX** : It is the key to manage the test. Press this key can enter into the memory management screen for saving and deleting test procedures.
- (7) **SYSTEM Key** : It is the key to enter the system setting screen.
- (8) **Indicator** : It is the TESTING LED and judgment LED indicators.
- (9) **HOST** : It can be used as extended memory with common USB flash drive on the market.
- (10) **Cursor Keys** :     are the cursor movement keys for setting functions or editing test procedures. Press **ENTER** to confirm the entry.
- (11) **RTN/LOW** : It is common test terminal as well as the reference terminal for high voltage test which is the low potential end. It is almost equivalent to chassis grounding terminal.
- (12) **Data Entry Keys/ Program Keys**
- [0][.]~[9] [*] [#] : The numeric/character keys to input various programs (value or English alphabet.)
 - [ENTER] : It is the confirmation key. Press this key to confirm the entered value of program.
 - [CLEAR] : It is the clear key. Press this key to clear the error data when entering the program.
- (13) **HV** : It is the high potential end for high voltage output. It is very dangerous especially when the DANGER light is on which means there is high voltage output. Do not touch it.

4.2 Rear Panel

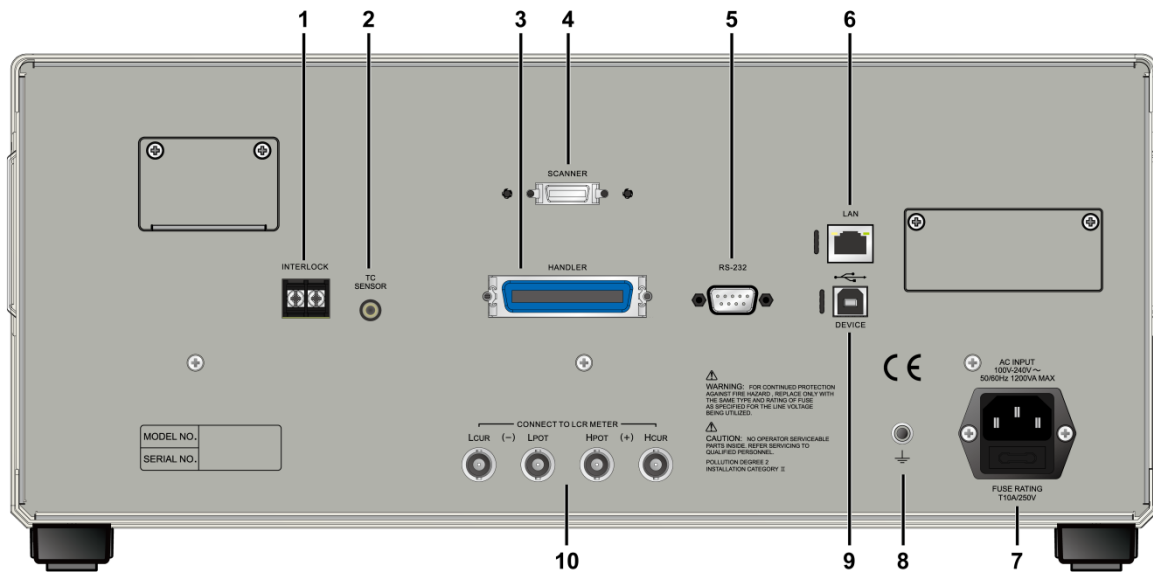

Figure 4-2 Rear Panel







- (1) **INTER LOCK** : High voltage output is enabled when these two terminals are short-circuited.
- (2) **TC Interface** : This connector is the interface for connecting temperature probe. See 4.7.4 *Temperature Measurement* for detail usage.
- (3) **HANDLER Interface** : This connector is for the HANDLER interface. See Chapter 5 *HANDLER Interface* for detail usage.
- (4) **SCAN Interface** : This connector is the interface for connecting the EST Analyzer to A190362 16 HV External Scanning Box.
- (5) **RS232 Interface** : This connector is the interface for connecting the RS232 interface card on PC.
- (6) **LAN Interface** : This connector is the interface for connecting the LAN interface on PC.
- (7) **AC LINE** : It contains a three-wire AC power socket and a fuse holder. The AC power required by the EST Analyzer is supplied by this power socket. For detail specification of fuse, please see Chapter 3 *Precautions before Use* or the instruction on the rear panel.
- (8) **GND Terminal** : It is the safety grounding terminal. Please use an appropriate tool to connect it to earth properly. If it is not properly grounded, the EST Analyzer chassis may contain high voltage when the power circuit or any device's cable is shorted with the grounding terminal, and it is very dangerous as anyone who touches it may cause electric shock incident. Therefore, the safety ground terminal must connect to earth properly.
- (9) **DEVICE Interface** : This connector is the interface for connecting the USB terminal on PC.
- (10) **BNC Terminals** : These are the BNC terminals to connect the Transformer Tester.



4.3 Notices before Use and Operating Procedure

1. Before plugging in the AC power cord, make sure the power in use matches the power indicated on the rear panel and the switch is OFF.
2. Read the precautions described in Chapter 3 *Precautions before Use* carefully and keep them in mind before power-on the EST Analyzer.
3. Once the EST Analyzer is powered on, it will start self-test. If any abnormal occurs, turn off the power switch immediately and unplug the power cord.

4.4 Icon Indicator on Title Bar

When the following occurs, an icon indicator will appear on the title bar as circled in red in the figure shown below.

Icon	Description
	Remote command queue has error message. Use “:SYSTem:ERRor[:NEXT]?” to read it.
	In remote state.
	The defect product is locked.
	The keyboard is locked.
	The USB flash drive is working.
	It is able to use a USB flash drive.

When in the analyzer is in ready state, insert a USB flash drive, an icon indicator will appear on the title bar to show the USB flash drive is inserted successfully. Press  and  to save the screen dump to the USB flash drive.

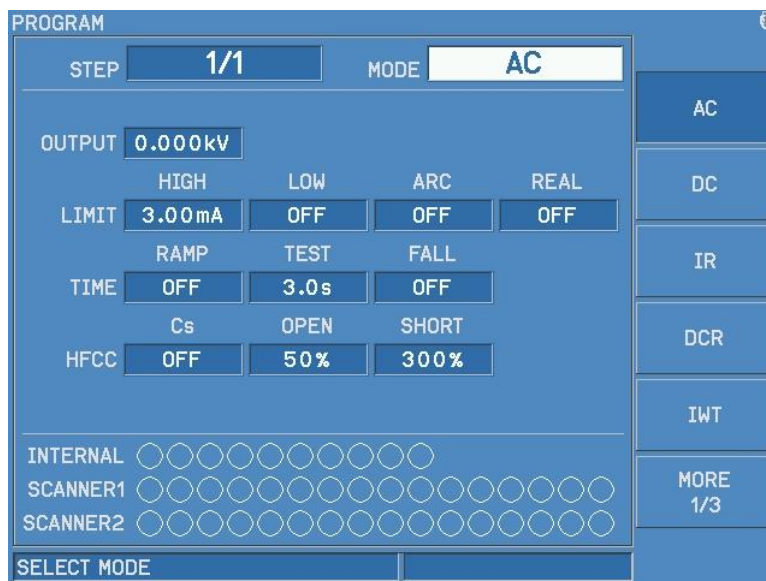

4.5 Setting the SYSTEM

4.5.1 Entering the SYSTEM Setting Screen

Press **SYSTEM** in any screen will show the following:

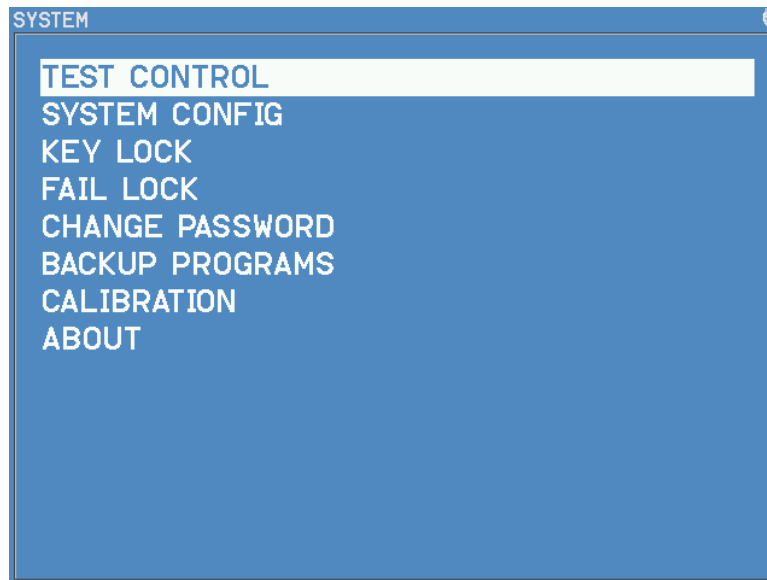

Use the **Cursor Key** **▲** **▼** to move the highlight to the item desired. Press **ENTER** to go to the setting screen of selected function.

Table 4-1 List of System Setting Parameters

Setting Items	Description
TEST CONTROL	It sets the related parameters for test.
SYSTEM CONFIG	It sets the system related parameters.
KEY LOCK	It sets the keyboard lock function.
FAIL LOCK	It locks the keyboard when a failure product is detected.
CHANGE PASSWORD	It changes the user's password.
BACKUP PROGRAMS	It backups the setting data in PROGRAM menu.
CALIBRATION	It sets the calibration related function.
ABOUT	It shows the version related information.

4.5.2 Setting TEST CONTROL

In SYSTEM SETUP screen, move the highlight to TEST CONTROL and press **ENTER** to go to TEST CONTROL setting screen as shown below:

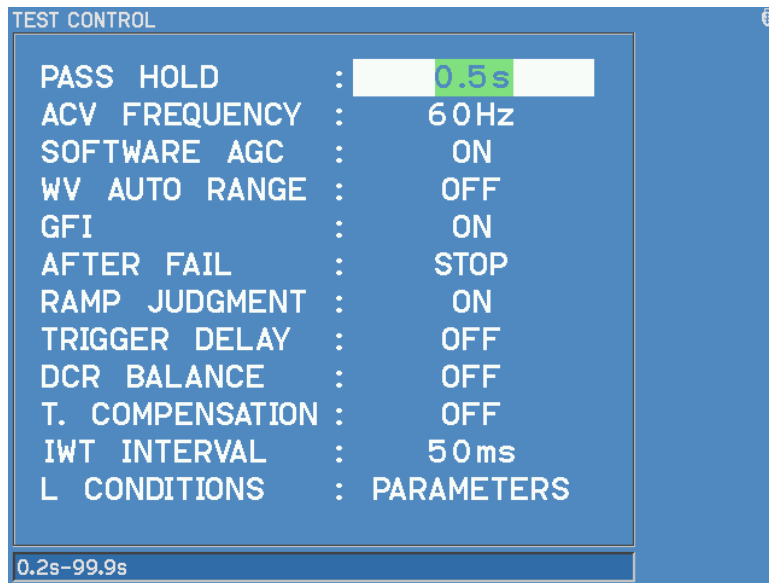

When in TEST CONTROL screen, press **▲** **▼** to move the highlight to the item to be set and press numeric keys or Function key **F1** **F2** **F3** **F4** **F5** **F6** to set the mapped functions.

Table 4-2 Setting Items of TEST CONTROL

Setting Items	Range	Default	Description
PASS HOLD	0.2s~99.9s	0.5s	It sets the time for the beeper to sound when the DUT is judged as PASS.
ACV FREQUENCY	50Hz / 60Hz	60Hz	It sets the frequency of output voltage when performing AC withstand voltage test.
SOFTWARE AGC	ON/OFF	ON	It sets the software AGC function to be on or off.
WV AUTO RANGE	ON/OFF	OFF	It sets the low range auto change function for withstand voltage test to be on or off.
GFI	ON/OFF	ON	It sets the Ground Failure Interrupt function to be on or off. See 4.5.3 for details.
AFTER FAIL	CONTINUE/ STOP	STOP	It sets the action after the test step is judged as FAIL. When set to CONTINUE, it won't stop test after detected FAIL. It will continue the steps afterwards. When set to STOP, it will stop test after detected FAIL and it is necessary to press STOP first and follow by START to begin the test.
RAMP JUDGMENT	ON/OFF	ON	When set to ON, it will judge the high limit during ramp time when in DC mode. When set to OFF, it won't judge the high limit during ramp time when in DC mode.
TRIGGER DELAY	0 (OFF), 10ms~9999ms	OFF	It sets the time delayed after pressing the START key to begin the test.
DCR BALANCE	0(OFF), 0.1mΩ~2MΩ	OFF	When all steps are done, if the difference of maximum and minimum DCR is larger than the DCR Balance setting, it is judged as Balance Fail (shows on the message line.)
T. COMPENSATION			It sets the temperature compensation. (The setting is invalid here. Use the submenu to

			modify the settings and see section 4.7.4.2 for detail description.)
IWT INTERVAL	50ms~160ms	50ms	It sets the time for IWT interval.
L CONDITIONS			It sets the inductance parameters for Transformer Tester. (This setting is only valid when in the submenu. See section 4.5.4 for detail description.)

Notice

When the IWT INTERVAL parameter is edited, redo SAMPLE GET before testing.

4.5.3 Setting GFI (Ground Fault Interrupt)

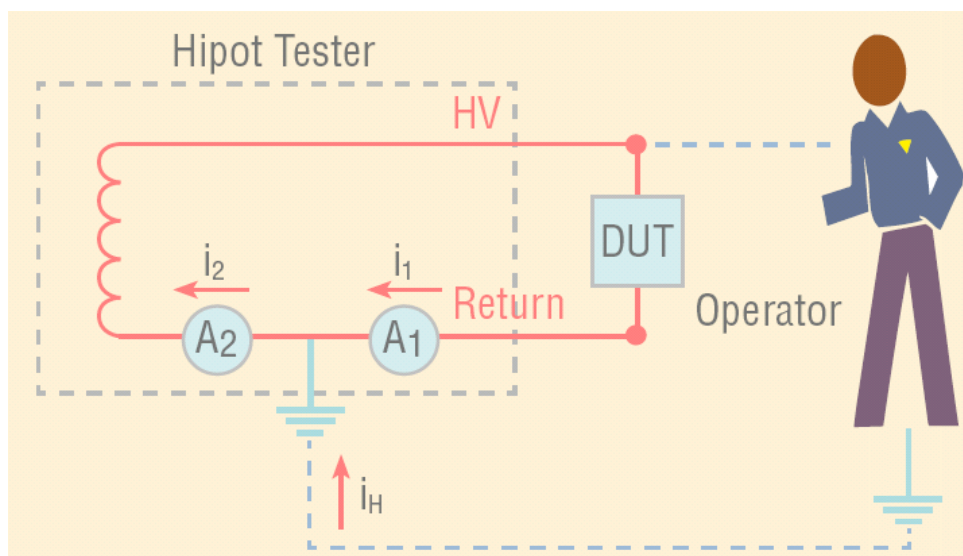

When the operator contacts the high voltage end inadvertently, a current i_H will generate and flow through the human body.

$$i_2 = i_1 + i_H$$

When i_H is higher than GFI current (0.5mA), cutoff the high voltage output to guard the safety of operator.

CAUTION

As the figure shown below, when AC high voltage outputs, the high voltage path or the stray capacitance of GND_EARTH on DUT will generate leakage current i_H and a GFI FAIL will create when the leakage current meets the GFI level ($i_H > 0.5mA$). When performing the test, it is necessary to diminish the GND_EARTH contact area for high voltage cable and DUT to reduce the impact caused by leakage current.

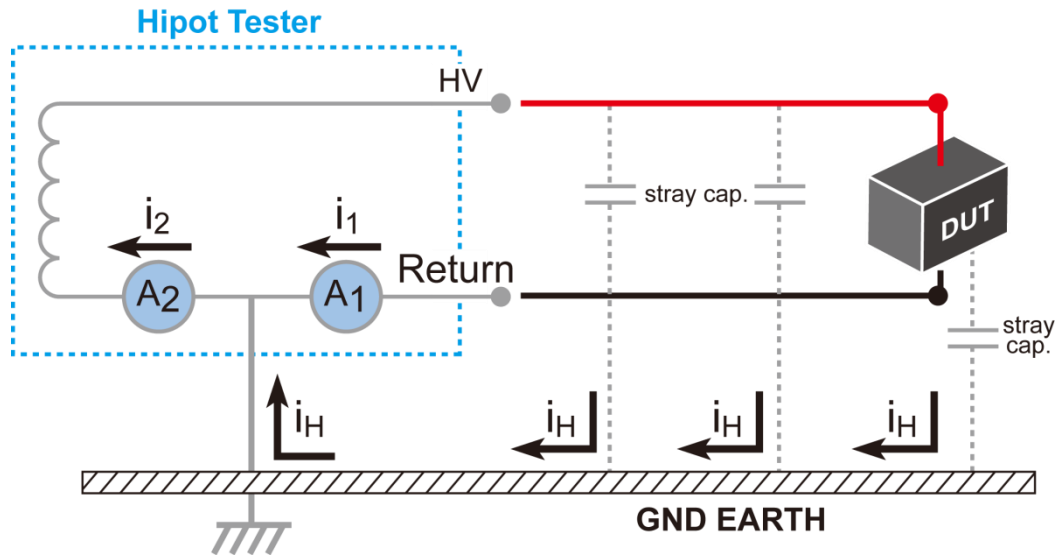

4.5.4 Setting L CONDITIONS

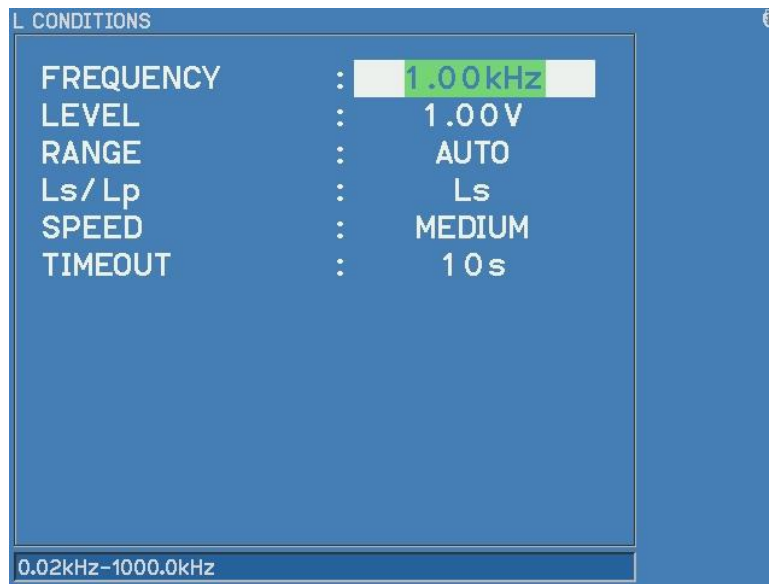

Setting Items	Range	Default	Description
FREQUENCY	0.02kHz~1000.0kHz	1.00kHz	It sets the measurement frequency.
LEVEL	0.01V~2.00V	1.00V	It sets the measurement voltage.
RANGE	AUTO,1,3,5,7,8,10	AUTO	It sets the measurement range.
Ls/Lp	Ls/Lp	Ls	It sets the measurement to series or parallel inductance.
SPEED	SLOW/MEDIUM/FAST	MEDIUM	It sets the measurement speed.
TIMEOUT	1s~300s	10s	It sets the timeout for communication.

4.5.5 Setting SYSTEM CONFIG

In SYSTEM SETUP screen, move the highlight to SYSTEM CONFIG and press **ENTER** to go to the SYSTEM CONFIG setting screen as shown below:

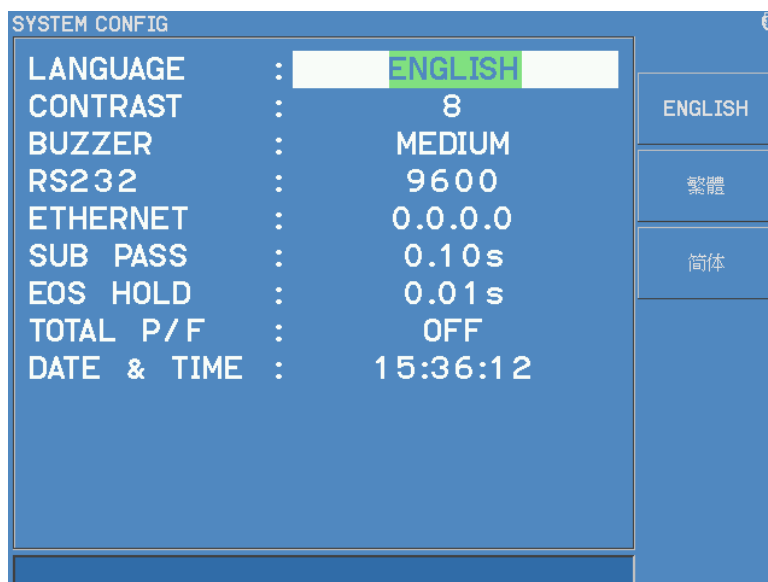

When in SYSTEM CONFIG screen, press **▲** **▼** to move the highlight to the item to be set and press the numeric key or Function key **F1** **F2** **F3** **F4** **F5** **F6** to set the mapped functions.

Table 4-3 Setting Items of SYSYTEM CONFIG

Setting Items	Range	Default	Description	
LANGUAGE	ENGLISH/ Traditional Chinese/ Simplified Chinese	ENGLISH	It sets the display language.	
CONTRAST	1 - 16	8	It adjusts the LCD brightness.	
BUZZER	HIGH / MEDIUM /LOW / OFF	MEDIUM	It adjusts the buzzer volume.	
RS232	BUND RATE	9600/19200/38400/57600/115200	9600	It sets the transmission baud rate of RS232 interface.
	FLOW CONTROL	NONE/HARDWARE	NONE	It sets if enable hardware FLOW CONTROL.
ENTERNET	DYNAMIC IP / STATIC IP	DYNAMIC IP	It sets the IP address of LAN interface. If DYNAMIC IP is selected, the IP is specified by PC and the IP is set by the host if STATIC IP is selected.	
SUB PASS	0.01s ~ 0.5s	0.10s	Main step is the time for conducting SUB STEP during PASS. When Sub Step is skipped without test, Handler Board will send out Step Pass signal and the duration is determined by this setting.	
EOS HOLD	0.01s ~ 0.5s	0.01s	It sets the time hold for end of step.	

TOTAL P / F	ON/OFF	OFF	It sets if sending out PASS/ FAIL signal from the Handler on the rear panel after all test steps are done.
DATE & TIME	NONE	NONE	It sets the time on the host.
L COMBINE	DISABLE/ENABLE	DISABLE	It sets if connecting the transformer tester.
WITH SCANBOX	DISABLE/ENABLE	DISABLE	When set to ENABLE, the host will set CH9 to high voltage output and CH10 to low voltage output automatically in order to connect to SCANBOX.

Notice

When the LANGUAGE is reset, it is necessary to reboot the EST Analyzer to display the set language.

CAUTION

The host will automatically set CH9 to high voltage output and CH10 to low voltage output when the function of WITH SCANBOX is enabled. Refer to the SCANBOX User's Manual to connect the host CH9 high voltage output to the SCANBOX high voltage input and the host CH10 low voltage output to the SCANBOX low voltage input correctly.

4.5.6 Setting KEY LOCK

The way to set KEY LOCK:

In SYSTEM SETUP screen, move the highlight to KEY LOCK and press **ENTER** to go to KEY LOCK setting screen as shown below:

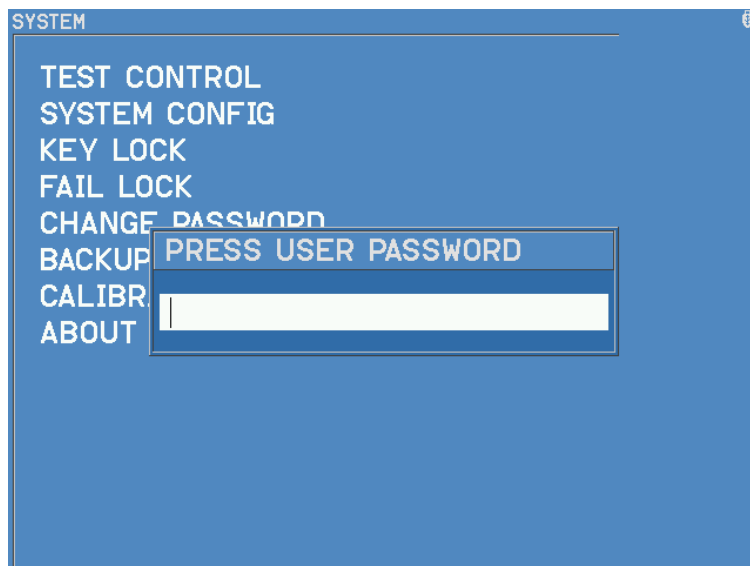

1. In KEY LOCK screen, press numeric keys to enter the PASSWORD (the default is 0000.)
2. Press **ENTER** will prompt a selection window to select if locking RECALL MEMORY. The users can use **OFF**, **ON** to select if locking the function of MEMORY RECALL as

- well.
- When KEY LOCK is ON, the locked function will show in light gray. The “CORRECT”, “PROGRAM” and “STORE”, “DELETE”, “COPY”, “PASTE”, “MOVE UP”, “MOVE DOWN” of MEMORY in [MAIN INDEX] as well as the “TEST CONTROL”, “FAIL LOCK”, “CHANGE PASSWORD”, “CALIBRATION” in [SYSTEM] all cannot be entered for setting.
 - If RECALL LOCK ON is selected when setting KEY LOCK, the MEMORY function under MAIN INDEX is also invalid.

The way to release KEY LOCK:

To release KEY LOCK, press **SYSTEM** to select KEY LOCK as shown below:

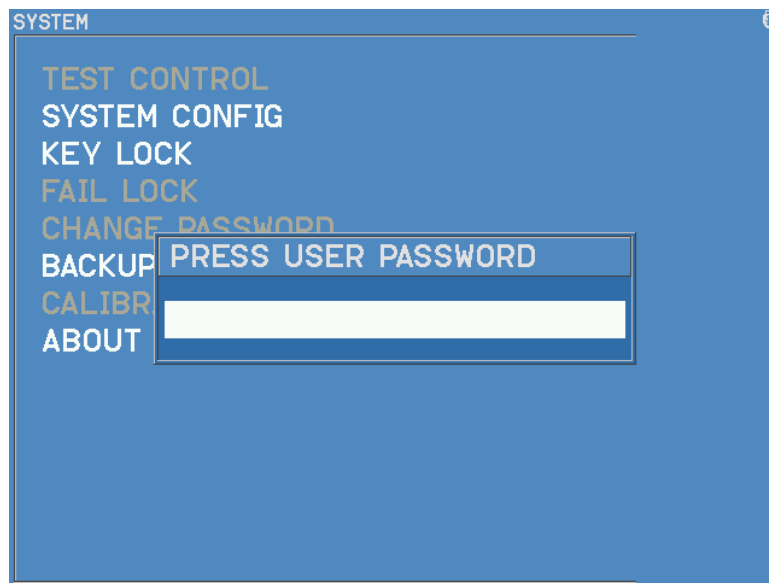

Use numeric keys to enter the PASSWORD and press **ENTER** again, the text of “KEY LOCK” will return to normal color to indicate the KEY LOCK function has been disabled.

4.5.7 Setting FAIL LOCK

The way to set FAIL LOCK:

In SYSTEM SETUP screen, move the highlight to FAIL LOCK and press **ENTER** to go to FAIL LOCK setting screen as shown below:

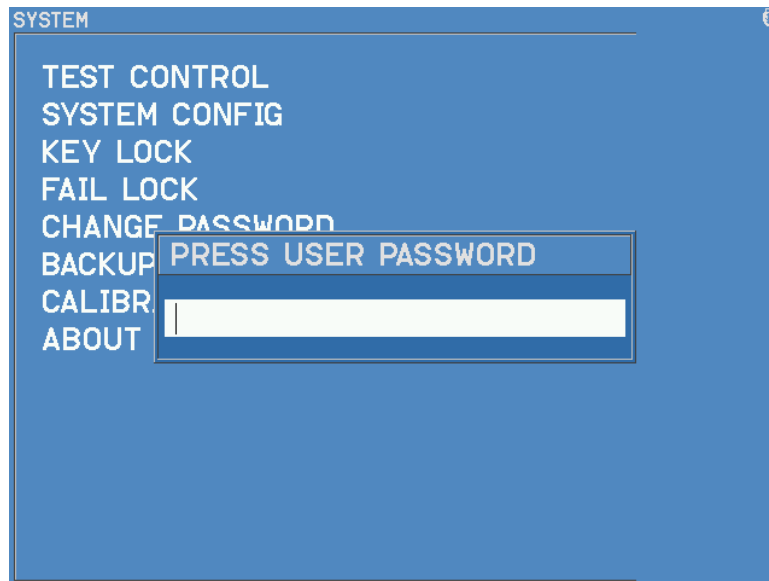

1. In FAIL LOCK screen, press numeric keys to enter the PASSWORD (the default is 0000.)
2. When FAIL LOCK is ON, the locked function will show in light gray. The “RECALL”, “CORRECT”, “PROGRAM” and the “MEMORY” under [MAIN INDEX] as well as “TEST CONTROL”, “KEY LOCK”, “CHANGE PASSWORD”, “CALIBRATION” in [SYSTEM] all cannot be entered for setting.
3. When FAIL LOCK is ON, if the test result is FAIL, Function key [CLEAR] has to be pressed for inputting FAIL LOCK PASSWORD to clear the FAIL status and then continue the test.
4. It will remain in FAIL LOCK state after rebooted. Function key [CLEAR] has to be pressed for inputting FAIL LOCK PASSWORD to clear the FAIL status and then continue the test.

The way to release KEY LOCK:

To release FAIL LOCK, press **SYSTEM** to select FAIL LOCK as shown below:

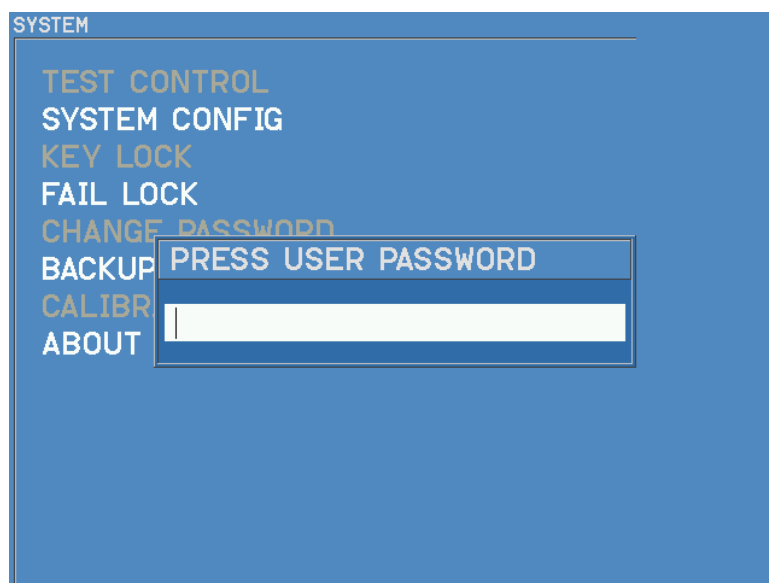

Use numeric keys to enter the PASSWORD and press **ENTER** again, the text of “FAIL LOCK” will return to normal color to indicate the FAIL LOCK function has been disabled.

4.5.8 Changing PASSWORD

Setting password for KEY LOCK:

In SYSTEM SETUP screen, move the highlight to CHANGE PASSWORD and press **ENTER** to go to CHANGE PASSWORD screen as shown below:

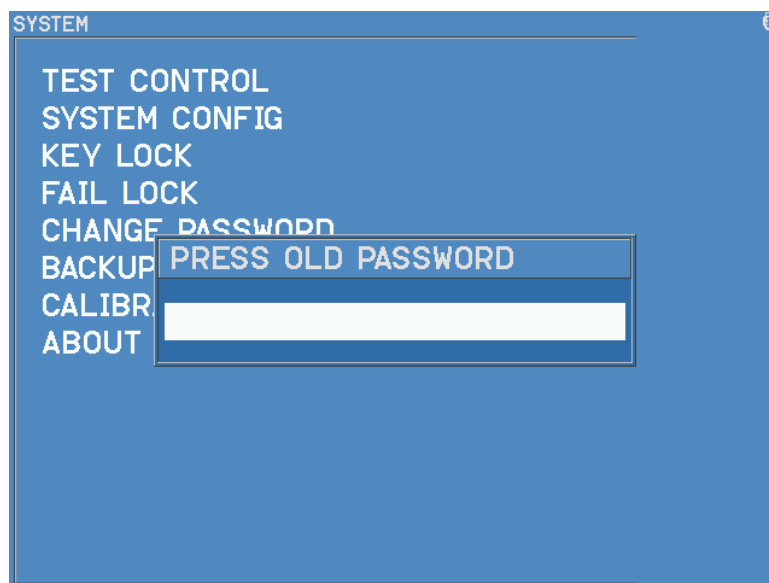

1. Use numeric keys to enter the PASSWORD (enter 0000 if the PASSWORD hasn't been set.) Press **ENTER** and a “PRESS NEW PASSWORD” window will appear.
2. Use numeric keys to enter NEW PASSWORD (maximum 10 characters) and press **ENTER**, a “PRESS NEW PASSWORD AGAIN” window will appear.
3. Use numeric keys to enter the NEW PASSWORD again and press **ENTER** to complete the PASSWORD change.

4.5.9 Using USB to Backup Host Memory

Perform the steps below if there is a need to import or export all test parameters from or to the USB flash drive.

1. Insert the USB flash drive into the HOST connector on the front panel. Please make sure the USB format is FAT32.
2. Press **SYSTEM** and select BACKUP PROGRAMS as the figure shown below.

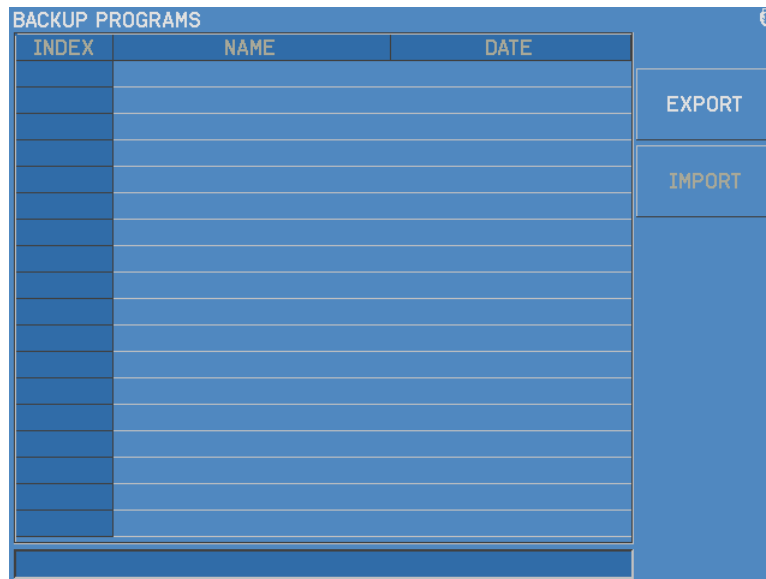

Use the Function Key [EXPORT] or [IMPORT] to export or import test parameters from or to the memory.



This function cannot be processed for a single memory. If it is necessary to process a single memory, please use the [MEMORY] function.

4.6 Managing Programs and TEST CONTROL Memory

19036 has **200 sets** of memory and each of them can save 60 test steps except maximum 40 sets for IWT plus IWT COMPARE. Each memory has programs, TEST CONTROL parameters and the name of the memory.

4.6.1 Entering the Memory Screen

1. Press **MAIN INDEX** in any screen will appear the following:

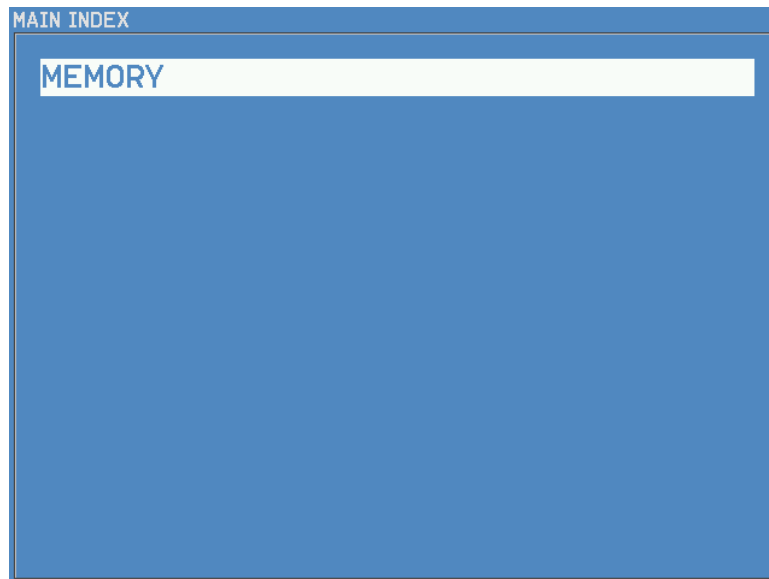

2. Press **ENTER** to get in Memory mode as shown below.

MEMORY			
INDEX	STEPS	NAME	
1	1	TEST001	STORE
2	1	TEST002	
3	1	TEST003	
4	0		RECALL
5	0		
6	0		
7	0		DISK
8	0		
9	0		
10	0		PAGE UP
11	0		
12	0		
13	0		PAGE DOWN
14	0		
15	0		
16	0		MORE 1/3
17	0		
18	0		

3. Use **▲▼** to move the highlight to the memory desired for process. Use the Function key **[MORE 1/2]** to switch to store, recall, delete, copy or paste the memory.
4. Press **PAGE UP** or **PAGE DOWN** to change the page for memory index.
5. The value of **STEPS** indicates the number of test steps included in the memory.

4.6.2 Saving the Memory

Follow the steps below to save the set programs into memory:

1. Use **▲▼** to move the highlight to the memory to be saved and press Function key **[STORE]**.

MEMORY			
INDEX	STEPS	NAME	
1	1	TEST001	STORE
2	1	TEST002	
3	1	TEST003	
4	0		RECALL
5	0		
6	0		
7	0		DISK
8	0		
9	0		
10	0		PAGE UP
11	0		
12	0		
13	0		PAGE DOWN
14	0		
15	0		
16	0		MORE 1/3
17	0		
18	0		

- When the cursor highlight is reversed, use numeric or character keys to input the memory name. Press the same number or letter repeatedly can cycle between the number and English letter case for display.
- Once entered a character, the cursor will move to next position for input automatically.
- Press **ENTER** to complete the task.

⚡ CAUTION : The data will be overwritten if there is data in the memory name. Be sure to confirm it before saving.

4.6.3 Recalling the Memory



Follow the steps below to recall the programs stored in memory:

- Use **▲▼** to move the highlight to the memory to be recalled and press Function key **[RECALL]**.

MEMORY			
INDEX	STEPS	NAME	
1	3	Test001	YES
2	2	Test002	
3	3	Test003	
4	0		NO
5	0		
6	0		
7	0		<div style="border: 1px solid black; padding: 5px; margin: 10px auto; width: 80%;"> <p>RECALL</p> <p>RECALL 2 MEMORY?</p> </div>
8	0		
9	0		
10	0		
11	0		
12	0		
13	0		
14	0		
15	0		
16	0		
17	0		
18	0		

- A recall confirmation dialog box is prompted. Press **[YES]** to confirm it or **[NO]** to cancel it.

MEMORY			
INDEX	STEPS	NAME	
1	1	TEST001	COPY
2	1	TEST002	
3	1	TEST003	
4	0		PASTE
5	0		DELETE
6	0		
7	0		
8	0		PAGE UP
9	0		PAGE DOWN
10	0		
11	0		
12	0		MORE
13	0		2/3
14	0		
15	0		
16	0		
17	0		
18	0		

- The highlight of selected program will turn to green and then use   to move the highlight to the position for pasting the program, press Function key [PASTE]. Enter the memory name and press **ENTER** to save it.

MEMORY			
INDEX	STEPS	NAME	
1	1	TEST001	COPY
2	1	TEST002	
3	1	TEST003	
4	0		PASTE
5	0		DELETE
6	0		
7	0		
8	0		PAGE UP
9	0		PAGE DOWN
10	0		
11	0		
12	0		MORE
13	0		2/3
14	0		
15	0		
16	0		
17	0		
18	0		

MEMORY		
INDEX	STEPS	NAME
1	1	TEST001
2	1	TEST002
3	1	TEST003
4	0	
5	0	
6	0	
7	0	
8	0	
9	0	
10	0	
11	0	
12	0	
13	0	
14	0	
15	0	
16	0	
17	0	
18	0	

CANCEL

MEMORY		
INDEX	STEPS	NAME
1	1	TEST001
2	1	TEST002
3	1	TEST003
4	1	COPY003
5	0	
6	0	
7	0	
8	0	
9	0	
10	0	
11	0	
12	0	
13	0	
14	0	
15	0	
16	0	
17	0	
18	0	

CANCEL

4.6.6 Deleting the Memory

Follow the steps below to recall the programs stored in memory:

1. Use ▲ ▼ to move the highlight to the memory to be recalled and press Function key [DELETE].

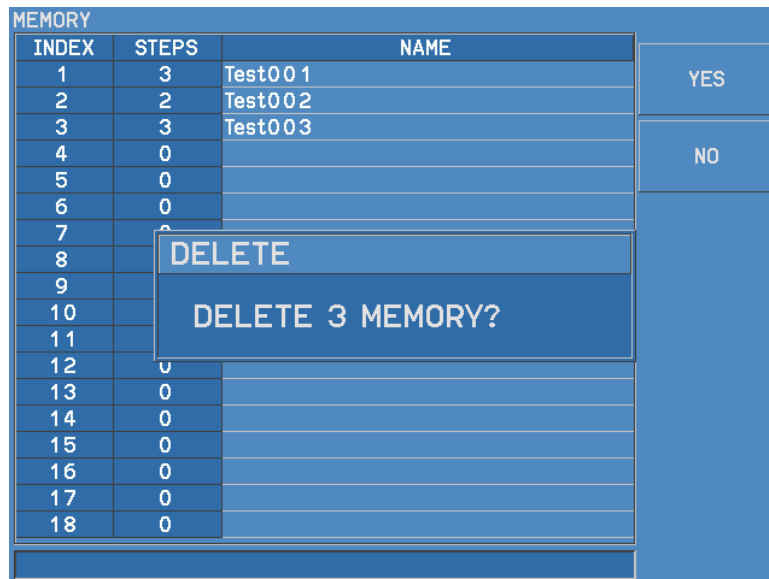

2. A recall confirmation dialog box is prompted. Press [YES] to confirm it or [NO] to cancel it.

4.6.7 Moving the Memory

Follow the step below to move the memory location:

1. Use ▲ ▼ to move the highlight to the memory to be moved and press Function Key [MOVE UP] or [MOVE DOWN].

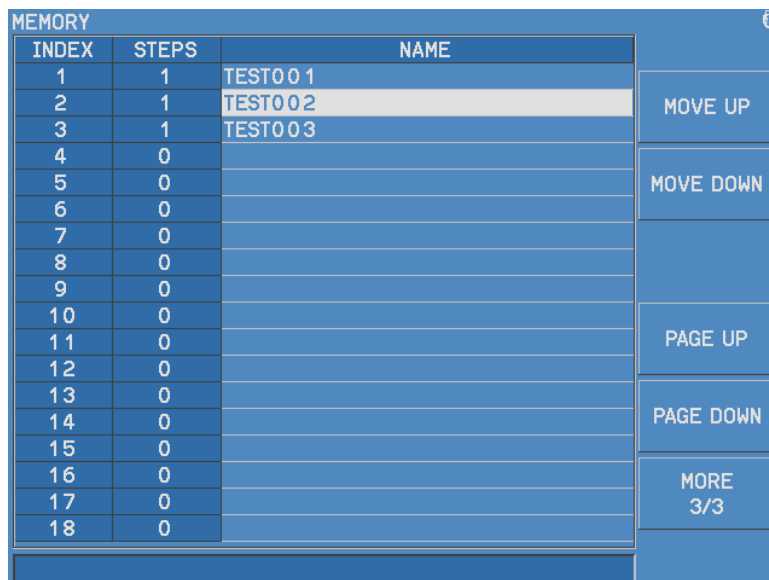

MEMORY		
INDEX	STEPS	NAME
1	1	TEST002
2	1	TEST001
3	1	TEST003
4	0	
5	0	
6	0	
7	0	
8	0	
9	0	
10	0	
11	0	
12	0	
13	0	
14	0	
15	0	
16	0	
17	0	
18	0	

4.7 Setting PROGRAM

4.7.1 Setting Program Procedure

1. Press Function key [PROGRAM] in power on screen to go to PROGRAM setting screen as below:

PROGRAM				
STEP	1/1		MODE	AC
OUTPUT	1.000kV			
LIMIT	HIGH	LOW	ARC	REAL
	3.00mA	OFF	OFF	OFF
TIME	RAMP	TEST	FALL	
	1.0s	3.0s	OFF	
HFCC	Cs	OPEN	SHORT	
	OFF	50%	300%	
INTERNAL	○○○○○○○○○○○○○○			
SCANNER1	○○○○○○○○○○○○○○○○○○○○			
SCANNER2	○○○○○○○○○○○○○○○○○○○○			
1-60 (TOTAL)				

2. Press **▲** **▼** **◀** **▶** to move the highlight to the steps to be set. Use numeric/character keys or mapped function key to modify the parameter and press **ENTER** to confirm the modification.
3. Use Function key [+][-] to move the cursor to previous or next test step.
4. Use Function key [NEW STEP] to add a new test step. The range is 1~100.
5. Use Function key [NEW SUB] to add a sub step. When the main step judges the DUT as Pass, the sub step will skip and it will run when the main step judges the DUT as fail to get a more complete test result.

6. Use Function key [INSERT STEP] to insert a new test step.
7. Use Function key [MORE 1/2] to switch to the Function keys on next page as shown below.



8. Use Function key [COPY] to copy a test step.
9. Use Function key [PASTE] to paste up a test step.
10. Use Function key [INSERT] to insert a copied test step.
11. Use Function key [CUT] to cut a test step.
12. Use Function key [DELETE] to delete a test step.
13. Press Function key [NEXT 2/2] to return to previous page and continue to set other program.

4.7.2 Selecting Test Mode

1. When in PROGRAM screen, press  to move the highlight to the following position.



2. Use Function key [AC], [DC], [IR], [DCR], [IWT] or [MORE 1/3] to select a test mode. There are AC / DC / IR / DCR / IWT / Δ / Y DCR / IWT COMPARE / HSCC / OSC / PA / Lx / Lx BALANCE / EXTERIOR CONNECT test modes available for selection. Different test mode has different programs for setting.

4.7.3 Description of Parameters

Following explains the parameters in each test mode.

Withstand Voltage AC (AC) Test Mode

The screenshot shows the 'PROGRAM' screen for 'AC' test mode. The 'STEP' is 1/1 and 'MODE' is AC. The 'OUTPUT' is set to 0.000kV. The 'LIMIT' section includes HIGH (3.00mA), LOW (OFF), ARC (OFF), and REAL (OFF). The 'TIME' section includes RAMP (OFF), TEST (3.0s), and FALL (OFF). The 'HFCC' section includes Cs (OFF), OPEN (50%), and SHORT (300%). There are also sections for 'INTERNAL', 'SCANNER1', and 'SCANNER2' with circular indicators. A 'SELECT MODE' button is at the bottom left. On the right side, there is a vertical menu with buttons for AC, DC, IR, DCR, IWT, and MORE 1/3.

- OUTPUT** : It sets the voltage required for withstand voltage test. The range is 0.05kV to 5kV.
- HIGH** : It sets the high limit of leakage current. The range is 0.001mA to 120mA. (When the voltage setting is larger than 4kV, the range is 0.001mA to 100mA.)
- LOW** : It sets the low limit of leakage current. The range is 0.001mA to the leakage current high limit or OFF.
- ARC** : It sets the high limit of arc. The range is 1mA to 20mA or OFF.
- REAL** : It sets the high limit of real leakage current. The range is 0.001mA to the leakage current high limit or OFF.
- RAMP** : It sets the time required for ramping to the set voltage. The range is 0.1 to 999 seconds or OFF.
- TEST** : It sets the time required for test. The range is 0.3 to 999 seconds or continuous test.
- FALL** : It sets the time required for falling to low voltage from set. The range is 0.1 to 999 seconds or OFF.
- Cs** : It sets the standard capacitance for High Frequency Contact Check (HFCC). OFF means no check.
- OPEN** : It sets the test result of HFCC = open condition (compare test readings with the read standard capacitance.)
- SHORT** : It sets the test result of HFCC = short condition (compare test readings with the read standard capacitance.)
- INTERNAL** : It sets the status of EST Analyzer test output. Available settings are NONE/HIGH/LOW.
- SCANNER1**: It sets the output status of scanner test fixture 1. Available settings are NONE/HIGH/LOW.
- SCANNER2**: It sets the output status of scanner test fixture 2. Available settings are NONE/HIGH/LOW.

Withstand Voltage DC (DC) Test Mode

- OUTPUT** : It sets the voltage required for withstand voltage test. The range is 0.05kV to 6kV.
- HIGH** : It sets the high limit of leakage current. The range is 0.0001mA to 20mA.
- LOW** : It sets the low limit of leakage current. The range is 0.0001mA to the leakage current high limit or OFF.
- ARC** : It sets the high limit of arc. The range is 1mA to 10mA or OFF.
- ARC RAMP**: It sets the high limit of arc for RAMP TIME. The range is 1mA to 10mA or DEFAULT. When set to DEFAULT, the ARC RAMP setting is the same as ARC setting.
- RAMP** : It sets the time required for ramping to the set voltage. The range is 0.1 to 999 seconds or OFF.
- DWELL** : It sets the time required for DWELL. The range is 0.1 to 999 seconds or OFF. (It does not judge the high and low limit of leakage current during DWELL TIME but only when the set range is within the high limit.)
- TEST** : It sets the time required for test. The range is 0.3 to 999 seconds or continuity.
- FALL** : It sets the time required for falling to low voltage from set. The range is 0.1 to 999 seconds or OFF.
- Cs** : It sets the standard capacitance for High Frequency Contact Check (HFCC). OFF means no check.
- OPEN** : It sets the test result of HFCC = open condition (compare test readings with the read standard capacitance.)
- SHORT** : It sets the test result of HFCC = short condition (compare test readings with the read standard capacitance.)
- INTERNAL** : It sets the status of EST Analyzer test output. Available settings are NONE/HIGH/LOW.
- SCANNER1**: It sets the output status of scanner test fixture 1. Available settings are NONE/HIGH/LOW.
- SCANNER2**: It sets the output status of scanner test fixture 2. Available settings are NONE/HIGH/LOW.

Insulation Resistance (IR) Test Mode

PROGRAM

STEP **1/1** MODE **IR**

OUTPUT **0.000kV**

LIMIT LOW **1.0MΩ** HIGH **OFF**

TIME RAMP **OFF** DWELL **OFF** TEST **3.0s** FALL **OFF**

RANGE **AUTO**

INTERNAL ○○○○○○○○○○○○

SCANNER1 ○○○○○○○○○○○○

SCANNER2 ○○○○○○○○○○○○

SELECT MODE

AC

DC

IR

DCR

IWT

MORE 1/3

- OUTPUT** : It sets the required voltage for insulation resistance test. The range is 0.05kV to 5kV.
- LOW** : It sets the low limit for insulation resistance. The range is 0.1MΩ to 50GΩ.
- HIGH** : It sets the high limit for insulation resistance. The range is the insulation resistance low limit to 50GΩ or OFF
- RAMP** : It sets the time required for ramping to the set voltage. The range is 0.1 to 999 seconds or OFF.
- DWELL** : It sets the time required for DWELL. The range is 0.1 to 999 seconds or OFF. (It does not judge the high and low limit of leakage current during DWELL TIME but only when the set range is within the high limit.)
- TEST** : It sets the time required for test. The range is 0.3 to 999 seconds or continuity.
- FALL** : It sets the time required for falling to low voltage from set. The range is 0.1 to 999 seconds or OFF.
- RANGE** : It sets the current test range for insulation resistance, AUTO means switching the range automatically. When the DUT is having Corona, it is possible that the ranges are skipping in between, please use HOLD RANGE to do the test.

Notice

To select an appropriate IR current range, please calculate the current by test voltage and DUT's insulation impedance, and then select the proper current range.

- INTERNAL** : It sets the status of EST Analyzer test output. Available settings are NONE/HIGH/LOW.
- SCANNER1**: It sets the output status of scanner test fixture 1. Available settings are NONE/HIGH/LOW.
- SCANNER2**: It sets the output status of scanner test fixture 2. Available settings are NONE/HIGH/LOW.

DC Resistance (DCR) Test Mode

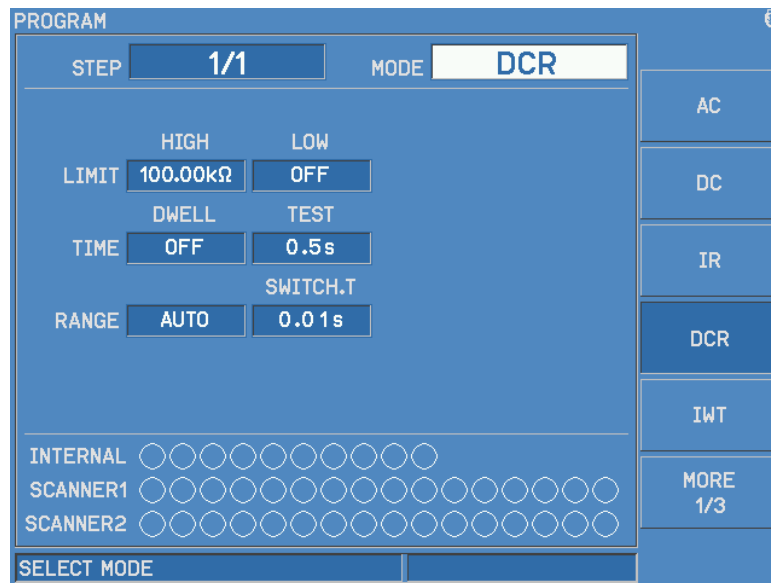

- HIGH** : It sets the high limit for DC resistance. The range is 0.1mΩ to 2MΩ.
- LOW** : It sets the low limit for DC resistance. The range is 0.1mΩ to the DC resistance high limit or OFF
- DWELL** : It sets the time required for DWELL. The range is 0.1 to 999 seconds or OFF. (It does not judge the high and low limit of leakage current during DWELL TIME but only when the set range is within the high limit.)
- TEST** : It sets the action for DCR TIME.
 (1) Set to KEY: Setting to CONTINUE indicates the DCR test will continue until the **START** key on the panel is pressed or the /EXT_START signal on HANDLER card is retrigged.
 (2) Set the test time: Use numeric keys to set the test time required by DCR. The range is 0.1 to 999 seconds.
- RANGE** : It sets the test range for DC resistance, AUTO means switching range automatically.
- SWITCH T** : It sets the time for switching range or starting. The range is 0.01 to 0.2 second.
- INTERNAL** : It sets the status of EST Analyzer test output. Available settings are NONE/HIGH/LOW.
- SCANNER1**: It sets the output status of scanner test fixture 1. Available settings are NONE/HIGH/LOW.
- SCANNER2**: It sets the output status of scanner test fixture 2. Available settings are NONE/HIGH/LOW.

Please see section 4.7.4 for the temperature measurement function in DCR mode.

Impulse Winding Test (IWT) Mode

PROGRAM				
STEP	1/1		MODE IWT	
OUTPUT	VOLTAGE	WIDTH	PULSE	
	0.00kV	6	1.0	
AREA	BEGIN	END	LIMIT+	LIMIT-
	1	512	OFF	OFF
DIF-AREA	1	512	OFF	
FLUTTER	1	512	OFF	
LAPLAC	1	512	OFF	
INTERNAL	○○○○○○○○○○○○○○			
SCANNER1	○○○○○○○○○○○○○○○○○○○○			
SCANNER2	○○○○○○○○○○○○○○○○○○○○			
SELECT MODE				

PROGRAM		
STEP	1/1	
MODE	IWT	
ΔPk%	LIMIT+	LIMIT-
	OFF	OFF
ΔR.AREA	OFF	OFF
ΔFREQ	OFF	OFF
INTERNAL	○○○○○○○○○○○○○○	
SCANNER1	○○○○○○○○○○○○○○○○○○○○	
SCANNER2	○○○○○○○○○○○○○○○○○○○○	
SELECT MODE		

- OUTPUT : It sets the required impulse voltage for testing. The range is 0.1kV to 6kV.
- WIDTH : It sets the waveform sampling rate. The range is 1~11 where 1 means high sampling rate and 11 means low sampling rate.
- PULSE : It sets pulse number for testing. The range is 1.0 to 32.9 where the number before the decimal point is the number of judged pulses, and the number after the decimal point is the number of not judged pulses.
- AREA : It sets the boundary value for area comparison.
- (1) BEGIN: It sets the start for area comparison. The range is 1 to 512.
 - (2) END: It sets the end for area comparison. The range is 1 to 512.
 - (3) LIMIT+: It sets the high limit percentage for area comparison. The range is 0.1% to 99.9% or OFF.
 - (4) LIMIT-: It sets the low limit percentage for area comparison. The range is 0.1% to 99.9% or OFF.
- DIF-AREA : It sets the boundary for differential area comparison.
- (1) BEGIN: It sets the start for differential area comparison. The range is 1 to

- 512.
- (2) END: It sets the end for differential area comparison. The range is 1 to 512.
- (3) LIMIT+: It sets high limit percentage for differential area comparison. The range is 0.1% to 99.9% or OFF.
- FLUTTER : It sets the limit of flutter.
- (1) BEGIN: It sets the start of flutter. The range is 1 to 512.
- (2) END: It sets the cut-off point of flutter. The range is 1 to 512.
- (3) LIMIT+: It sets the high limit of flutter. The range is 1 to 9999 or OFF.
- LAPLAC : It sets the limit of Laplacian.
- (1) BEGIN: It sets the start of Laplacian. The range is 1 to 512.
- (2) END: It sets the cut-off point of Laplacian. The range is 1 to 512.
- (3) LIMIT+: It sets the high limit of Laplacian. The range is 1 to 9999 or OFF.
- Δ Pk% : It sets the judgment limit of delta peak ratio.
- (1) LIMIT+ : It sets the high limit percentage for delta peak ratio. The range is 0.1% to 99.9% or OFF.
- (2) LIMIT- : It sets the low limit percentage for delta peak ratio. The range is 0.1% to 99.9% or OFF.
- Δ R.AREA : It sets the judgment limit for resonance area comparison
- (1) LIMIT+ : It sets the high limit percentage for delta peak ratio. The range is 0.1% to 99.9% or OFF.
- (2) LIMIT- : It sets the low limit percentage for delta peak ratio. The range is 0.1% to 99.9% or OFF.
- Δ FREQ : It sets the judgment limit for delta frequency.
- (1) LIMIT+ : It sets the high limit percentage for delta peak ratio. The range is 0.1% to 99.9% or OFF.
- (2) LIMIT- : It sets the low limit percentage for delta peak ratio. The range is 0.1% to 99.9% or OFF.
- INTERNAL : It sets the status of EST Analyzer test output. Available settings are NONE/HIGH/LOW.
- SCANNER1: It sets the output status of scanner test fixture 1. Available settings are NONE/HIGH/LOW.
- SCANNER2: It sets the output status of scanner test fixture 2. Available settings are NONE/HIGH/LOW.

Impulse Winding Test SAMPLE GET

When setting the program for IWT MODE, press Function key [SAMPLE] to go to IWT MODE SAMPLE GET function setting as shown below.

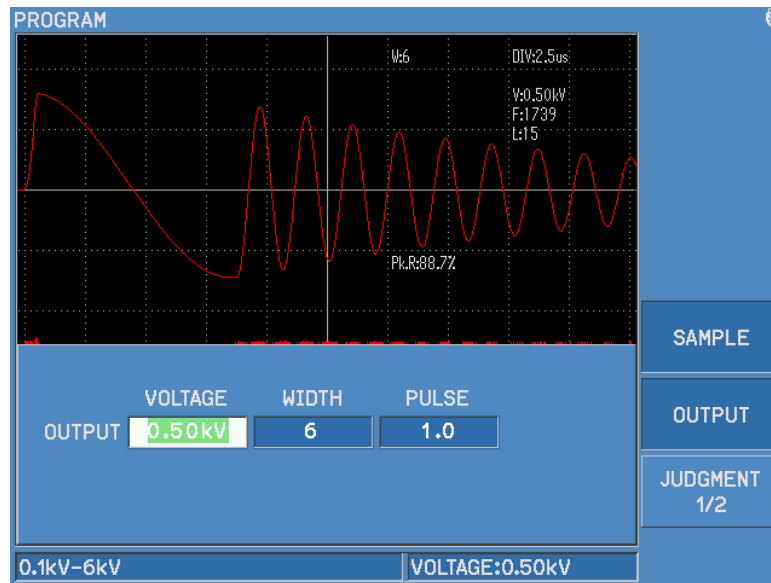

In the screen it can set the impulse [VOLTAGE], sampling rate [WIDTH] and [PULSE] number in IWT MDOE. The settings are the same as in PROGRAM screen. When the settings are done, connect the output to SAMPLE and press **START** to get the SAMPLE waveform as shown in red in the above figure.

Press Function key [JUDGMENT] to show the screen below.

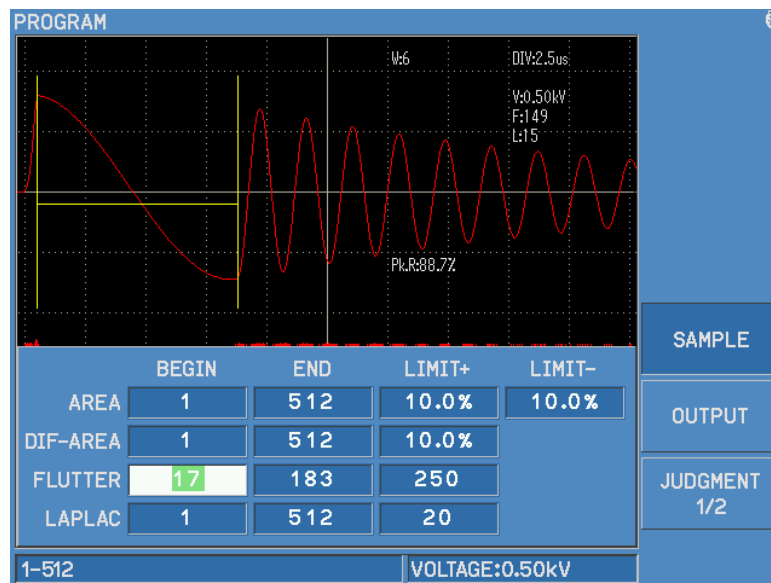

This screen sets the conditions of AREA, DIF-AREA, FLUTTER and LAPLAC as the judgment range for defect products in IWT MODE. [BEGIN] sets the start and [END] sets the cut-off point for judgment. When the cursor moves to [BEGIN] or [END], besides using the numeric keys to input the judgment range, it can use **ENTER** as the yellow line shown in the figure above.

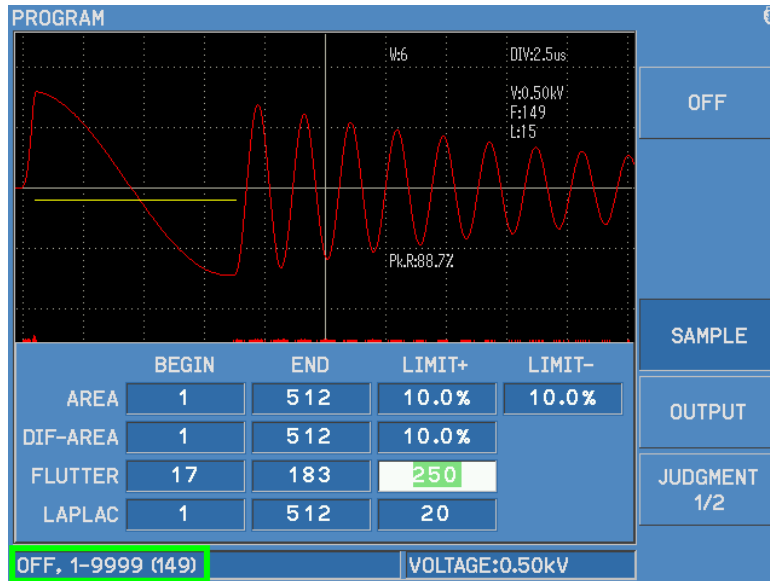

When the cursor moves to FLUTTER and LIMIT+ of LAPLAC, if the SAMPLE waveform has got, the lower left corner message line for input range will show the SAMPLE FLUTTER and LAPLAC reading in (xxx). This reading can be used as a reference for inputting the setting of LIMIT+ as the green box shown in the figure above.

Notice

1. The SAMPLE waveform of impulse winding testing will save to the memory along with the PROGRAM in IWT MODE.
2. Please Chapter 6 for detail description of impulse winding test mode.
3. Changing the VOLTAGE, WIDTH, CHANNEL, and IWT INTRETVAL settings will clear the SAMPLE waveform data. Please redo SAMPLE GET before testing.
4. $\Delta Pk\%$, $\Delta R.AREA$, and $\Delta FREQ$ judgment must have enough resonance period for calculation. If not enough, it will display SAMPLE FAIL (NOT ENOUGH CYCLES).

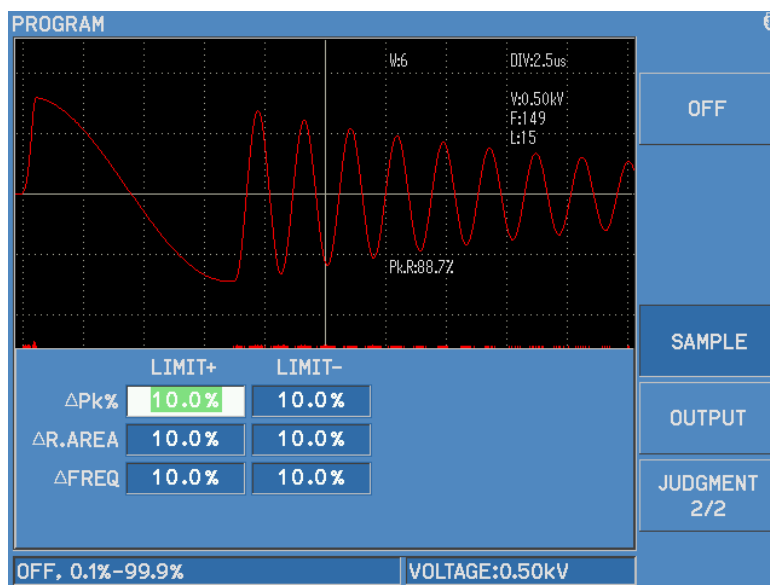

Δ /Y DC Resistance (Δ /Y DCR) Test Mode

The screenshot shows the PROGRAM screen for the Δ /Y DCR test mode. The screen is divided into several sections:

- STEP:** 1/1
- MODE:** Δ /Y DCR
- TYPE:** Δ
- Rab, Rbc, Rca, BALANCE:**
 - Rab: HIGH 100.00k Ω , LOW OFF
 - Rbc: HIGH 100.00k Ω , LOW OFF
 - Rca: HIGH 100.00k Ω , LOW OFF
 - BALANCE: OFF
- TEST (x3):** TIME 0.5s
- RANGE:** AUTO
- SWITCH.T:** 0.01s
- INTERNAL:** 10 empty circles
- SCANNER1:** 10 empty circles
- SCANNER2:** 10 empty circles
- SELECT MODE:** (empty)
- Right-side buttons:** Δ /Y DCR, IWT COMPARE, HSCC, OSC, PA, MORE 2/3

TYPE : It sets the Δ /Y DC resistance measurement mode to Δ or Y mode.

(1) Δ mode

Rab: It sets the Rab DC resistance judgment condition in Δ mode.

HIGH: It sets the high limit of Rab DC resistance. The range is 0.1m Ω to 2M Ω .

LOW: It sets the low limit of Rab DC resistance. The range is 0.1m Ω to the Rab DC resistance high limit or OFF.

Rbc: It sets the Rbc DC resistance judgment condition in Δ mode.

HIGH: It sets the high limit of Rbc DC resistance. The range is 0.1m Ω to 2M Ω .

LOW: It sets the low limit of Rbc DC resistance. The range is 0.1m Ω to the Rbc DC resistance high limit or OFF.

Rca: It sets the Rca DC resistance judgment condition in Δ mode.

HIGH: It sets the high limit of Rca DC resistance. The range is 0.1m Ω to 2M Ω .

LOW: It sets the low limit of Rca DC resistance. The range is 0.1m Ω to the Rca DC resistance high limit or OFF.

(2) Y mode

R1: It sets the DC resistance judgment condition of R1 in Y mode.

HIGH: It sets the high limit of R1 DC resistance. The range is 0.1m Ω to 2M Ω .

LOW: It sets the low limit of R1 DC resistance. The range is 0.1m Ω to the R1 DC resistance high limit or OFF.

R2: It sets the DC resistance judgment condition of R2 in Y mode.

HIGH: It sets the high limit of R2 DC resistance. The range is 0.1m Ω to 2M Ω .

LOW: It sets the low limit of R2 DC resistance. The range is 0.1m Ω to the R2 DC resistance high limit or OFF.

R3: It sets the DC resistance judgment condition of R3 in Y mode.

HIGH: It sets the high limit of R3 DC resistance. The range is 0.1m Ω to 2M Ω .

LOW: It sets the low limit of R3 DC resistance. The range is 0.1m Ω to the R3 DC resistance high limit or OFF.

BALANCE : It sets the Δ /Y DCR BALANCE judgment condition. When the difference of

DCR maximum and minimum is larger than the setting of Δ/Y DCR Balance, it is judged as Balance Fail. When the difference of DCR maximum and minimum is smaller than Δ/Y DCR Balance, it is judged as Pass.

- TEST : It sets the Δ/Y DCR test time ranged from 0.5 to 1 second. Since Δ/Y DCR needs to test 3 points to get actual resistance, thus the test time is the set time multiplies 3 times.
- RANGE : It sets the resistance test range for DC resistance. AUTO means to switch the range automatically.
- SWITCH T : It sets the time for switching range or starting. The range is 0.01 to 0.2 second.
- INTERNAL : It sets the output terminal status of this EST Analyzer. It can set Δ/Y DCR to measure point A or B or C. If more than 2 scanning test points are set to the same measurement points (such as setting 2 measurement A points), it means these two measurement points are parallel.
- SCANNER1: It sets the output terminal status of external Scanner 1. It can set Δ/Y DCR to measure point A or B or C. If more than 2 scanning test points are set to the same measurement points (such as setting 2 measurement A points), it means these two measurement points are parallel.
- SCANNER2: It sets the output terminal status of external Scanner 2. It can set Δ/Y DCR to measure point A or B or C. If more than 2 scanning test points are set to the same measurement points (such as setting 2 measurement A points), it means these two measurement points are parallel.

The measurement circuit diagrams of Δ and Y modes are shown below. The status of output terminals A B C are set to the A or B or C in the Δ or Y mode measurement circuit diagram below.

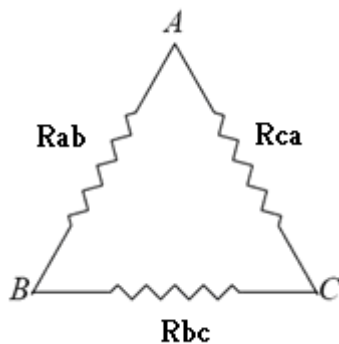

Δ Mode Measurement Diagram

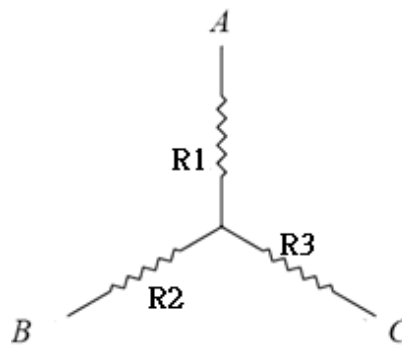

Y Mode Measurement Diagram

Impulse Winding Test COMPARE (IWT CMP) Mode

- OUTPUT** : It sets the impulse voltage required for testing. The range is 0.1kV to 6kV.
- WIDTH** : It sets the waveform sampling rate. The range is 1~11 in which 1 is high sampling speed and 11 is low sampling speed. The smaller the number, the smaller time range displays on the screen and the larger the number, the larger time range displays on the screen.
- PULSE** : It sets the pulse number for testing. The range is 1.0 to 1.9 where the number before the decimal point is the number of judged pulses, and the number after the decimal point is the number of not judged pulses.
- AREA** : It sets the area comparison limit.
- (1) **BEGIN**: It sets the start for area comparison. The range is 1 to 512.
 - (2) **END**: It sets the end for area comparison. The range is 1 to 512.
 - (3) **LIMIT+**: It sets the area comparison percentage for high limit. The range is 0.1% to 99.9% or OFF.
 - (4) **LIMIT-**: It sets the area comparison percentage for low limit. The range is 0.1% to 99.9% or OFF.
- DIF-AREA** : It sets the comparison of area difference limit
- (1) **BEGIN**: It sets the start for area difference comparison. The range is 1 to 512.
 - (2) **END**: It sets the end for area difference comparison. The range is 1 to 512.
 - (3) **LIMIT+**: It sets the comparison percentage for area difference comparison. The range is 0.1% to 99.9% or OFF.
- FLUTTER** : It sets the flutter limit.
- (1) **BEGIN**: It sets the start of flutter. The range is 1 to 512.
 - (2) **END**: It sets the end of flutter. The range is 1 to 512.
 - (3) **LIMIT+**: It sets the limit of flutter. 0 is OFF. The range is 1 to 9999 or OFF.
- LAPLAC** : It sets the LAPLACIAN limit.
- (1) **BEGIN**: It sets the start of LAPLACIAN. The range is 1 to 512.
 - (2) **END**: It sets the end of LAPLACIAN. The range is 1 to 512.
 - (3) **LIMIT+**: It sets the limit of LAPLACIAN. 0 is OFF. The range is 1 to 999 or OFF.
- HIGH** : It sets the HIGH scan channel for IWT Compare.
- LOW** : It sets the s LOW can channel for IWT Compare.

Notice

- The numbers inputted for scan channels are:
- 1-10 indicate CH1~CH10 for EST Analyzer output (INTERNAL).
- 101-116 indicate CH1~CH16 of the SCANBOX (SCANNER1).
- 201-216 indicate CH1~CH16 of the SCANBOX (SCANNER2).
- Function key [OFF] can cancel the set channel.

IWT COMPARE SAMPLE GET

When setting the parameters for IWT COMPARE, press Function key [SAMPLE] to enter into the IWT COMPARE SAMPLE GET functions as the figure shown below.

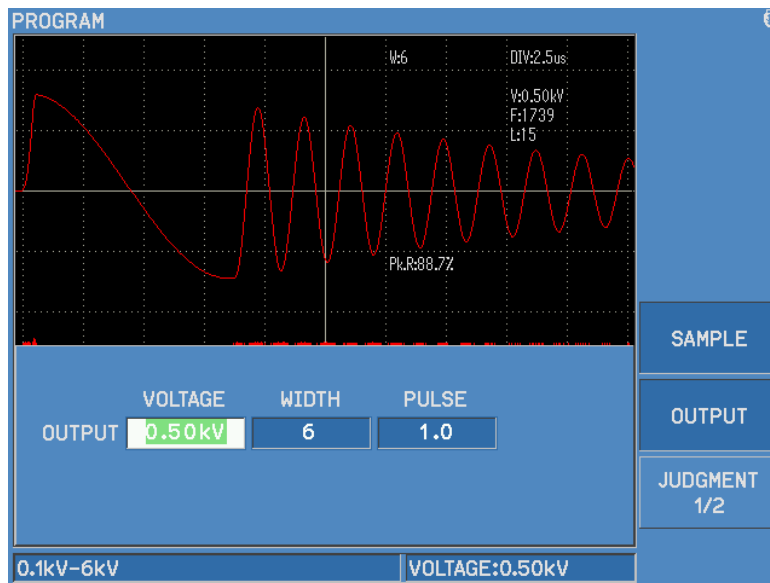

This screen sets the IWT COMPARE impulse [VOLTAGE], sampling rate [WIDTH] and no. of [PULSE]. The functions are the same as the PROGRAM setting screen. When the settings are done and the winding 1 output is connected to SAMPLE, press **START** to get the SAMPLE waveform as the red waveform shown in the above figure.

Press Function key [JUDGMENT] and the screen shown as below.

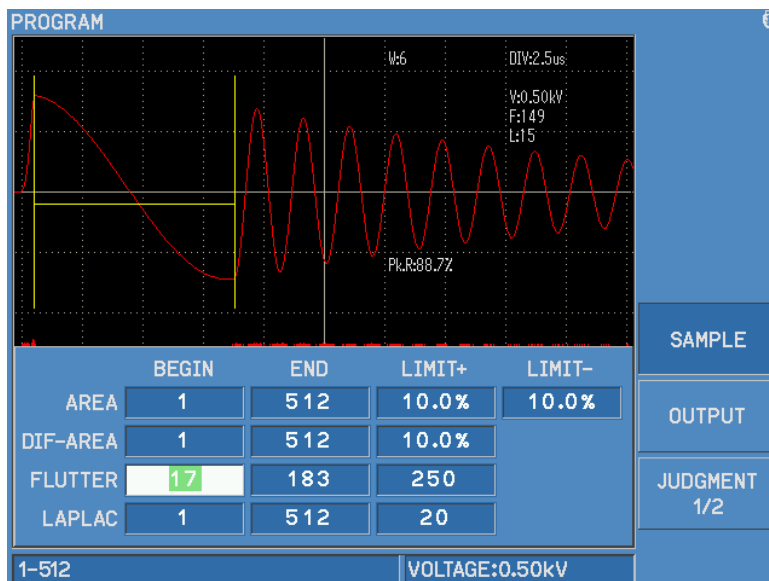

This screen sets the IWT COMPARE judgment ranges under the conditions of AREA, DIF-AREA, FLUTTER and LAPLAC. [BEGIN] is the start for judgment while [END] is the end. When the cursor moves to [BEGIN] or [END], beside using the numeric keys to enter the range, it can press **ENTER** and use **◀ ▶** to set the range as the yellow line shown in the above figure.

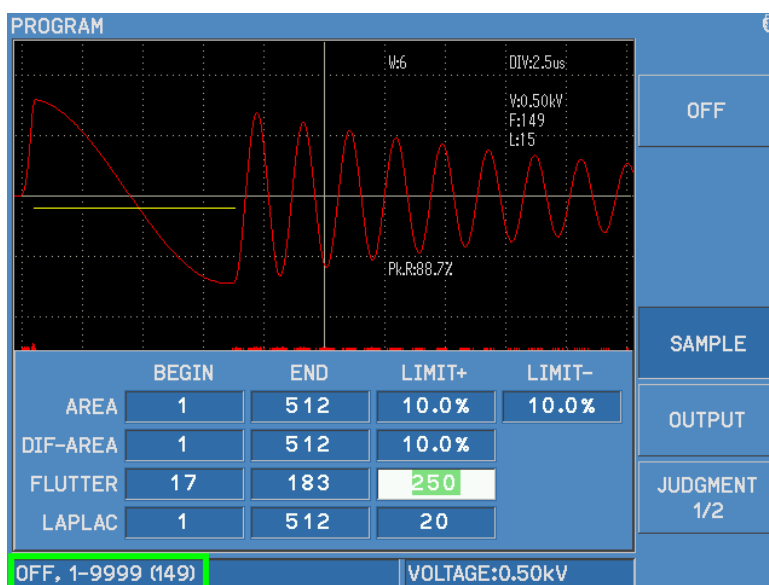

When the cursor moves to the LIMIT+ of FLUTTER and LAPLAC, if the SAMPLE waveform has got, the input range on message line at the lower left corner will show the reading of SAMPLE FLUTTER and LAPLAC in (xxx) which can be used to set the LIMIT+ as the green box and highlight shown above.

Notice

1. The IWT COMPARE SAMPLE waveform will save to the memory along with the data of IWT COMPARE PROGRAM.
2. Refer to Chapter 6 for the detail description of IWT COMPARE.
3. Changing the VOLTAGE, WIDTH, and IWT INTERVAL settings will clear the SAMPLE waveform data. Please redo SAMPLE GET before

- 4. Winding 1 to 6 can be set as desired and sampling uses the first group channel to set the output. It has to be more than two groups for sampling; otherwise, it will show CHANNEL INVALID.

High Speed Contact Check (HSCC) Mode

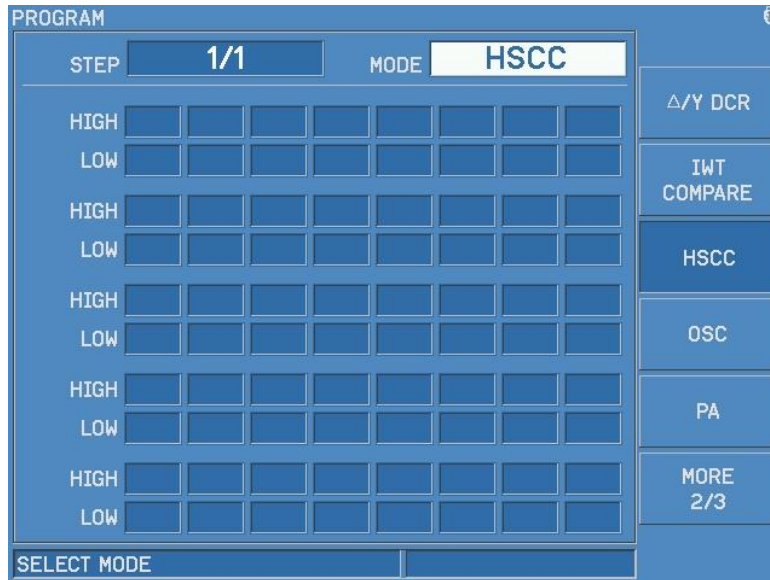

HIGH : It sets the HIGH end scan channel for High Speed Contact Check.
 LOW : It sets the LOW end scan channel for High Speed Contact Check.

Notice

- The numbers inputted for scan channels are:
- 1-10 indicate CH1~CH10 for EST Analyzer output (INTERNAL).
- 101-116 indicate CH1~CH16 of the SCANBOX (SCANNER1).
- 201-216 indicate CH1~CH16 of the SCANBOX (SCANNER2).
- Function key [OFF] can cancel the set channel.

As the figure shown below, the test is only PASS when the CH1 is opened with CH2, CH3 is opened with CH4 and CH5 is opened with CH6; otherwise it will be OPEN FAIL.

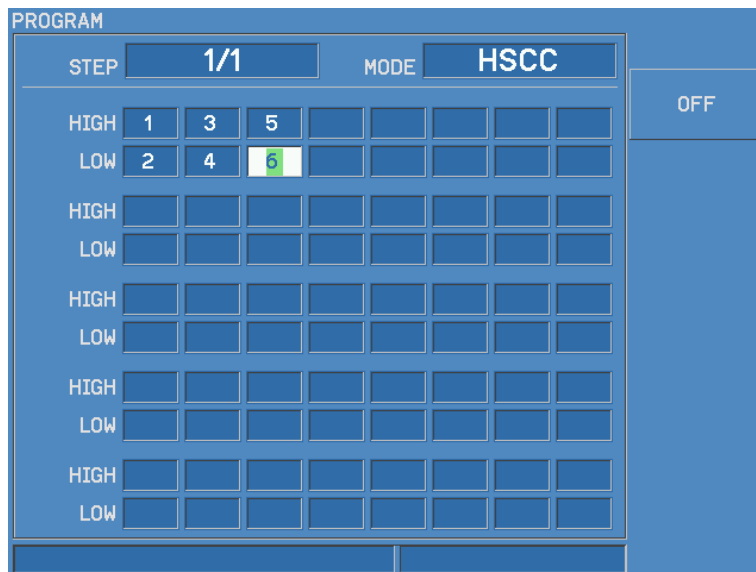

Open/Short Check (OSC) Test Mode



- Cs** : It sets the standard capacitance for Open/Short Check mode. If the standard capacitance is known already, enter it directly or use SAMPLE TEST to get a sample. See detail description of sampling in section 4.8.4.
- OPEN** : It sets the OPEN condition for test result judgment. (Compare the test readings with the read standard capacitance [Cs].)
- SHORT** : It sets the SHORT condition for test result judgment. (Compare the test readings with the read standard capacitance [Cs].)
- INTERNAL** : It sets the status of EST Analyzer test output. Available settings are NONE/HIGH/LOW.
- SCANNER1**: It sets the output status of scanner test fixture 1. Available settings are NONE/HIGH/LOW.
- SCANNER2**: It sets the output status of scanner test fixture 2. Available settings are NONE/HIGH/LOW.

Pause (PA) Mode



- MESSAGE : It sets the message to show on the screen in pause mode for maximum 15 characters.
- TIME : It sets the behavior of PAUSE MODE.
- (1) Set to KEY: Press the Function key [KEY] to set and the pause mode ends until the **START** key on panel is pressed or START signal from HANDLER card (OPTION) is triggered.
 - (2) Set to 0.1~9999 secs: The pause mode ends when it reaches the time set for pause.

Inductance (Lx) Mode

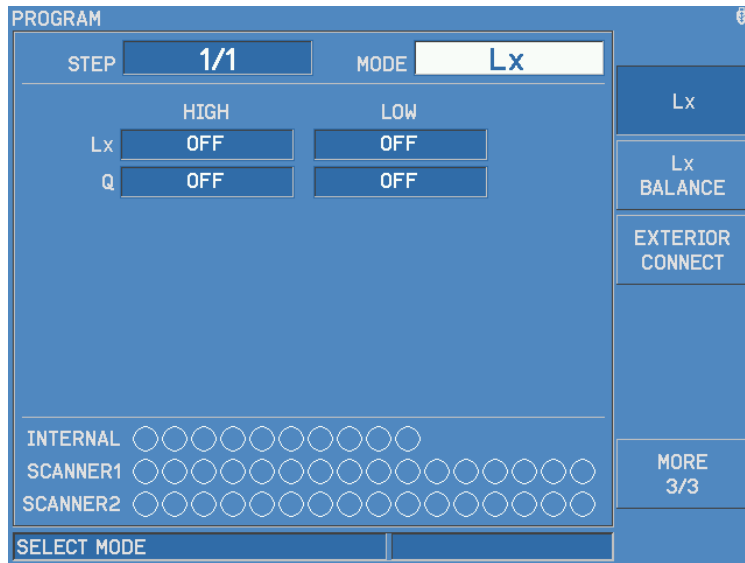

- Lx : It sets the inductance HIGH/Low limit. The High limit is -99.999MH~99.999MH or OFF, while the Low limit is -99.999MH~99.999MH or OFF.
- Q : It sets the quality faction high/low limit. The maximum range (HIGH) is -99999~99999 or OFF, while the minimum range (LOW) is -99999~99999 or OFF.
- INTERNAL : It sets the status of EST Analyzer test output. Available settings are NONE/HIGH/LOW.
- SCANNER1: It sets the output status of scanner test fixture 1. Available settings are NONE/HIGH/LOW.
- SCANNER2: It sets the output status of scanner test fixture 2. Available settings are NONE/HIGH/LOW.

Notice

When setting the HIGH/Low limits for Lx and Q, if the High limit is smaller than the Low limit, both of them are the High limits; and if the Low limit is bigger than the High limit, then both of them are Low limits.

Inductance Balance (Lx BALANCE) Mode

The screenshot shows a control panel for the 'Lx BALANCE' mode. At the top, it displays 'PROGRAM' and 'STEP 1/1'. The 'MODE' is set to 'Lx BL'. Below this, 'TYPE' is set to 'PERCENT' and 'LIMIT' is 'OFF'. The main area contains three rows of 'HIGH' and 'LOW' scan channel selection buttons. On the right side, there are buttons for 'Lx', 'Lx BALANCE', 'EXTERIOR CONNECT', and 'MORE 3/3'. At the bottom, there is a 'SELECT MODE' button.

TYPE : It sets the error display of inductance and inductance average in percentage or absolute value:

1. Percentage: $\frac{|\text{Inductance} - \text{Inductance Average}|}{\text{Inductance average}}$
2. Absolute value: $|\text{Inductance} - \text{Inductance Average}|$

LIMIT : It sets the high limit of error percentage or absolute value.

HIGH : It sets the HIGH scan channel for high speed contact check.

LOW : It sets the LOW scan channel for high speed contact check.

Notice

- The numbers inputted for scan channels are:
- 1-10 indicate CH1~CH10 for EST Analyzer output (INTERNAL).
- 101-116 indicate CH1~CH16 of the SCANBOX (SCANNER1).
- 201-216 indicate CH1~CH16 of the SCANBOX (SCANNER2).
- Function key [OFF] can cancel the set channel.

EXTERIOR CONNECT (EXT. CONN) Mode

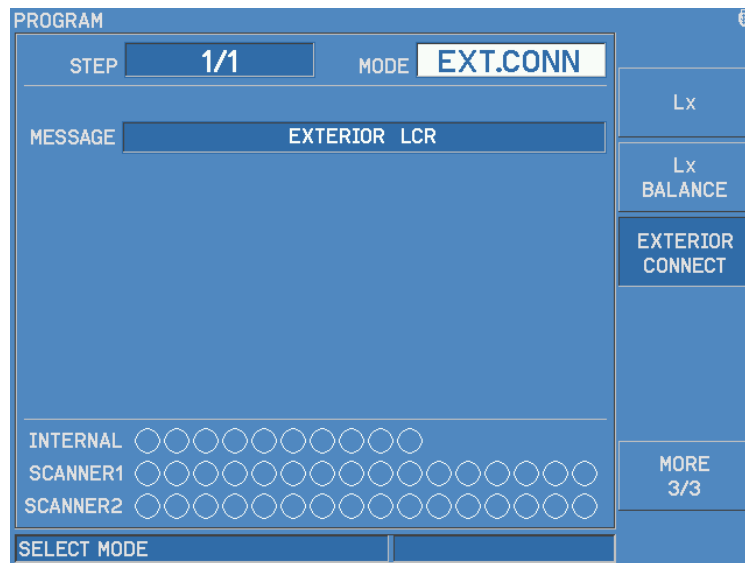

- MESSAGE : It sets the message to show on the screen for maximum 15 characters when connected exteriorly.
- INTERNAL : It sets the status of EST Analyzer test output. Available settings are NONE/HIGH/LOW.
- SCANNER1: It sets the output status of scanner test fixture 1. Available settings are NONE/HIGH/LOW.
- SCANNER2: It sets the output status of scanner test fixture 2. Available settings are NONE/HIGH/LOW.

4.7.4 Temperature Measurement

The temperature measurement function is available for 19036 when the temperature interface and temperature probe are purchased for use. It can measure the DUT and environment temperature. The temperature measurement function of 19036 needs to work with appropriate interface and probe purchased for application.

4.7.4.1 Temperature Measurement Interface

The temperature measurement interface is installed on the 19036 rear panel and uses the hole of TC SENSOR as measurement input in the figure below:

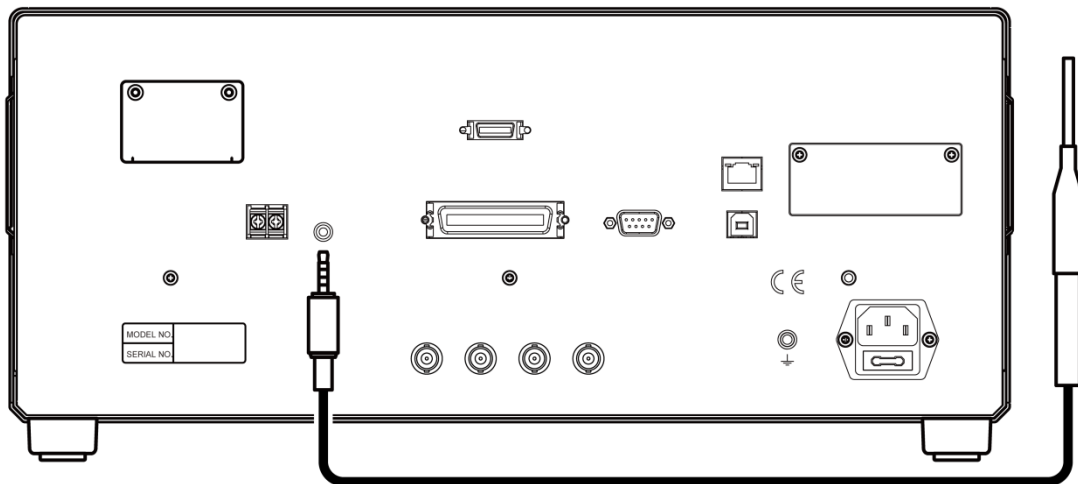

Figure 4-3

4.7.4.2 Temperature Probe

The standard temperature probe of 19036 is a PT100 Model platinum temperature sensor with a 1.5 meters cable. The probe head can measure the temperature from -50°C \sim 300°C . When using insert its plug to the TC SENSOR hole on the 19036 rear panel. The following figure shows the temperature probe.

A165015 Temperature Probe

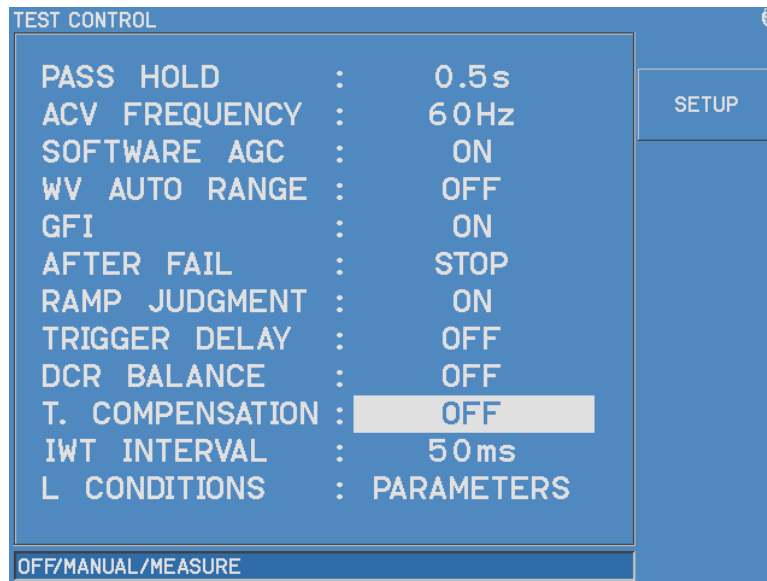

Figure 4-4

4.7.4.3 Setting Temperature Compensation

Procedure:

1. When the 19036 is powered on, press **SYSTEM** in any screen and move the highlight to TEST CONTROL, press **ENTER** to enter into TEST CONTROL setting screen. Next move the highlight to T. COMPENSATION and press Function key [SETUP] to enter into temperature compensation setting as shown below.



2. The following screen shows the temperature compensation settings.

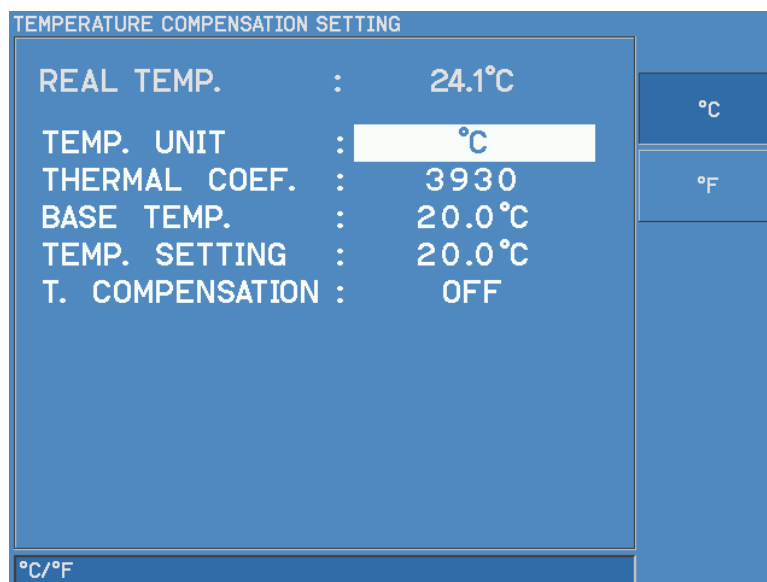

3. The table below lists the setting items of temperature compensation and their description:

Items	Range	Default	Description
REAL TEMP.			It shows the temperature at present. It shows ----- if the hardware does not exist.
TEMP. UNIT	°C /°F	°C	It is the temperature unit.
THERMAL COEFF.	0~9999ppm	3930ppm	It is the temperature coefficient.
BASE TEMP.	-10°C ~99.9°C (14°F ~211.8°F)	20°C (68°F)	It is standard site temperature.
TEMP. SETTING	-10°C ~99.9°C (14°F ~211.8°F)	20°C (68°F)	It is the environment temperature. Use this parameter when set to MANUAL.
T. COMPENSATION	OFF/MANUAL/ MEASURE	OFF	It turns on the temperature compensation function. OFF means not

			to execute temperature compensation, MANUAL means to use temperature set by TEMP. SETTING for compensation, while MEASURE means to use the measured temperature for compensation.
--	--	--	---

4. There are three modes available for selection when in the temperature compensation screen. They are T. COMPENSATION: OFF, T. COMPENSATION: MANUAL and T. COMPENSATION.: AUTO as described below:

OFF: It closes the temperature compensation function; therefore, it will not show the temperature measurement. The 19036 panel shows the DUT's resistance under the measurement temperature at the time when OFF is set.

MANUAL: This function opens for users to input the temperature t(°C). Other thermos can be used to enter the environment temperature at present when the temperature probe is not available. The value is adjusted by numeric keys. The 19036 panel shows the resistance that converted to the base temperature.

MEASURE : This function needs to work with temperature probe. It will perform measurement automatically and show the environment temperature. The 19036 panel shows the resistance at what time the present environment temperature converted to the base temperature (the temperature set in BASE TEMP. under T. COMPENSATION) when AUTO is set.

4.7.4.4 Usage of Temperature Compensation in DCR Mode

The function of temperature compensation is to use the wire such as the copper wire or aluminum wire to get the resistance of a certain temperature (for instance 30°C is 100Ω) and a known temperature coefficient (such as 3930PPM) to calculate the resistance when at another temperature (such as 20°C).

1. Formula of Temperature Compensation

$$R_{t0} = R_t \{ 1 + \alpha t_0 * (t - t_0) \}$$

where

R_{t0}: It is the base temperature resistance to be converted (default is 20°C.)

R_t: It is the resistance measured under environment temperature.

α_{t0}: It is the temperature coefficient of base temperature.

t(°C): It is environment temperature.

t₀ (°C): It is the base temperature to be converted.

2. Example:

In this example the environment temperature is 30°C and the measured copper wire resistance is 100 Ω. To calculate the resistance at the temperature 20°C, users need to input the temperature to be converted (20°C) and the temperature coefficient (when the conductivity coefficient closes to 1 the temperature coefficient of copper is 3930 ppm.)

The calculation condition is that the resistance of copper wire measured is 100Ω under the environment temperature 30°C. The process of converting the 3930 ppm temperature coefficient to the resistance at 20°C is shown below.

R_{t0}: unknown resistance

R_t: 100Ω

α_{t0}: 3930 ppm

t(°C): 30 °C

t₀ (°C): 20°C

$$R_{t0} = R_t / \{1 + \alpha_{t0} * (t - t_0)\} = 100 / \{1 + (3930e-6) * (30 - 20)\} = 96.21\Omega$$

Now the 19036 shows the resistance is 96.21Ω when at 20°C.

4.7.4.5 Description of Settings

The setting of temperature coefficient is to set the base temperature for converting resistance and the wire temperature coefficient to get the resistance at base temperature.

Procedure:

1. Press **SYSTEM** → [TEST CONTROL] → [T. COMPENSATION] to go to Temperature Compensation screen.
2. Move the highlight to THERMAL COEFF. and the press numeric keys to adjust the wire temperature coefficient. Then press **ENTER**.
3. Move the highlight to BASE TEMP. and press the numeric keys to adjust the base temperature to be converted. Then press **ENTER**.

Setting MANUAL Mode:

Press **SYSTEM** → [TEST CONTROL] → [T. COMPENSATION] and select MANUAL for [T. COMPENSATION], the temperature compensation of DCR measurement in 19036 is set to MANUAL mode.

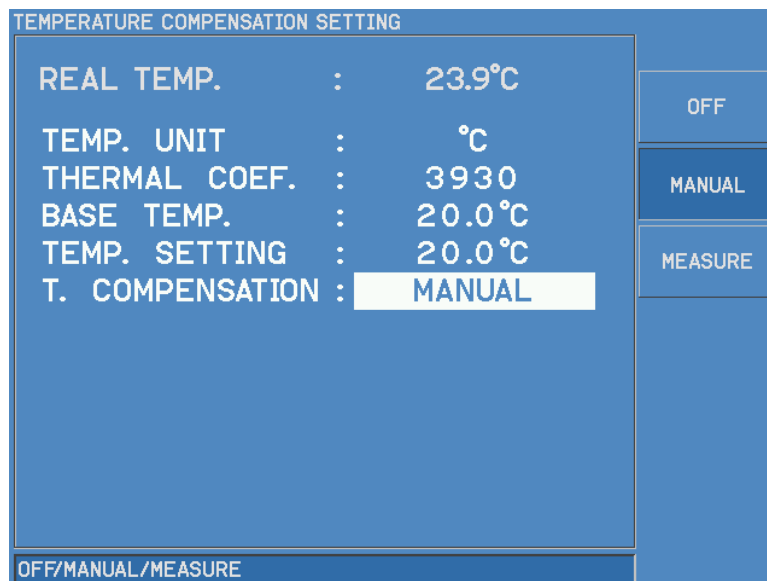

Please input the environment temperature for TEMP. SETTING. The 19036 panel shows the DCR mode measured resistance that is the one of base temperature after conversion.

Setting MEASURE Mode:

If the 19036 is installed with temperature interface and probe, it will measure and show the environment temperature automatically. Ensure the 19036 has installed the temperature interface and probe, and press **SYSTEM** → [TEST CONTROL]→ [T. COMPENSATION]. Select AUTO for [T. COMPENSATION], the temperature compensation of DCR measurement in 19036 is set to MEASURE mode.

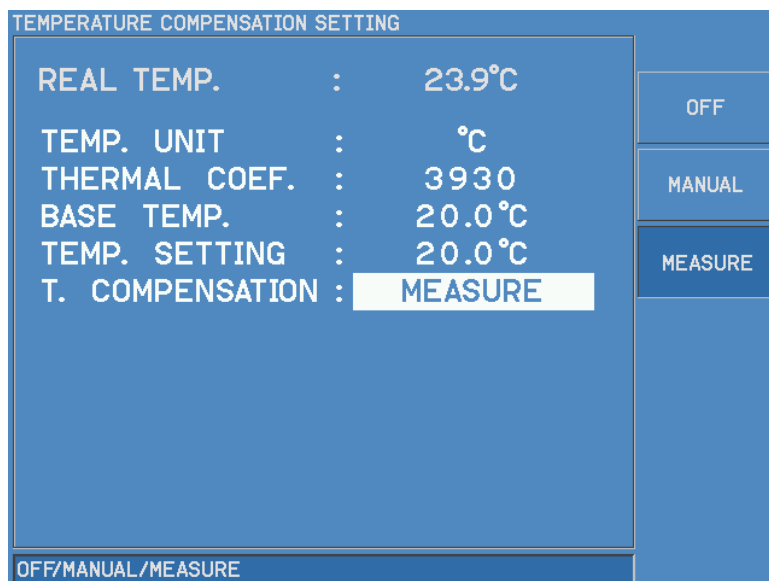

The 19036 panel shows the DCR mode measured resistance that is the one at base temperature after conversion.

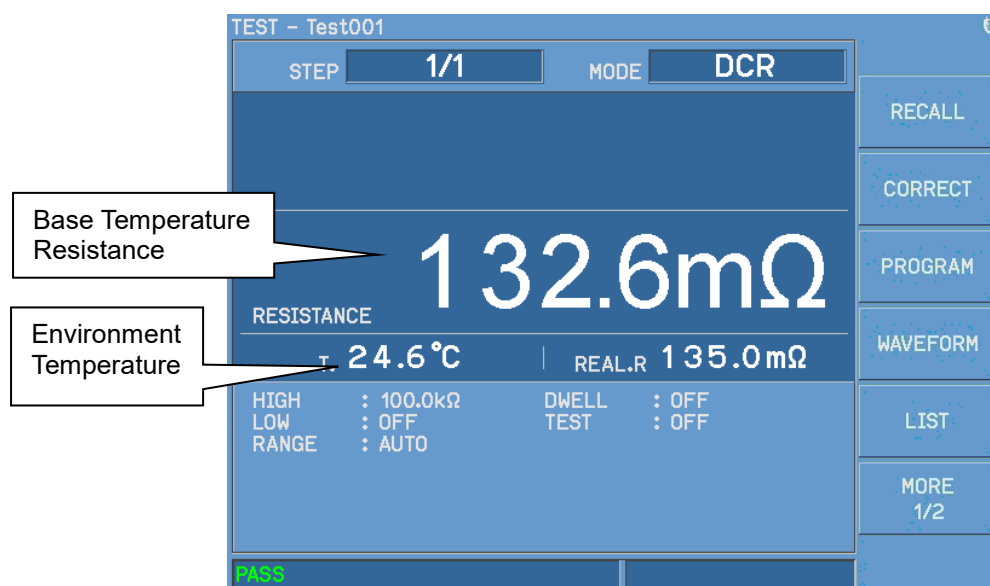

4.8 Using Open/Short Offset or Correction

4.8.1 Entering Open/Short Offset or Correction Screen

1. Press Function key [CORRECT] in power on screen to go to Open/Short Offset or CORRECTION screen as shown below:

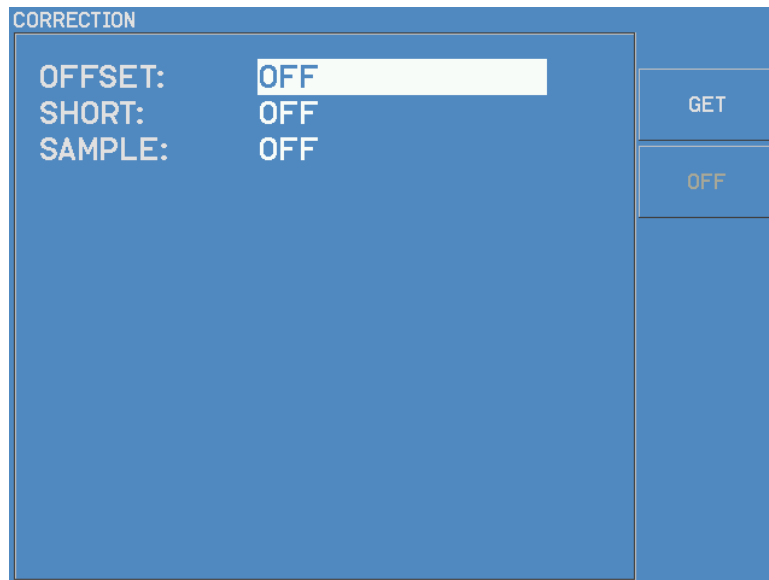

2. When the item in left area shows ON, it means the item is done and when OFF appears, it means the item is not done yet. If UNDEFINE is appeared, it indicates there is no need to execute this item.
3. Press ▲ ▼ to move the highlight to the desired function and press Function key [GET] to select the function.

4.8.2 Using OPEN CIRCUIT

1. When in CORRECTION screen, press ▲ ▼ to move the highlight to OFFSET and press Function key [GET] to go to OPEN CIRCUIT screen as shown below:

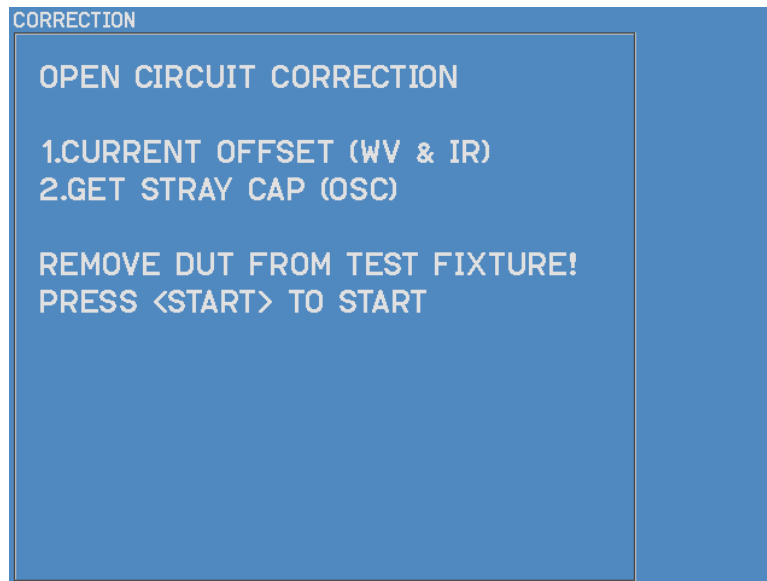

2. OPEN CIRCUIT is to offset the leakage current of AC / DC / IR MODE test lead and fixture as well as to offset the leakage capacitance in OSC MODE.
3. Remove the fixture from the DUT and press **START** to offset the leakage current or capacitance for related test items.

4.8.3 Using SHORT CIRCUIT

1. When in CORRECTION screen, press **▲** **▼** to move the highlight to SHORT and press Function key [GET] to go to SHORT CIRCUIT screen as shown below:

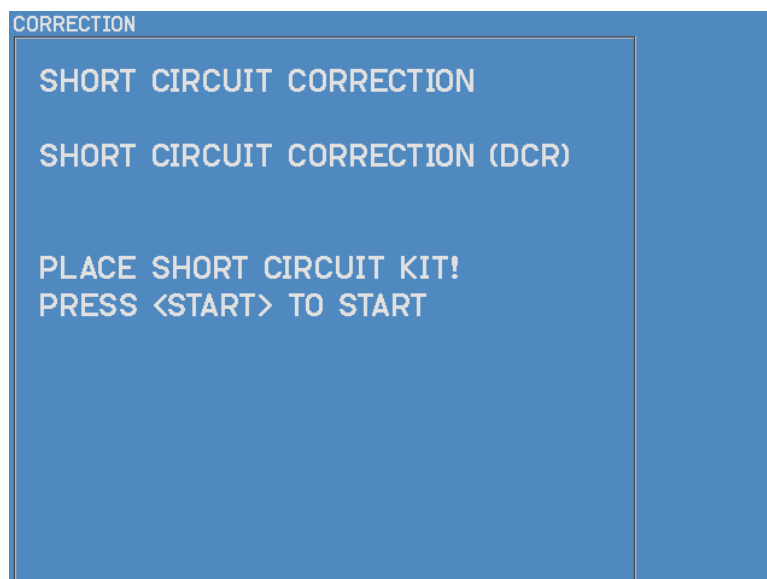

2. SHORT CIRCUIT is to do short circuit offset for DCR.
3. Short-circuit the DCR test fixture and press **START** to do DCR short circuit offset.

4.8.4 Using SAMPLE TEST

1. When in CORRECTION screen, press **▲** **▼** to move the highlight to SAMPLE and press Function key [GET] to go to SAMPLE TEST screen as shown below:

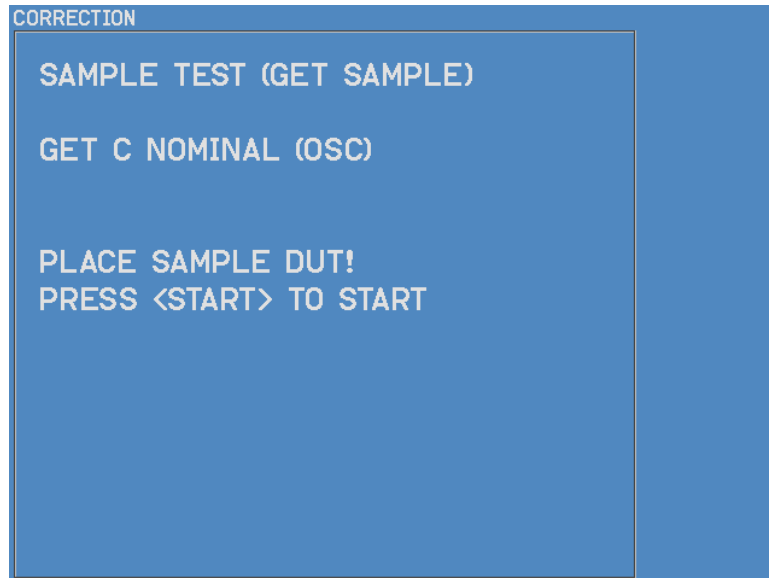

2. SAMPLE TEST is to read the standard values as the DUT judgment criteria for test in OSC mode.
3. Connect the DUT as test standard in OSC mode, press **START** to read the standard value for test in OSC mode.



Please refer to section 4.7.3 for detail description of SAMPLE GET in IWT mode.

4.9 Setting and Using SUB Step

4.9.1 Setting SUB Step

Follow the steps below to set the Sub Step

1. Press Function key [PROGRAM] and the reversed cursor stops at the STEP to add SUB. Press Function key [MORE 1/2] and [NEW SUB], it will appear the 1st SUB setting screen of the STEP.
2. Follow the step above to set the 2nd and 3rd SUB STEP and so forth.
3. The message displayed in STEP indicates the setting screen of STEP/SUB, for instance "2.1/3+5" in the figure below, 2.1 means the setting screen is the 1st SUB of 2nd STEP and 3+5 means there are 3 STEP/5 SUB.

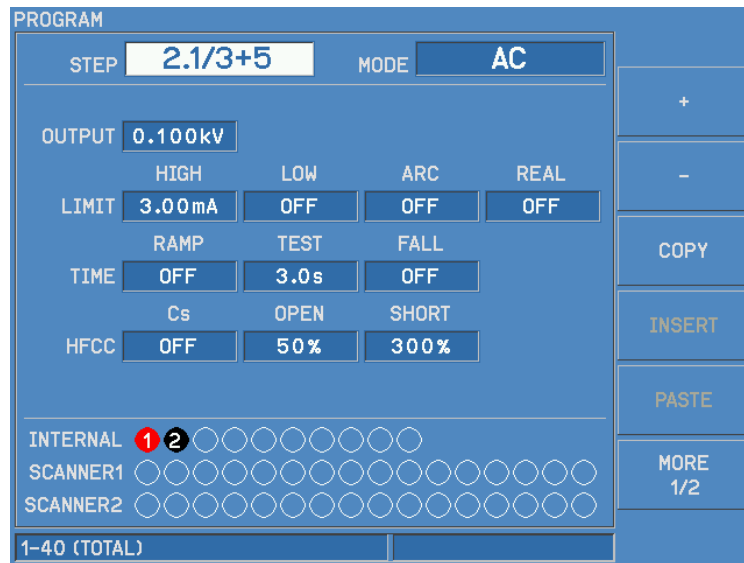

Table 4-4 Correlation of SUB STEP and AFTER FAIL Setting

Setting TEST CONTROL	Test Result	Execution Status
Set AFTER FAIL to STOP	Main Step judges as Fail	It starts Sub Step test.
		It stops test when Sub Step is judged as Fail.
		It does not start the next Main Step test when all Sub Steps are done. (All Sub Steps are judged as Pass).
	Main Step judges as Pass	It does not start Sub Step test. It starts the next Main Step test.
Set AFTER FAIL to CONTINUE	Main Step judges as Fail	It starts the Sub Step test. It continues to test the next Sub Step when the Sub Step is judged as Fail.
		It starts the next Main Step test.
	Main Step judges as Pass	It does not start the Sub Step test. It starts the next Main Step test.

- The application of SUB STEP
The Main Step can test multiple DUTs at the same time. When the Main Step is judged as Fail, it will execute the Sub Step of this Main Step to a more complete judgment result. If the Main Step is judged as Pass then it will not conduct the Sub Step of this Main Step to reduce the test time.

4.10 Conducting the Test

4.10.1 Connecting the DUT

First ensure there is no voltage output and the DANGER LED is off. Connect the low potential test cable (black) to the EST Analyzer RTN/LOW terminal and secure the clamp. Short-circuit the test cable and high voltage output terminal and ensure there is no high voltage output. Next, plug in the high voltage test cable (red or white) to high voltage output terminal. Then connect the low potential test cable to DUT and the high potential test cable to DUT.

4.10.2 Test Procedure for AC/DC

1. Connect the DUT properly.
2. The standby menu shows:

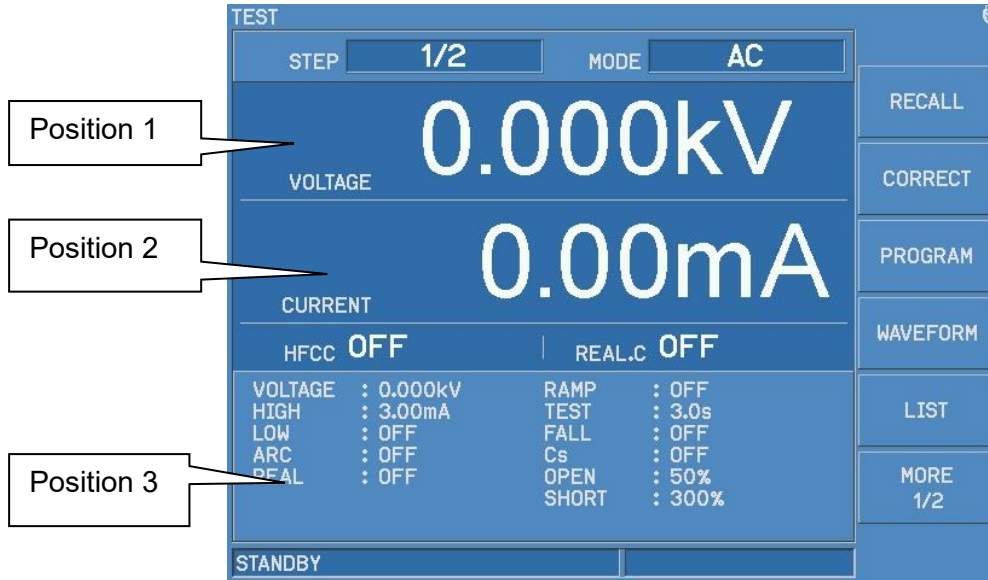

Illustration:

STEP 1/2 means there are 2 test steps and it is running the 1st test step at present. AC indicates the test mode. "Position 1" indicates the set voltage, "Position 2" is the high limit set for current, while "Position 3" is the test time. The status line shows the test result.

3. If the voltage setting is changed, press [CORRECT] to do OFFSET calibration.
4. Press **STOP** to prepare for the test. The status line shows "STANDBY".
5. Press **START** to activate the test
When this key is pressed it starts to output voltage and the DANGER LED is on. The status line shows "UNDER TEST" to warn it is in test state with voltage output. "Position 1" will show the output voltage value, "Position 2" will show the current readings and the timer on status line will start to count down.
6. GOOD Judgment
When all tests are done and the results show PASS, the EST Analyzer will see the DUT as a GOOD product and cutoff the output. The HANDLER interface outputs PASS signal and the beeper act at the same time.
7. NO GOOD Judgment
If the test value is abnormal, the EST Analyzer judges it as FAIL and cutoff the output immediately. The HANDLER outputs FAIL signal and the beeper act at the same time until the **STOP** key on the EST Analyzer is pressed. The test result will show FAIL state.

FAIL State:

Test Result	Meaning
HIGH FAIL	The current/resistance measured exceeds the range or the set high limit.

LOW FAIL	The current/resistance measured exceeds the range or the set low limit.
ARC FAIL	The current arc exceeds the high limit.
GFI FAIL	The grounding fails and interrupted.
REAL HIGH FAIL	The real current measured exceeds the range or the set high limit.
OUTPUT FAIL	The output voltage is unable to reach 95% or exceed 110%+0.02kV of the set value.
OPEN FAIL	The high frequency contact check exceeds the high limit of OPEN setting value.
SHORT FAIL	The high frequency contact check exceeds the low limit of SHORT setting value.

To stop test output in any condition, just press **STOP**.

4.10.3 Test Procedure for IR

1. Connect the DUT properly.
2. The standby menu shows:

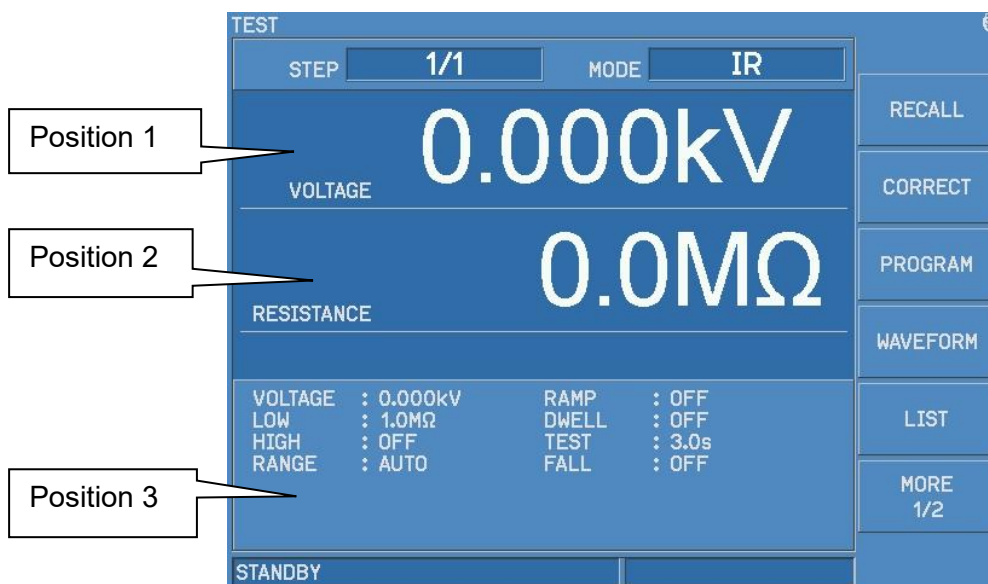

Illustration:

IR means it is in Insulation Resistance test mode. “Position 1” is the output voltage at present and “Position 2” is the read resistance at present, while “Position 3” shows the PROGRAM setting. The status line shows the test result.

3. Press **STOP** to prepare for the test. The status line shows “STANDBY”.
4. Press **START** to activate the test
When this key is pressed it starts to output voltage and the DANGER LED is on. Next the test line will show the test result and “Position 1” shows the voltage output value. “Position 2” shows the current reading and the timer on status line will start to count down.
5. GOOD Judgment
When all tests are done and the results show PASS, the EST Analyzer will see the DUT

as a GOOD product and cutoff the output. The HANDLER interface outputs PASS signal and the beeper acts at the same time.

6. NO GOOD Judgment

If the test value is abnormal, the EST Analyzer judges it as FAIL and cutoff the output immediately. The HANDLER outputs FAIL signal and the beeper acts at the same time until the **STOP** key on the EST Analyzer is pressed. The test result will show FAIL state.

FAIL State:

Test Result	Meaning
HIGH FAIL	The current/resistance measured exceeds the range or the set high limit.
LOW FAIL	The current/resistance measured exceeds the range or the set low limit.
GFI FAIL	The grounding fails and interrupted.
OUTPUT FAIL	The output voltage is unable reach 95% or exceed 110%+0.02kV of the set value.

To stop test output in any condition, just press **STOP**.

4.10.4 Test Procedure for DCR

1. Connect the DUT properly.
2. The standby menu shows:



Illustration:

DCR means it is in DC Resistance measurement mode. “Position 1” is the reading of DCR at present and “Position 2” is the PROGRAM setting. The test result is on the status line.

3. Press **STOP** to prepare for the test. The status line shows “STANDBY”.
4. Press **START** to activate the test
When this key is pressed it starts to output voltage and the DANGER LED is on. Next the status line will show the test result and “Position 1” shows the DCR reading.

5. GOOD Judgment
When all tests are done and the results show PASS, the EST Analyzer will see the DUT as a GOOD product and cutoff the output. The HANDLER interface outputs PASS signal and the beeper acts at the same time.
6. NO GOOD Judgment
If the test value is abnormal, the EST Analyzer judges it as FAIL and cutoff the output immediately. The HANDLER outputs FAIL signal and the beeper acts at the same time until the **STOP** key on the EST Analyzer is pressed. The test result will show FAIL state.

Fail State:

Test Result	Meaning
HIGH FAIL (RANGE ERROR)	No suitable range has been found when the test ends.
HIGH FAIL (TOTAL TIME TOO SHORT)	The DCR measurement is not finished when the test ends.
HIGH FAIL	The measured DC resistance exceeds the high limit of set value.
LOW FAIL	The measured DC resistance exceeds the low limit of set value.

- Note**
1. Every time the wiring material or fixture is changed for DCR measurement, be sure to run DCR SHORT CIRCUIT CORRECTION in advance to ensure the test accuracy.
 2. Refer to 4.8.3 *Using SHORT CIRCUIT* for using DCR SHORT CIRCUIT CORRECTION.
 3. The DWELL+TEST time must be larger than the time of 0.4s+SWITCH T; otherwise, an error message "TOTAL TIME TOO SHORT" will appear.

4.10.5 Test Procedure for IWT

1. Connect the DUT properly.
2. The standby menu shows:

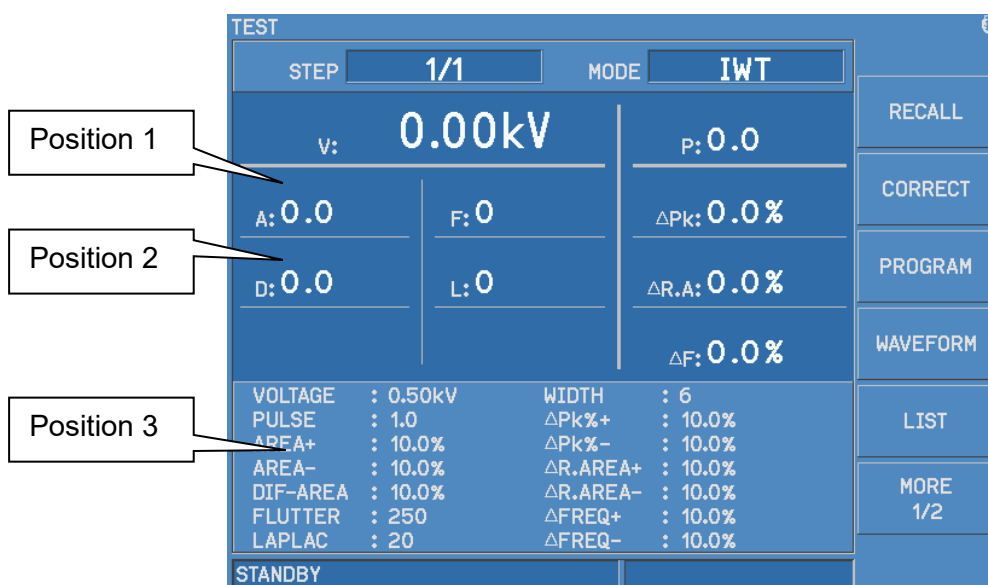

Illustration:

IWT means it is in impulse winding test mode. "Position 1" is the output voltage, "Position 2" is the condition test value for IWT judgment, while "Position 3" shows the PROGRAM setting. The test result is on the status line.

3. Press Function key [WAVEFORM] and the screen displays as below:

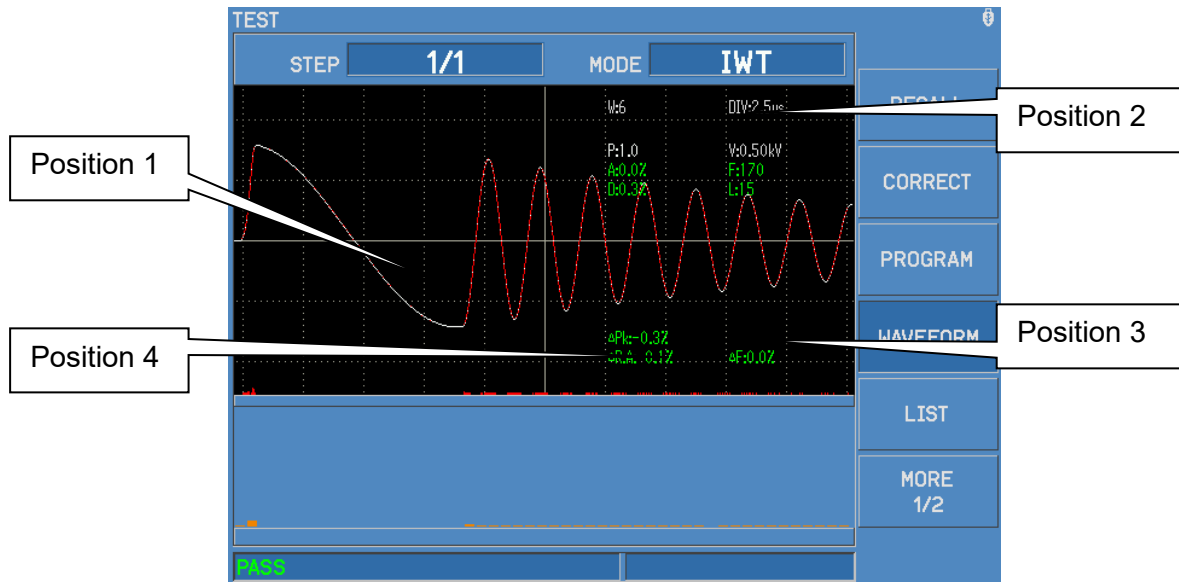

Illustration:

IWT means it is impulse winding test mode.

"Position 1" shows the SAMPLE waveform in red and DUT waveform in white.

"Position 2" shows the assistant grid set for displaying waveform and each grid indicates the time width.

"Position 3" shows the output voltage.

"Position 4" shows the test value of judgment condition. The test result is on the status line.

4. Press **STOP** to prepare for the test. The status line shows "STANDBY".
5. Press **START** to activate the test
When this key is pressed it starts to output voltage and the DANGER LED is on. The status line shows "TESTING" to warn it is in test state with voltage output.
6. GOOD Judgment
When all tests are done and the results show PASS, the EST Analyzer will see the DUT as a GOOD product and cutoff the output. The HANDLER interface outputs PASS signal and the beeper acts at the same time.
7. NO GOOD Judgment
If the test value is abnormal, the EST Analyzer judges it as FAIL and cutoff the output immediately. The HANDLER outputs FAIL signal and the beeper acts at the same time until the **STOP** key on the EST Analyzer is pressed. The test result will show FAIL state.

Fail State:

Test Result	Meaning
AREA FAIL	The test result is over the limit of area comparison.
DIF-AREA FAIL	The test result is over the limit of differential area comparison.
FLUTTER FAIL	The test result is over the limit of Flutter.
LAPLAC FAIL	The test result is over the limit of Laplacian
Δ Pk% FAIL	The test result is over the delta peak ratio limit.
Δ R.AREA FAIL	The test result is over the delta resonant area limit.
Δ FREQ FAIL	The test result is over the delta resonant frequency limit.

To stop test output in any condition, just press **STOP**.

- Note**
1. It is necessary to run SAMPLE GET when testing a new DUT or replacing one. Read the voltage waveform as the standard value for impulse winding test.
 2. Please refer to 4.7.3 for the detailed description of IWT SAMPLE GET.
 3. If there are several fail states, the status line will show one based on the table above.

4.10.6 Test Procedure for Δ/Y DCR

1. Connect the DUT properly.
2. The power on screen shows:



Illustration:

Δ/Y DCR indicates it is in Δ/Y DC Resistance mode for testing. “Position 1” shows the readings of DC resistance and “Position 2” shows the PROGRAM settings. The test result is shown on the message line.

3. Press **STOP** to prepare for the test. The status line shows “STANDBY”.
4. Press **START** to activate the test
When this key is pressed, it starts testing and the DANGER LED is on. The status line shows the test result and “Position 1” will show the Rab, Rbc and Rca DC resistance reading.

5. GOOD Judgment
When all tests are done and the results show PASS, the EST Analyzer will see the DUT as a GOOD product and cutoff the output. The HANDLER interface outputs PASS signal and the beeper acts at the same time.
6. NO GOOD Judgment
If the test value is abnormal, the EST Analyzer judges it as FAIL and cutoff the output immediately. The HANDLER outputs FAIL signal and the beeper acts at the same time until the **STOP** key on the EST Analyzer is pressed. The test result will show FAIL state.

Fail State:

Test Result	Meaning
HIGH FAIL (RANGE ERROR)	No suitable range has been found when the test ends.
HIGH FAIL (TOTAL TIME TOO SHORT)	The Δ/Y DCR measurement is not finished when the test ends.
HIGH FAIL	The measured Δ/Y DC resistance exceeds the high limit of set value
LOW FAIL	The measured Δ/Y DC resistance exceeds the low limit of set value.
DCR BALANCE FAIL	The measured Δ/Y DC resistance is unbalance that exceeds the high limit of set value.

4.10.7 Test Procedure for IWT COMPARE

1. Connect the DUT properly.
2. The power on screen shows:

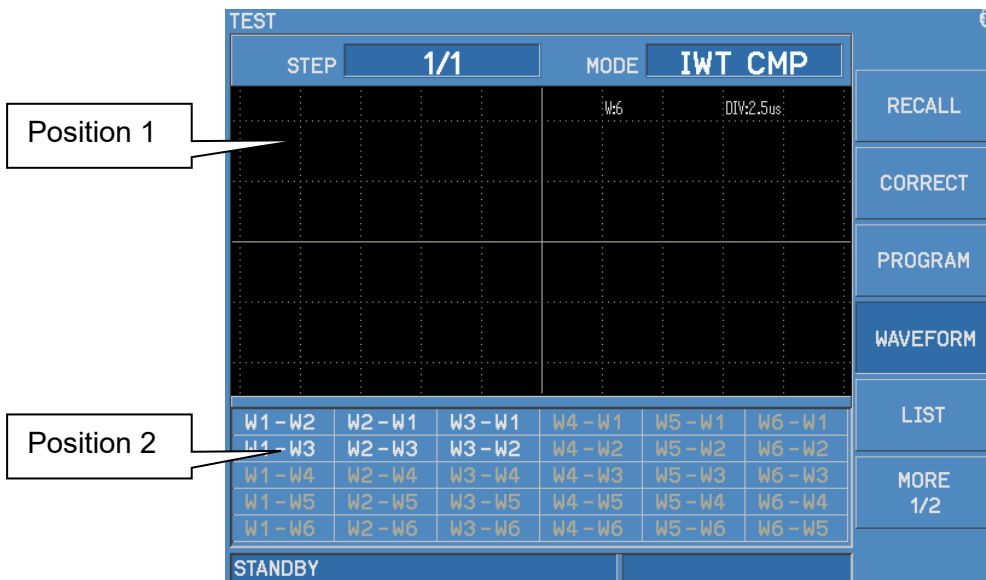
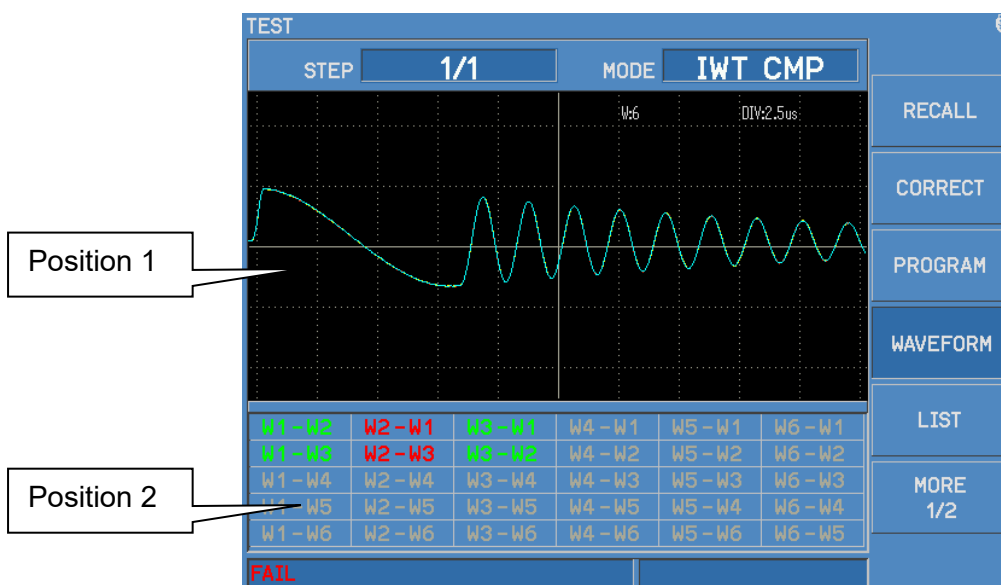

Illustration:

IWT CMP means it is impulse winding test compare mode. "Position 1" shows the voltage waveform and "Position 2" is the compared result of each winding. Press **ENTER** to go to position 2 selecting the compared result of different windings. The white

indicates the windings for comparison (windings with output channel set) while the gray indicates windings without comparison (windings without setting output channel).

3. Press **STOP** to prepare for the test. The status line shows “STANDBY”.
4. Press **START** to activate the test
When this key is pressed it starts to output voltage and the DANGER LED is on. The status line shows a “TESTING” warning to inform the user it is in test and has voltage output.
5. PASS/FAIL Judgment
The IWT COMPARE mode can set a maximum of 6 windings and PASS is judged only when the compared results of all windings are pass. If one of them is fail, it is judged as FAIL.
6. GOOD Judgment
When all tests are done and the results show PASS, the EST Analyzer will see the DUT as a GOOD product and cutoff the output. The HANDLER interface outputs PASS signal and the beeper acts at the same time.
7. NO GOOD Judgment
If the test value is abnormal, the EST Analyzer judges it as FAIL and cutoff the output immediately. The HANDLER outputs FAIL signal and the beeper acts at the same time until the **STOP** key on the EST Analyzer is pressed.
8. Press **START** to get the output result as the figure shown below. The winding test waveform will show on “Position 1” where the waveform of winding 1 is in red, winding 2 is in yellow, winding 3 is in blue, winding 4 is in orange, winding 5 is in green, and winding 6 is in purple. The “Position” 2 shows the compared results of windings where green means PASS and red means FAIL. The message line on the lower left corner will show PASS if all results are PASS; otherwise, it will show FAIL.



9. Press **ENTER** to go to “Position 2” and use arrow keys to select the compared test results of different windings. The compared voltage waveform of two windings is shown in “Position 1”. The winding name on the left of “-” is the comparison baseline and on the

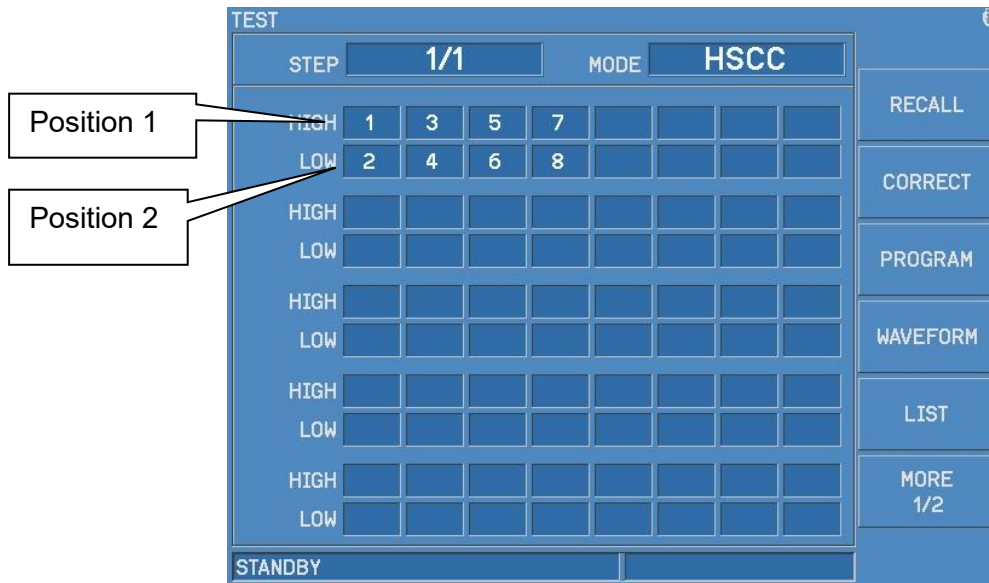

Illustration:

HSCC means it is in high speed contact check measurement mode. “Position 1” sets the high potential channel to be on and “Position 2” sets the low potential channel to be on.

3. Press **STOP** to prepare for the test. The status line shows “STANDBY”.
4. Press **START** to activate the test
When this key is pressed it starts to output voltage and the DANGER LED is on. The status line shows the test result.
5. GOOD Judgment
When all tests are done and the results show PASS, the EST Analyzer will see the DUT as a GOOD product and cutoff the output. The HANDLER interface outputs PASS signal and the beeper acts at the same time.
6. NO GOOD Judgment
If the test value is abnormal, the EST Analyzer judges it as FAIL and cutoff the output immediately. The HANDLER outputs FAIL signal and the beeper acts at the same time until the **STOP** key on the EST Analyzer is pressed. The test result will show FAIL state.

Fail State:

Test Result	Meaning
OPEN FAIL	The result of high speed contact check is open.

4.10.9 Test Procedure for OSC

1. Connect the DUT properly.
2. The standby menu shows:

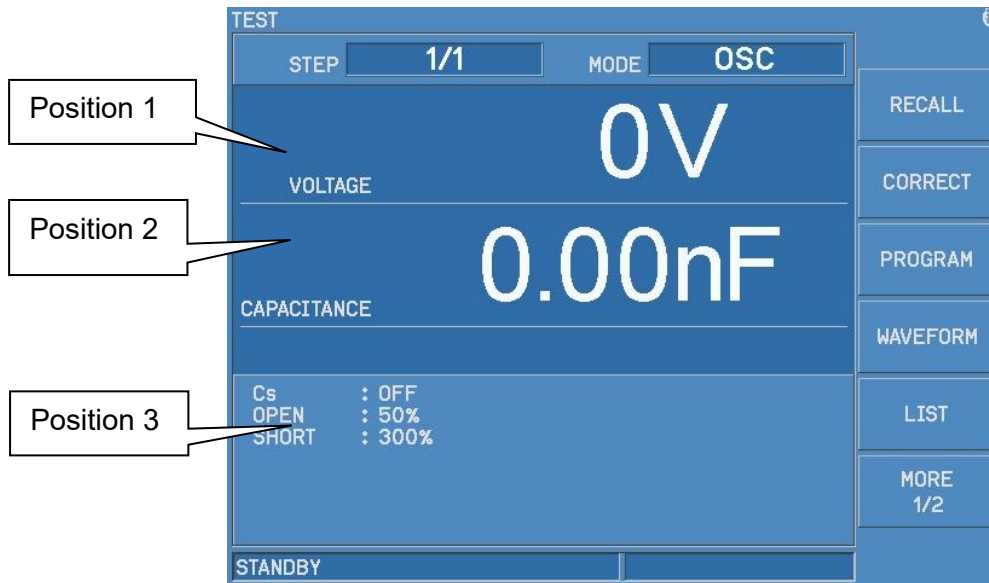

Illustration:

OSC means it is in Open Short Check mode. “Position 1” is the output voltage while “Position 2” is the capacitance read, while “Position 3” shows the PROGRAM setting. The test result shows in status line.

3. Press **STOP** to prepare for the test. The status line shows “STANDBY”.
4. Press **START** to activate the test
When this key is pressed it starts to output voltage and the DANGER LED is on. The status line shows “UNDER TEST” to warn it is in test state with voltage output. “Position 1” shows the output voltage value and “Position 2” shows the capacitance readings.
5. GOOD Judgment
When all tests are done and the results show PASS, the EST Analyzer will see the DUT as a GOOD product and cutoff the output. The HANDLER interface outputs PASS signal and the beeper acts at the same time.
6. NO GOOD Judgment
If the test value is abnormal, the EST Analyzer judges it as FAIL and cutoff the output immediately. The HANDLER outputs FAIL signal and the beeper acts at the same time until the **STOP** key on the EST Analyzer is pressed. The test result will show FAIL state.

Fail State:

Test Result	Meaning
OPEN FAIL	Open circuit, the capacitance reading is smaller than the OPEN setting.
SHORT FAIL	Short circuit, the capacitance reading is larger than the SHORT setting.

To stop the test output in any circumstances, just press **STOP**.

- Note**
1. Every time the wiring material or fixture is changed for OSC, be sure to run OPEN CIRCUIT CORRECTION in advance to ensure the test accuracy.
 2. It is necessary to run SAMPLE TEST when replacing a new DUT for OSC. Read the capacitance from the test sample as the standard value.
 3. For OPEN CIRCUIT CORRECTION in OSC, please refer to 4.8.2 *Using OPEN CIRCUIT*.
 4. For SAMPLE TEST in OSC, please refer to 4.8.4 *Using SAMPLE TEST*.

4.10.10 Test Procedure for PA

1. Connect the DUT properly.
2. The standby menu shows:

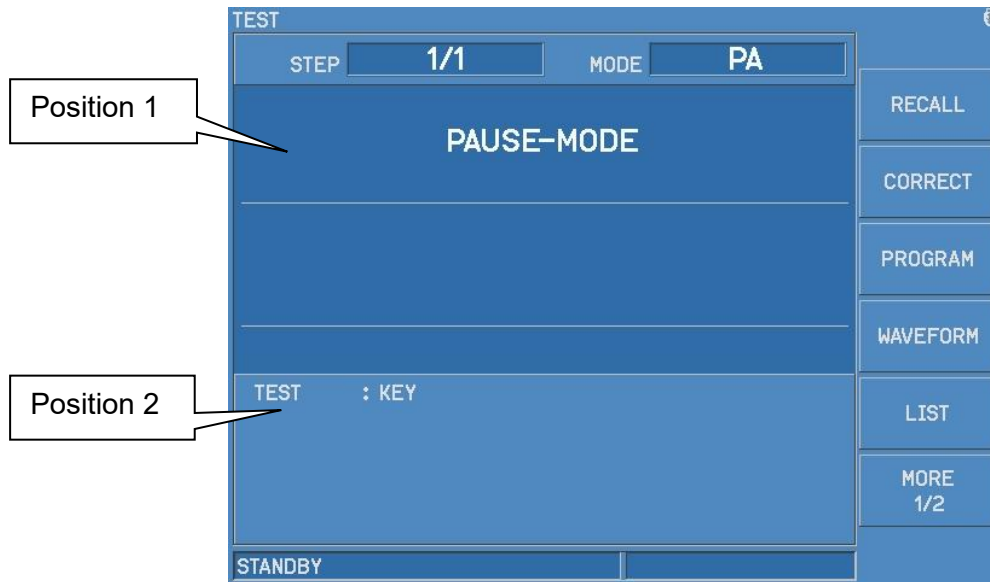

Illustration:

PA indicates it is in Pause Mode for testing. “Position 1” shows the prompt message and “Position 2” shows the time set. The test result is shown on the message line.

3. GOOD Judgment
When the PA Mode test time ends, the result will show PASS. The HANDLER interface outputs PASS signal and the beeper acts at the same time.

4.10.11 Test Procedure for Lx

1. Use an RS232 and BNC cable to connect the Transformer Tester and the EST Analyzer.
2. Turn on the Transformer Tester and set the RS232 baudrate. Press 4 under SYSTEM SETUP to enter into the < INTERFACE SETUP > screen as the figure shown below.

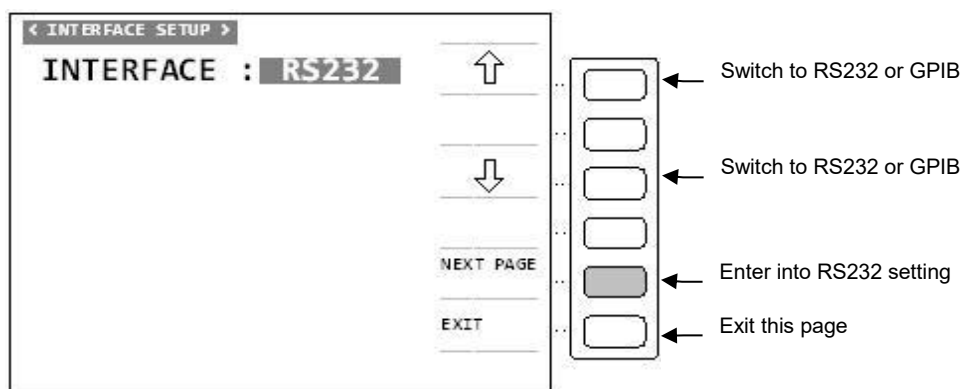

Press NEXT PAGE to enter into the BAUD RATE... settings page as the figure shown below.

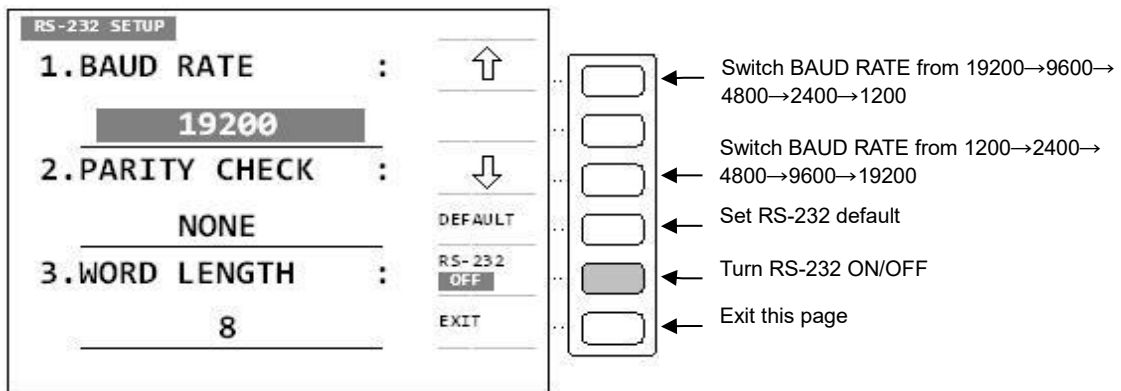

Move the highlight to BAUD RATE and press the $\uparrow\downarrow$ on the LCD to set the baudrate to 9600.

3. Enable the EST Analyzer's L COMBINE function. Move the highlight to SYSTEM CONFIG in the SYSTEM page and press **ENTER**. The settings of SYSTEM CONFIG are shown in the figure below.



Move the highlight to L COMBINE and press [ENALBE] to activate the L COMBINE function. If it is connected successfully, RS232 ON will show on the Transformer Tester screen.

Note : If one of the connected devices is restarted, the EST Analyzer has to restart the L COMBINE function.

4. Set the L CONDITIONS. Move the highlight to TEST CONTROL in the SYSTEM page and press **ENTER**. Move the highlight to L CONDITINS in the SYSTEM CONFIG page and press [SETUP] to do the settings. Refer to the 4.5.4 *Setting L CONDITIONS* for detail description.

5. The standby menu shows:

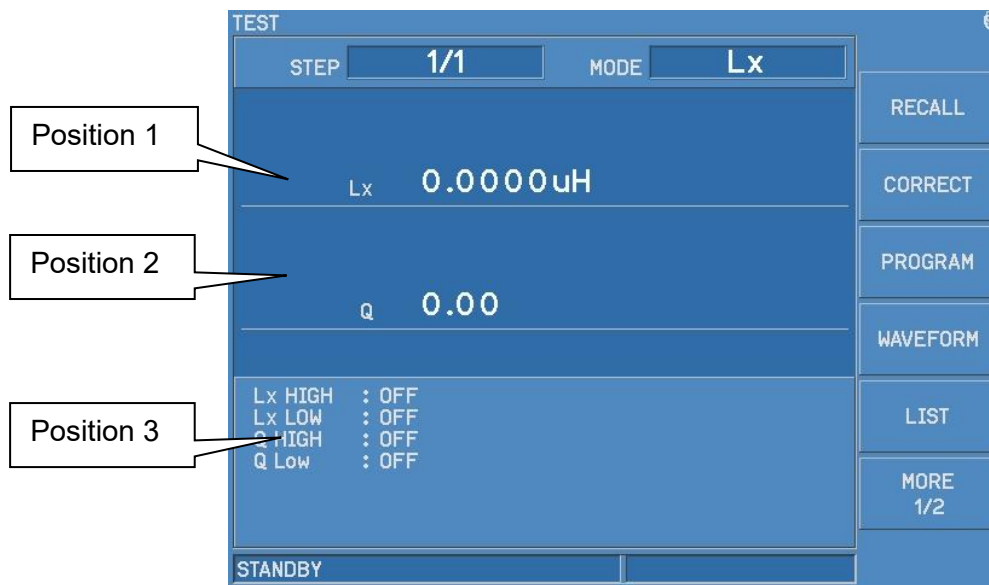

Illustration:

Lx indicates it is in Inductance Mode for testing. “Position 1” shows the measured inductance, “Position 2” shows the inductance quality factor and “Position 3” shows the PROGRAM settings. The test result is shown on the message line.

7. Press **STOP** to prepare for the test. The status line shows “STANDBY”.
8. Press **START** to activate the test
When this key is pressed it starts to output voltage and the DANGER LED is on. The status line shows “UNDER TEST” to warn it is in test state with voltage output.
9. GOOD Judgment
When all tests are done and the results show PASS, the EST Analyzer will see the DUT as a GOOD product and cutoff the output. The HANDLER interface outputs PASS signal and the beeper acts at the same time.
10. NO GOOD Judgment
If the test value is abnormal, the EST Analyzer judges it as FAIL and cutoff the output immediately. The HANDLER outputs FAIL signal and the beeper acts at the same time until the **STOP** key on the EST Analyzer is pressed. The test result will show FAIL state.

Fail State:

Test Result	Meaning
HIGH FAIL	The measured inductance or quality factor exceeds the high limit of set value.
LOW FAIL	The measured inductance or quality factor exceeds the low limit of set value.
OPEN FAIL	The open circuit fixture compensation is failed
SHORT FAIL	The short circuit fixture compensation is failed.

To stop the test output in any circumstances, just press **STOP**.

4.10.12 Test Procedure for Lx BALANCE

1. Use an RS232 and BNC cable to connect the Transformer Tester and the EST Analyzer. See 4.10.11 *Test Procedure for Lx* for the settings.
2. The standby menu shows:



Illustration:

Lx BL indicates it is in Inductance Balance Mode for testing. "Position 1" shows the absolute value or percentage of the measured inductance error. "Position 2" shows the PROGRAM settings. The test result is shown on the message line.

3. Press **STOP** to prepare for the test. The status line shows "STANDBY".
4. Press **START** to activate the test
When this key is pressed it starts to output voltage and the DANGER LED is on. The status line shows "UNDER TEST" to warn it is in test state with voltage output.
5. GOOD Judgment
When all tests are done and the results show PASS, the EST Analyzer will see the DUT as a GOOD product and cutoff the output. The HANDLER interface outputs PASS signal and the beeper acts at the same time.
6. NO GOOD Judgment
If the test value is abnormal, the EST Analyzer judges it as FAIL and cutoff the output immediately. The HANDLER outputs FAIL signal and the beeper acts at the same time until the **STOP** key on the EST Analyzer is pressed. The test result will show FAIL state.

Fail State:

Test Result	Meaning
HIGH FAIL	The test result exceeds the high limit of set value.
LOW FAIL	The test result exceeds the low limit of set value.

To stop the test output in any circumstances, just press **STOP**.

4.10.13 Test Procedure for EXTERIOR CONNECT

1. Connect the DUT properly.
2. The standby menu shows:

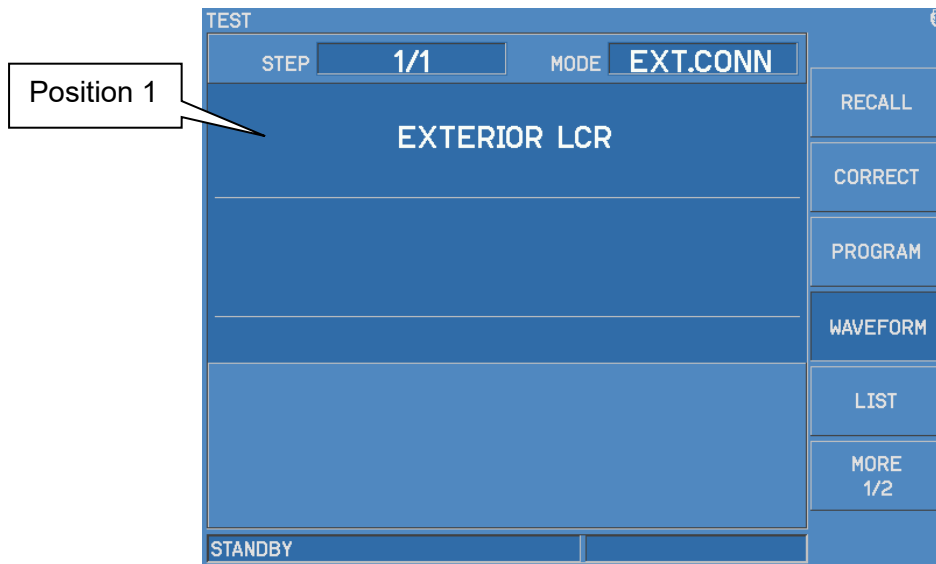

Illustration:

EXT.CONN indicates the test mode is in exterior connection mode. "Position 1" shows the EXTERIOR CONNECT message. The test result is shown on the message line.

1. Press **STOP** to prepare for the test. The status line shows "STANDBY".
2. Press **START** to activate the test
When this key is pressed, the set channel will connect the BNC terminal on the rear panel, and the exterior connected device will be used with this analyzer to perform testing. When the message shows "PRESS START KEY TO CONTINUE", press **START** to conduct next step.
3. GOOD Judgment
It will show PASS when the EXTERIOR CONNECT test is done. The HANDLER interface will output a PASS signal and the buzzer will beep at the same time.

4.10.14 WV AUTO RANGE

1. Set the **WV AUTO RANGE** to **ON**.
2. As Position 1 shows in the figure below it is set to high potential range.



3. If the tested current is in low potential range at 0.6 seconds before the test ends, the current range as Position 1 showed above will switch to low potential range automatically.



4.11 Scan Test

The EST Analyzer is able to perform multiple dots scanning for fast and efficiency test.

1. When in program setting screen, set the programs accordingly.
2. Move the highlighted to "INTERNAL", "SCANNER1", "SCANNER2" and press Function key [NONE], [HIGH] and [LOW] to set the scan test output states which are open, high voltage output and low voltage output.
3. When done press **TEST** to confirm and exit.



The EST Analyzer has no default output channel. To begin the test please set one high voltage output channel at least.

4.12 EXPORT Function

The EST Analyzer is able to save the test procedure and results of a PROGRAM in text to a USB flash disk. The file is saved in CSV (Comma Separated Values) format via the following steps.

1. In standby menu, press Function key [MORE1/2] and the screen shows as below.

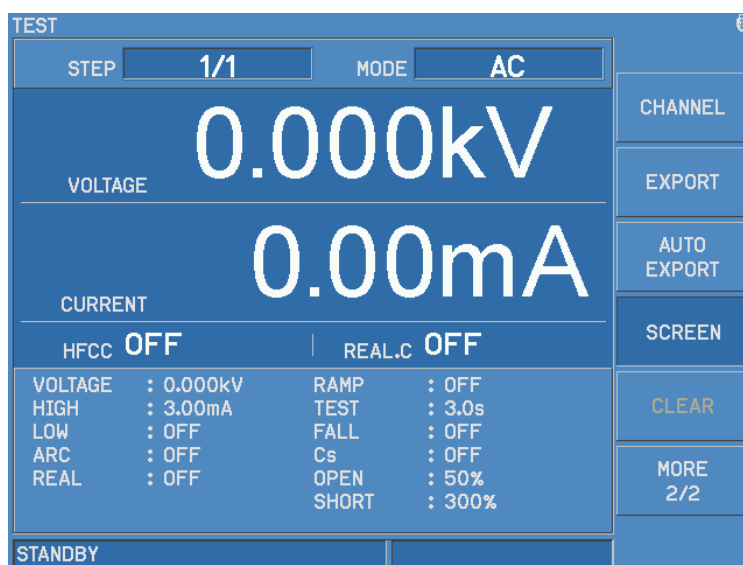

2. Insert the USB flash disk into the USB port on the front panel.
3. Press Function key [EXPORT] to save the test procedure of PROGRAM function in text to the USB flash disk under the path of \Chroma 19036\result.

4.13 AUTO EXPORT Function

The EST Analyzer is able to automatically save the test results in text report to a USB flash disk. The file is saved in CSV (Comma Separated Values) format via the following steps.

1. In standby menu, press Function key [MORE1/2] and the screen shows as below.

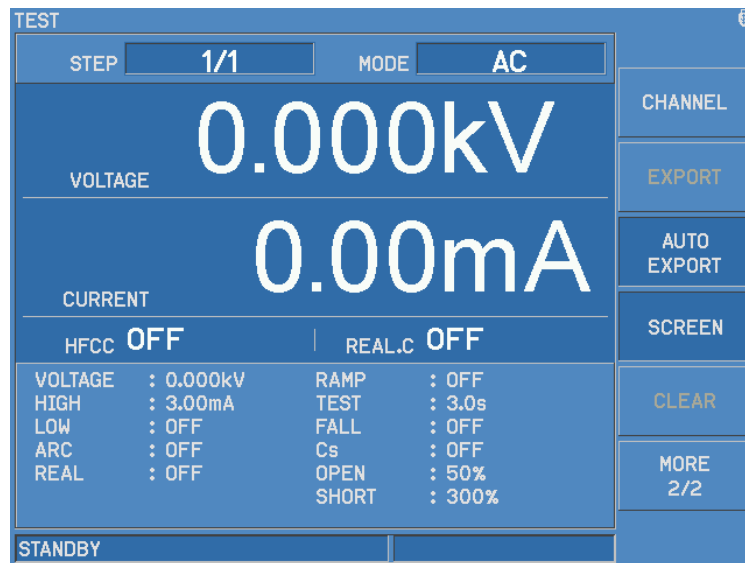

2. Insert the USB flash disk into the USB port on the front panel.
3. Press the Function key [AUTO EXPORT] and every time when the test ends it will automatically save the procedure of current PROGRAM in text to a USB flash disk under the path of Chroma 19036\result\auto export. **START** cannot be used to activate next test during saving.
4. When AUTO EXPORT function is activate, no editing can be done including PROGRAM, MAIN INDEX and SYSTEM.
5. Be sure to regularly clear the test procedure reports saved in the USB flash disk to avoid storage failure.

4.14 IWT BREAKDOWN VOLT MODE

Press **MAIN INDEX** to enter into the MEMORY and IWT BREAKDOWN VOLT MODE (IWT BDV MODE) selection page as the figure shown below.

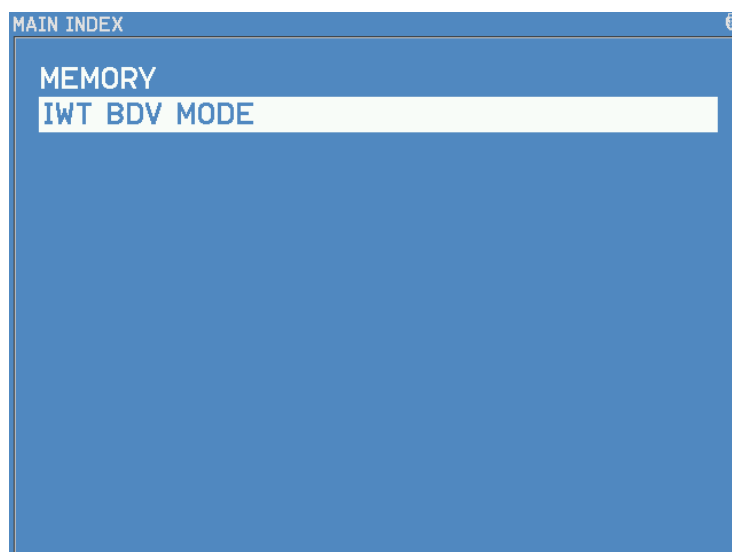

Select IWT BDV MODE and it appears as shown in the figure below. To quit the IWT BDV MODE, simply press **MAIN INDEX** again.

19036 IWT BDV MODE

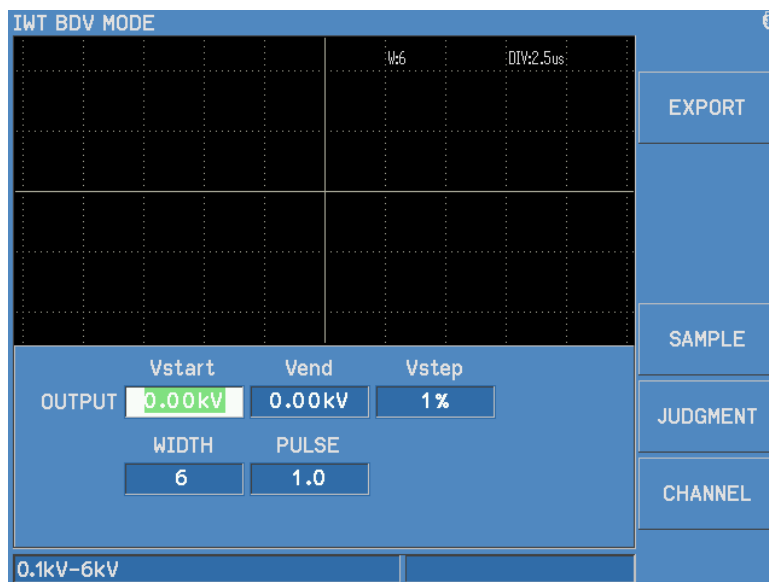

Table 4-5 19036 IWT BEARKDOWN VOLT MODE Parameters

Parameter	Range	Default	Description
Vstart	0.1kV~6kV	0V	It sets the voltage start value.
Vend	0.1kV~6kV	0V	It sets the voltage end value.
Vstep	1%~20%	1%	It sets the STEP percentage for voltage rise.
WIDTH	1~11	6	It sets the waveform sampling rate. The range is 1~11 where 1 is high speed sampling rate and 11 is low sampling rate. The smaller the number, the smaller time range displays on the screen and the larger the number, the larger time range displays on the screen.
PULSE	1.0~32.9	1.0	It sets the pulse number for testing.

Press Function key [JUDGMENT] to set the judgment condition and range of IWT BDV MODE as shown in the figure below. To exit the setting menu, press Function key [JUDGMENT].

Notice : Changing the Vstart and WIDTH settings will clear the SAMPLE waveform data. Please redo SAMPLE GET before testing.

19036 IWT BDV MODE JUDGMENT

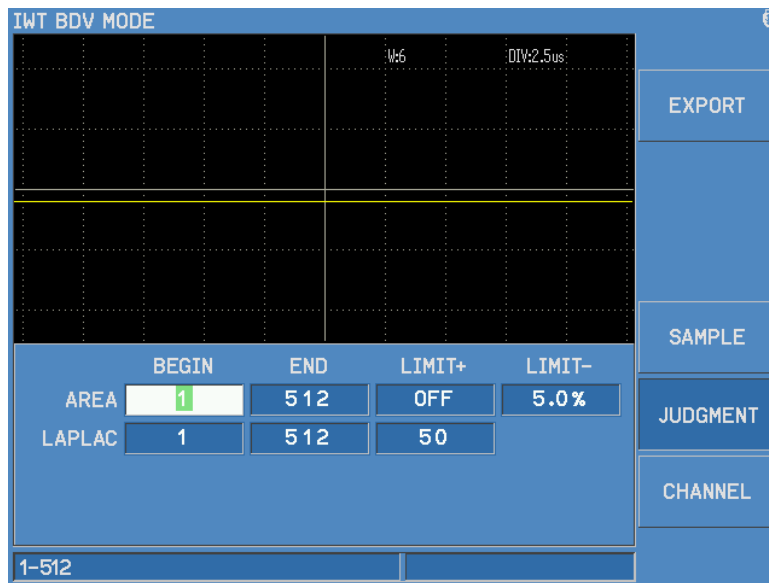

Table 4-6 19036 IWT BEARKDOWN VOLT MODE JUDGMENT Parameters

Parameter		Range	Default	Description
AREA	BEGIN	1~512	1	It sets the beginning point of area for comparison.
	END	1~512	512	It sets the end point of area for comparison.
	LIMIT+	OFF,0.1%~99.9%	OFF	It sets the maximum percentage of limit for area comparison. 0 means OFF.
	LIMIT-	OFF,0.1%~99.9%	5%	It sets the minimum percentage of limit for area comparison. 0 means OFF.
LAPLAC	BEGIN	1~512	1	It sets the beginning point of LAPLAC.
	END	1~512	512	It sets the end point of LAPLAC.
	LIMIT+	OFF, 1~9999	50	It sets the limit of LAPLAC. 0 means OFF.

Notice

The JUDGMENT parameters cannot be all OFF or it won't be able to output in IWT BDV MODE.

19036 IWT BDV MODE CHANNEL

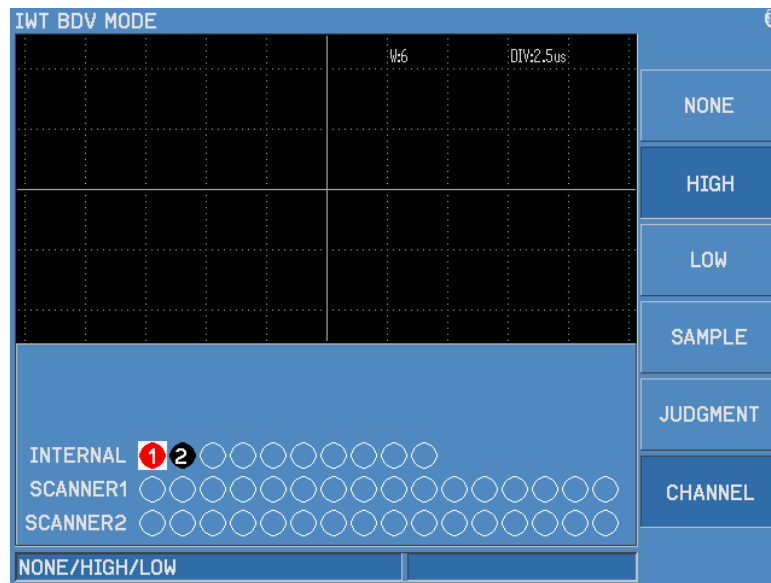

Setting the IWT BDV MODE channel output status:

- INTERNAL : It sets the output status of Tester to NONE (no output) /HIGH (high potential output) /LOW (low potential output.)
- SCANNER1: It sets the output status of test fixture 1 to NONE (no output) /HIGH (high potential output) /LOW (low potential output.)
- SCANNER2: It sets the output status of test fixture 2 to NONE (no output) /HIGH (high potential output) /LOW (low potential output.)

IWT BDV MODE

When the parameters are set in IWT BDV MODE, it needs to do SAMPLE GET first before performing the IWT BDV MODE test. Press Function key [SAMPLE] to enter into the IWT BDV MODE SAMPLE GET function as shown in the figure below.

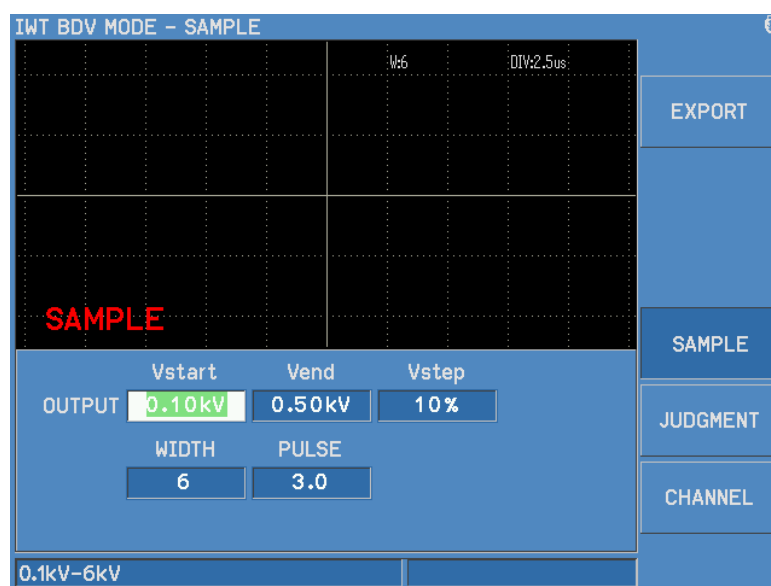

1. Press **START** in SAMPLE menu to start SAMPLE GET. The 19036 will follow the set Vstart voltage to perform SAMPLE GET as shown in the figure below.

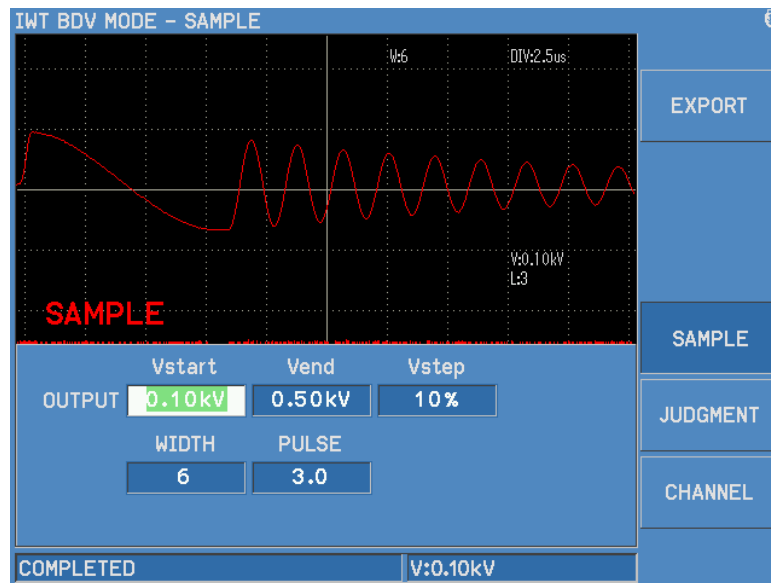

2. When SAMPLE is done, press Function key [SAMPLE] again to exit the SAMPLE menu. Press **START** to start the IWT BDV MODE testing.

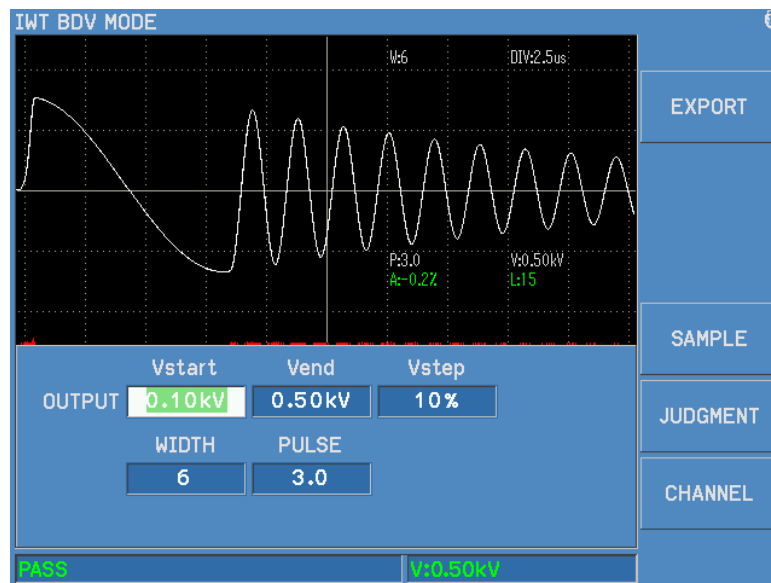

5. HANDLER Interface

5.1 Specification

5.1.1 Driving Capability

Internal Signal Output Specification: DC 24V, 20~40mA

External Signal Input Specification: DC 3V~26V (HIGH), 10mA± 4mA

5.1.2 Pin Assignment

Pin No.	Signal				Input/Output	Description
	AC	DC	IR	OSC		
1		/STN0			Output	/STN0~/STN5 signals are sent out in sequential order regardless of the Main Step or Sub Step. There are 6 bits to indicate 60 test steps and the output format is in binary. (/STN0 is low bit and /STN5 is high bit.)
2		/STN1				
3		/STN2				
4		/STN3				
5		/STN4				
6		/STN5				
7	/PASS_FAIL				Output	When TOTAL P/F sets to OFF, High means the test result is FAIL and Low means the test result is PASS.
	/TOTAL_PASS				Output	When TOTAL P/F sets to ON, it outputs Low if all test results are PASS; otherwise, it will output High.
8	/HIGH FAIL	/HIGH FAIL	/HIGH FAIL	X	Output	High means the item result is judged as PASS. Low means the item result is judged as FAIL.
9	/LOW FAIL	/LOW FAIL	/LOW FAIL	X	Output	High means the item result is judged as PASS. Low means the item result is judged as FAIL.
10	/ARC_FAIL	/ARC_FAIL	X	X	Output	High means the item result is judged as PASS. Low means the item result is judged as FAIL.
11	RESERVED				Output	Reserved pin.
12	/REAL_FAIL	X	X	X	Output	High means the item result is judged as PASS. Low means the item result is judged as FAIL.
13	/HFCC_OPEN	/HFCC_OPEN	X	/OPEN_FAIL	Output	High means the item result is judged as PASS. Low means the item result is judged as FAIL.
14	/HFCC_SHORT	/HFCC_SHORT	X	/SHORT_FAIL	Output	High means the item result is judged as PASS.

						Low means the item result is judged as FAIL.
15	/SETTING ERROR			Output		It is the signal output pin for test setting error. When the signal is low, it means the test setting is wrong. (Note)
16	/EOT			Output		When the signal is High, it indicates the test program is running. When the signal is Low, it indicates the test program is ended or in standby mode.
17	/EOS			Output		When the signal is High, it indicates the test step is running. When the signal is Low, it indicates the test step is done before going to the next or all of the steps are ended.
18	/PA			Output		The signal is High when enabled for test. Later, the /PA signal and the High or Low level of COM will change once every time it goes through the PA mode.
19,20	+VEXT			———		It is the external DC voltage input. The range of input voltage is +3V~+26V.
21,22	+24VF1			———		It is the internal DC voltage output which is +24V.
23	RESERVED			Input		Reserved pin.
24	/RECALL1			Input		/RECALL1~/RECALL3 signal indicate the read memory code. The input used 3 bits to indicate 7 sets of memory (INDEX 1 ~7). The input format is in binary (/RECALL1 is the low bit and /RECALL3 is the high bit.) 001 means to Recall memory 1. 111 means to Recall memory 7.
25	/RECALL2			Input		
26	/RECALL3			Input		
27	/E_STOP			Input		External STOP signal input when signal state is Low.
28	/E_START			Input		External START signal input when signal state is Low.
29	/LOCK			Output		Use the control air valve with A190512.
30	RESERVED			Output		Reserved pin.
31	/TOTAL_FAIL			Output		It outputs High if all test results are PASS; otherwise, it outputs Low.
32	RESERVED			Output		Reserved pin.
33,34	EXTGND			———		It is the low voltage terminal for input/output signal.
35,36	DGND			———		It is the low voltage terminal for internal voltage output.

Pin No.	Signal			Input/Output	Description
	DCR Δ/Y DCR	IWT IWT CMP	HSCC		
1		/STN0		Output	/STN0~/STN5 signals are sent out in sequential order regardless of the Main Step or Sub Step. There are 6 bits to indicate 60 test steps and the output format is in binary. (/STN0 is low bit and /STN5 is high bit.)
2		/STN1			
3		/STN2			
4		/STN3			
5		/STN4			
6		/STN5			
7	/PASS_FAIL			Output	When TOTAL P/F sets to OFF, High means the test result is FAIL and Low means the test result is PASS.
	/TOTAL_PASS			Output	When TOTAL P/F sets to ON, it outputs Low if all test results are PASS; otherwise, it will output High.
8	/HIGH FAIL	/FAIL_AREA+	X	Output	High means the item result is judged as PASS. Low means the item result is judged as FAIL.
9	/LOW FAIL	/FAIL_AREA-	X	Output	High means the item result is judged as PASS. Low means the item result is judged as FAIL.
10	/DCR_BALANCE	/FAIL_DIF-AREA	X	Output	High means the item result is judged as PASS. Low means the item result is judged as FAIL.
11	X	/FAIL_LAPLAC	X	Output	High means the item result is judged as PASS. Low means the item result is judged as FAIL.
12	X	/FAIL_FLUTTER	X	Output	High means the item result is judged as PASS. Low means the item result is judged as FAIL.
13	X	/FAIL_R.AREA	/OPEN_FAIL	Output	High means the item result is judged as PASS. Low means the item result is judged as FAIL.
14	RESERVED	/FAIL_Pk	RESERVED	Output	High means the item result is judged as PASS. Low means the item result is judged as FAIL.
15	/SETTING ERROR			Output	It is the signal output pin for test setting error. When the signal is low, it means the test setting is wrong. (Note)
16	/EOT			Output	When the signal is High, it indicates the test program is running. When the signal is Low, it indicates the test program is ended or in standby mode.

17	/EOS			Output	When the signal is High, it indicates the test step is running. When the signal is Low, it indicates the test step is done before going to the next or all of the steps are ended.
18	/PA			Output	The signal is High when enabled for test. Later, the /PA signal and the High or Low level of COM will change once every time it goes through the PA mode.
19,20	+VEXT			———	It is the external DC voltage input. The range of input voltage is +3V~+26V.
21,22	+24VF1			———	It is the internal DC voltage output which is +24V.
23	RESERVED			Input	Reserved pins
24	/RECALL1			Input	/RECALL1~/RECALL3 signal indicate the read memory code. The input used 3 bits to indicate 7 sets of memory (INDEX 1 ~7). The input format is in binary (/RECALL1 is the low bit and /RECALL3 is the high bit.) 001 means to Recall memory 1. 111 means to Recall memory 7.
25	/RECALL2			Input	
26	/RECALL3			Input	
27	/E_STOP			Input	External STOP signal input when signal state is Low
28	/E_START			Input	External START signal input when signal state is Low.
29,	/LOCK			Output	Use the control air valve with the A190512.
30	RESERVED			Output	Reserved pin.
31	/TOTAL_FAIL			Output	It outputs High if all test results are PASS; otherwise, it outputs Low.
32	RESERVED	/FAIL_FREQ	RESERVED	Output	It outputs High if all test results are PASS; otherwise, it outputs Low.
33,34	EXTGND			———	It is the low voltage terminal for input/output signal.
35,36	DGND			———	It is the low voltage terminal for internal voltage output.

Pin No.	Signal				Input/Output	Description
	PA	Lx	Lx BANLANCE	EXTERIOR CONNECT		
1			/STN0		Output	/STN0~/STN5 signals are sent in sequence without any distinction of Main Step or Sub Step. It uses 6 bits to represent 60 test steps. The output format is in binary code. (/STN0 is low bit and /STN5 it high bit.)
2			/STN1			
3			/STN2			
4			/STN3			
5			/STN4			
6			/STN5			
7			/PASS_FAIL		Output	When TOTAL P/F sets to OFF, High means the test result is FAIL and Low means the test result is PASS.
			/TOTAL_PASS		Output	When TOTAL P/F sets to ON, it outputs Low if all test results are PASS; otherwise, it will output High.
8	X	/HIGH FAIL(L)	/Lx_BALANCE	X	Output	High means the item result is judged as PASS. Low means the item result is judged as FAIL.
9	X	/LOW FAIL(L)	X	X	Output	High means the item result is judged as PASS. Low means the item result is judged as FAIL.
10	X	X	X	X	Output	High means the item result is judged as PASS. Low means the item result is judged as FAIL.
11	RESERVED				Output	Reserved pin.
12	X	X	X	X	Output	High means the item result is judged as PASS. Low means the item result is judged as FAIL.
13	X	/HIGH FAIL(Q)	/HIGH FAIL(Q)	X	Output	High means the item result is judged as PASS. Low means the item result is judged as FAIL.
14	X	/LOW FAIL(Q)	/LOW FAIL(Q)	X	Output	High means the item result is judged as PASS. Low means the item result is judged as FAIL.
15			/SETTING ERROR		Output	It is the signal output pin for test setting error. When the signal is low, it means the test setting is wrong. (Note)
16			/EOT		Output	When this signal is high, it means the program is testing. When this signal is low, it means the program is stopped or on standby.
17			/EOS		Output	When this signal is high, it means the test step is testing. When this signal is low, it

			means the test step is ended but not go to the next step yet or all test steps are ended.
18	/PA	Output	When the test is enabled, the signal level is high. Every time the PA mode is passed, the /PA signal and COM port High or Low level will change.
19,20	+VEXT	----	It is the external DC voltage input. The input voltage range is between +3V~+26V.
21,22	+24VF1	----	It is the internal DC voltage output. The output voltage is +24V.
23	RESERVED	Input	Reserved pin.
24	/RECALL1	Input	/RECALL1~/RECALL3 signals indicate the read memory code. The input use 3 bits to indicate. The input format is in binary code (/RECALL1 is low bit and /RECALL3 is high bit). 001 means to recall memory 1. 111 means to recall memory 7.
25	/RECALL2	Input	
26	/RECALL3	Input	
27	/E_STOP	Input	It is the external STOP signal input and active when the status is low.
28	/E_START	Input	It is the external START signal input and active when the status is low.
29	/LOCK	Output	It controls valve when using with A190512.
30	RESERVED	Output	Reserved pin.
31	/TOTAL_FAIL	Output	It outputs High when all test results are PASS; otherwise, it will output Low.
32	RESERVED	Output	Reserved pin.
33,34	EXTGND	----	It is the low voltage terminal of input/output signal.
35,36	DGND	----	It is the low voltage terminal for internal voltage output.

Note : The test setting errors are described as follows:

Error Message	Description
TIMEOUT	The communication with LCR METER is timeout.
SAMPLE FAIL	No sampling waveform in IWT / IWT COMPARE / BDV mode.
OUTPUT INVALID	The output voltage is not set.
CHANNEL INVALID	The output channel is not set or wrong.
SCANNER MISSING	The scanner is set but not enabled or not connected.
T. PROBE MISSING	The temperature probe is not connected when the temperature compensation function is set to auto.

TOTAL TIME TOO SHORT	The time setting is too short in DCR / Δ/Y DCR mode.
OUTPUT VOLTAGE LIMITED	The internal output voltage of the analyzer reaches the high limit but the DUT voltage cannot meet the set voltage in IWT / IWT COMPARE / BDV mode.
SAMPLE FAIL (NOT ENOUGH CYCLES)	The sampling resonant cycle is insufficient in IWT mode.
LCR NOT READY	The LCR METER is not connected or L COMBINE is not set to enable.
LCR NOT CONFIGURED	The test parameters were not successfully written in the LCR METER.
AUTO EXPORTING...	It is unable to perform next step when AUTO EXPORT is executed to export data.
DISK NOT EXIST	When the AUTO EXPORT function is on, the USB flash drive is not detected before executing the next test step.

5.2 Example of External Control Circuit

5.2.1 Example of Using Internal Power Supply

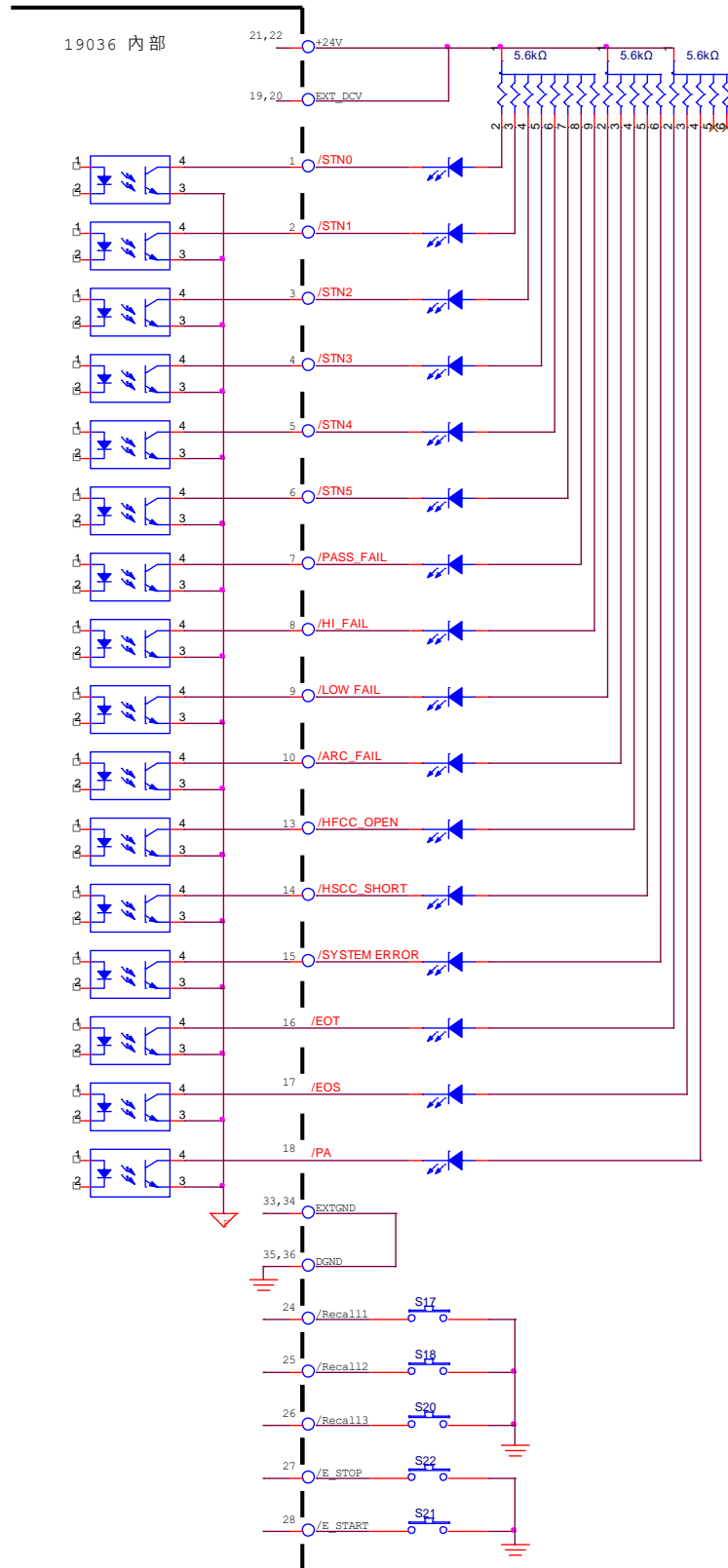

5.2.2 Example of Using External Power Supply

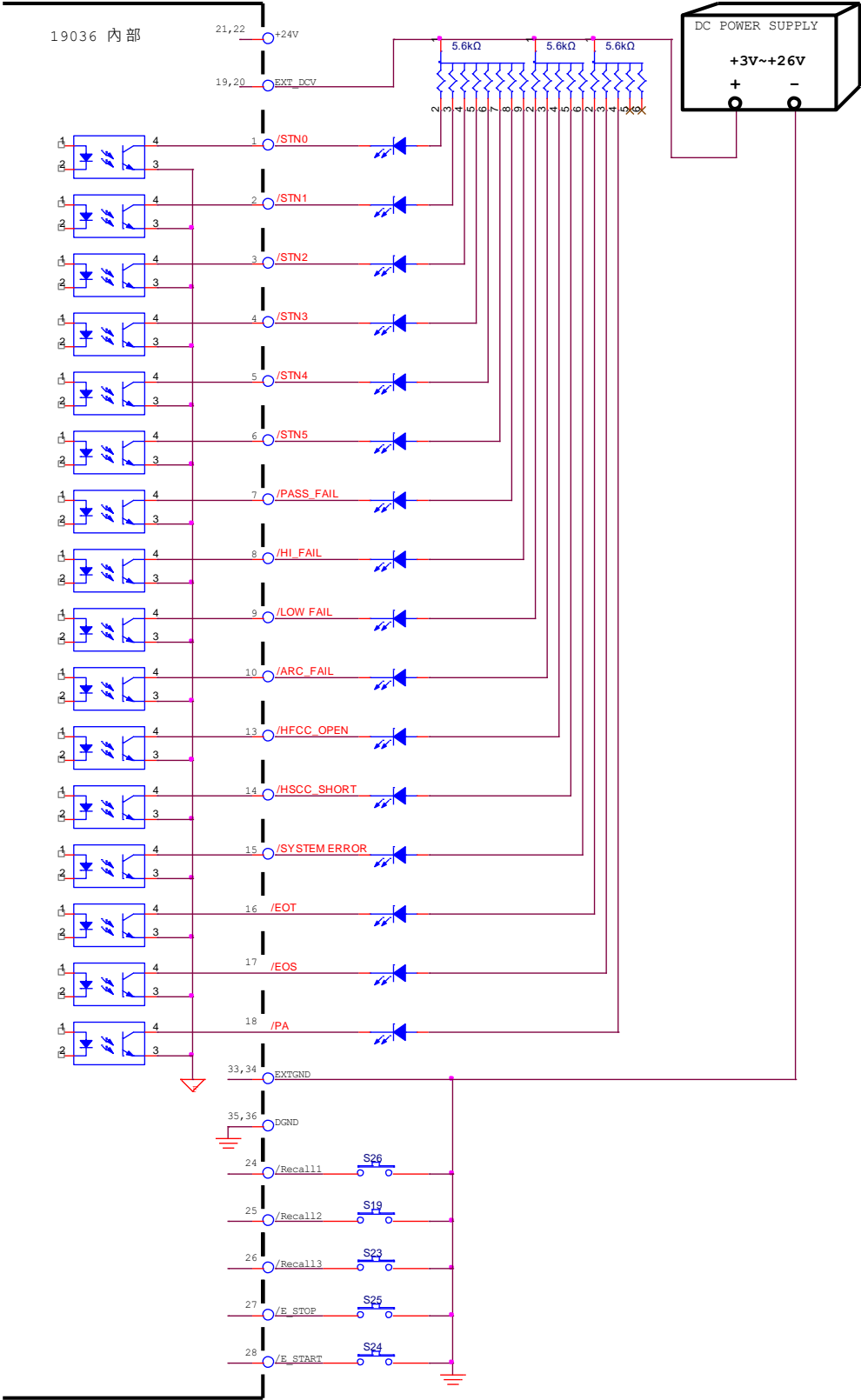

5.3 Timing Diagram

(1) Set TOTAL P/F to OFF

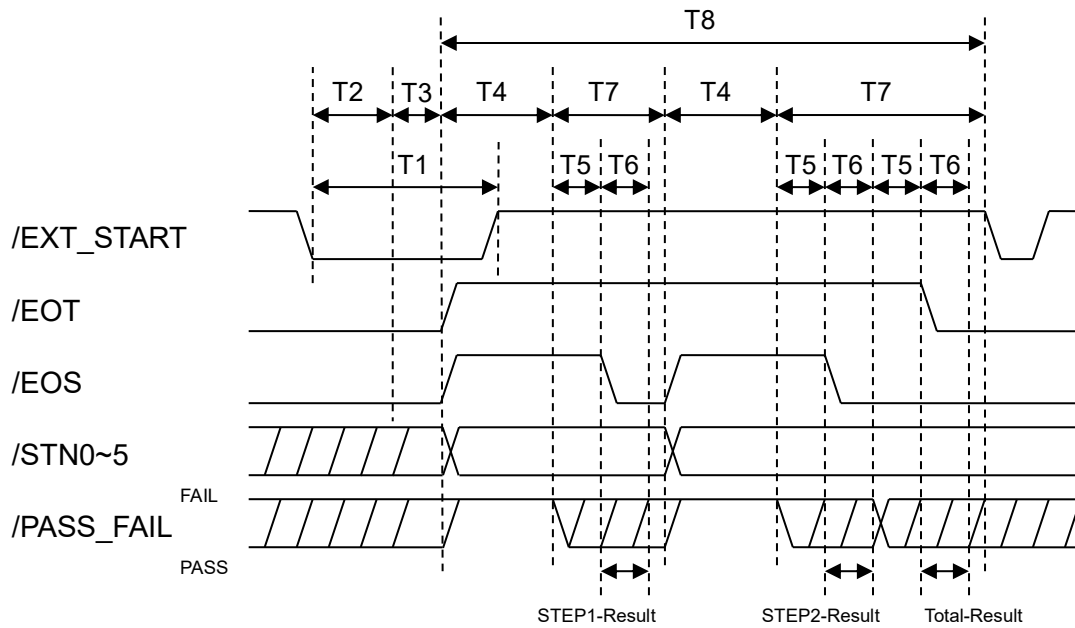

Figure 5-1 Timing Diagram – Example of 2 Test Steps

(2) Set TOTAL P/F to ON

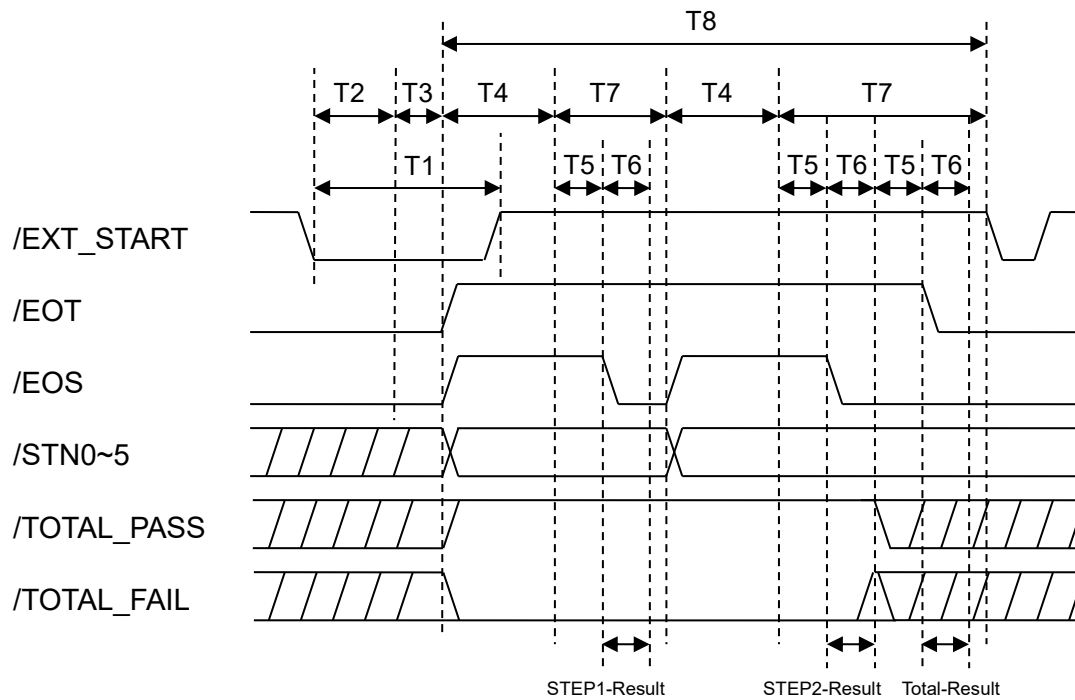

Figure 5-2 Timing Diagram – Example of 2 Test Steps

Timing	Limit	Description
T1	> 20ms	It sets the time required for external trigger signal (/EXT_START) to sustain. It should be more than 20ms.
T2	< 20ms	It sets the time for clear from external trigger signal (/EXT_START) to /EOT signal. It should be less than 20ms.
T3	-	It sets the time for Trigger Delay.
T4	-	It sets the time required for each test step.
T5	> 5ms	The waiting time will be more than 5ms for /PASS_FAIL signal to be stable.
T6	> 5ms	The waiting time will be more than 5ms for EOS Hold time, EOS HOLD time + SUB PASS time or /EOT signals to be stable.
T7	-	The time required for each test step to end.
T8	-	The time required for a test program.

6. Usage of Impulse Winding Test Modes

6.1 Features and Functions

The impulse winding test modes of 19036 Wound Component EST Analyzer has built-in the following commonly used detection methods.

- (1) AREA
- (2) DIFF-AREA
- (3) FLUTTER
- (4) LAPLACIAN
- (5) Δ Peak%
- (6) Delta Resonant Area
- (7) Delta Resonant Frequency

6.2 Introduction to Impulse Test

The "impulse test" uses a suitable test voltage to apply a "non-destructive", high-speed, and low-energy impulse voltage to the winding components, by analyzing/comparing the difference between the equivalent waveform of the DUT and the sample, determining if the DUT is good or bad. The impulse test applied to the winding component is mainly to find out the potential defects on it, such as: layer short circuit, corona discharge or partial discharge, etc. The stray capacitance and inductance of the DUT can also be used to determine the product quality. This state of oscillating attenuation represents the energy loss state of the DUT coil when it is working. When the switch is turned ON, an impulse voltage will apply to the DUT and then use it to detect if the insulation distance inside the DUT coils is sufficient. When the switch is turned OFF, the DUT will resonate with the stray capacitance of its own, and the attenuation state of the self-resonant waveform is used to detect the DUT's quality.

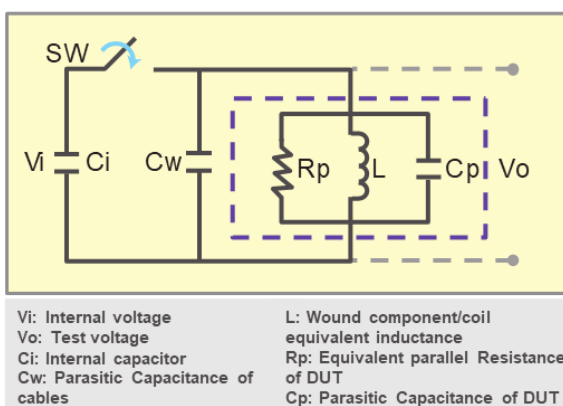

Impulse Winding Test equivalent circuit diagram

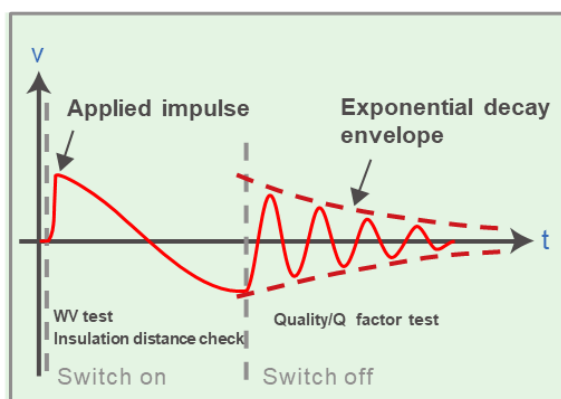

Impulse Winding Test waveform schematic diagram

6.3 Precautions for Setting up Impulse Testing Environment

Since the characteristic of wound component is easy to affect by magnetic field or floating capacity, the environment to conduct the test needs to take the installation of main device and the connection of coil fixture under test into consideration to assure the accuracy of test. The air coils is most sensitive to the environment that needs to pay special attention to its usage and test environment.

Before running initialization and getting the SAMPLE waveform for comparison test, be sure the test environment for coils under test is the same as the initial setting of SAMPLE waveform. In addition, be sure not to use a metal work platform to avoid the errors caused by magnetic effects. If a metal work platform is required, be sure to cover with a layer of non-metallic material pads to prevent affecting the coil characteristic.

Another important parameter for environmental factor is the test cable in use. Be sure to confirm the test cable is the same as the one used for initialization when conducting comparison test especially in length and winding.

6.4 PASS/FAIL Detection

- AREA SIZE

When the switch is turned on, an impulse voltage will apply to the DUT to resonate with the capacitance on the circuit. Use the peak voltage to detect the insulation distance inside the DUT coils. When the insulation distance inside the DUT coils is not enough to withstand the voltage of impulse test, a discharge will occur inside the coils, resulting in a smaller total area of the resonant waveform. When the switch is turned off, the DUT will resonate with the stray capacitance of its own, and its quality will be detected by the attenuation state of the self-resonant waveform. When the DUT quality is worse, the faster the self-resonance waveform attenuates, the total area of the DUT resonant waveform will be smaller than the sample resonance. Thus, area comparison can be used to detect the products with insufficient insulation distance or poor quality.

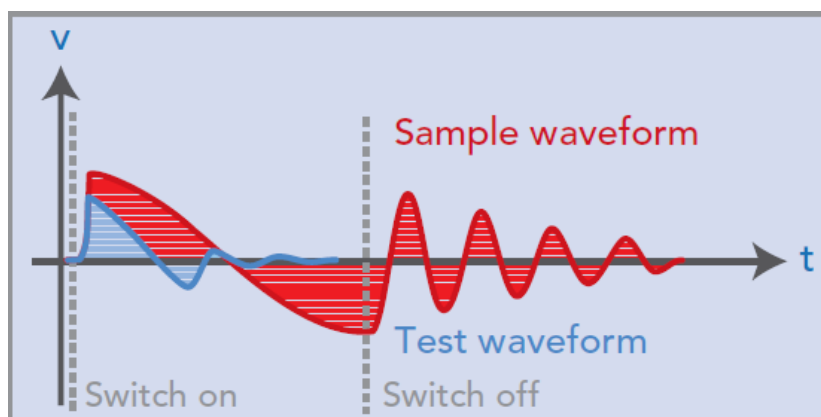

- DIFF-AREA

When the impulse voltage is applied to the DUT, it and the capacitance on the circuit will resonate. If the DUT inductance is different from that of the sample, the resonance frequency will be different as well. At this time, the resonant waveform of the DUT and

the sample will have a non-overlapping area. The area difference comparison will calculate the sum of the non-overlapping areas of resonant waveforms on the DUT and the sample, and compare it with the resonant waveform total area on the sample to display it via a percentage. It is recommended to use with the area comparison (Area), which can filter out the DUT that has a significant difference in inductance from the sample.

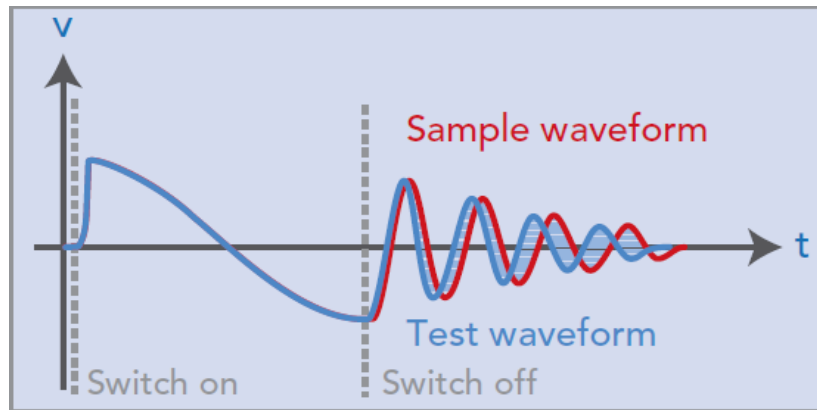

- FLUTTER

When the impulse voltage is applied to the DUT, if the insulation distance inside the coils is insufficient but not reaching insulation breakdown yet, it will occur corona discharge or partial discharge. Corona discharge or partial discharge has little effect on the total area of the resonant waveform because the energy released is very small. Therefore, area comparison is relatively unable to detect the occurrence of corona discharge or partial discharge. The comparison of discharge capacity is to calculate the total length of the resonant waveform using the first order differential calculation. The total length of the resonant waveform is used to detect if corona discharge or partial discharge exists by comparing the length which is generated when there is corona discharge or partial discharge or not.

- LAPLACIAN

When there is corona discharge or partial discharge, the resonant waveform will vibrate and make the originally smooth curve become unsmooth, causing the slew rate of resonant waveform to change drastically. The LAPLACIAN uses the second differential to calculate the slew rate change of the resonant waveform. Therefore, the LAPLACIAN can be used to detect the occurrence of corona discharge or partial discharge, and effectively filter out defective products that have corona discharge or partial discharge.

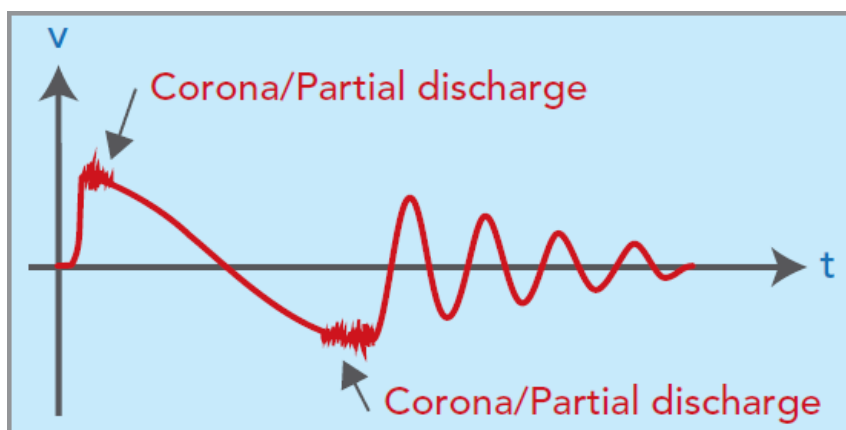

- Peak Ratio**
 The peak ratio has relative relationship with the DUT energy loss state which is related to the quality /Q value of the DUT. When the quality /Q value of the DUT is worse, the resonant waveform attenuation speed of the DUT will be faster, so the peak ratio is lower. Therefore, it can use the peak ratio to detect the change in the DUT quality /Q value during the breakdown voltage test to find out the voltage causing insulation distance on the DUT. The peak ratio is calculated by dividing the third and fifth voltage peaks of the resonant waveform to express in a percentage.

$$\text{Peak Ratio} = \frac{V_5}{V_3} \times 100\%$$

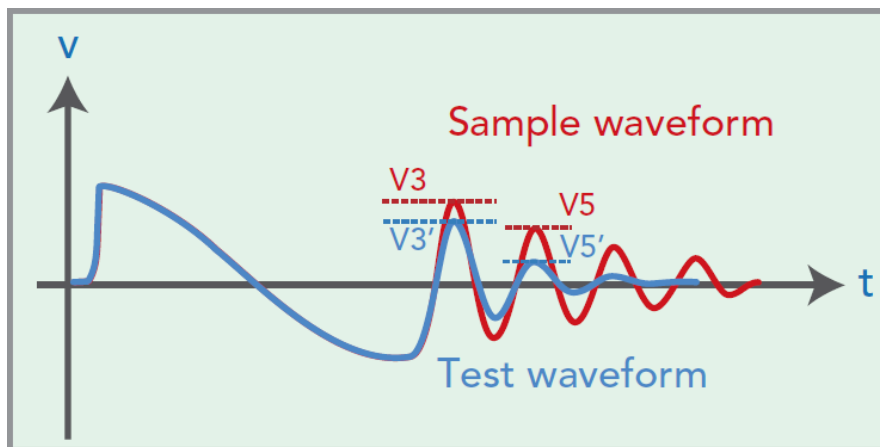

- ΔPeak%**
 The delta peak ratio compares the DUT's resonant waveform peak ratio with that of the samples. When the DUT quality is worse or the attenuation speed of the resonant waveform is faster, the DUT peak ratio will be lower than that of the samples, resulting in the delta peak ratio coming up with a negative result. Therefore, the delta peak ratio can be used to screen out the DUTs that are much different from the sample.

$$\Delta\text{Peak}\% = [\text{Peak Ratio}]_{\text{test}} - [\text{Peak Ratio}]_{\text{sample}}$$

- Delta Resonant Area**
 When the switch is turned off, the attenuation state of the self-resonance waveform that generated by DUT and its stray capacitance is used to detect the quality of DUT. The attenuation state of the self-resonance waveform is affected by the quality of DUT. When the DUT quality is worse, the self-resonance waveform attenuates faster, and the total area of the DUT self-resonance waveform will be smaller than that of the sample. The delta resonant area compares the total area of the self-resonance waveform of the sample and the DUT after the switch is turned off. It can detect the energy attenuation state of the self-resonance waveform more sensitively than the area comparison for product quality detection, screening out the one with poor quality.

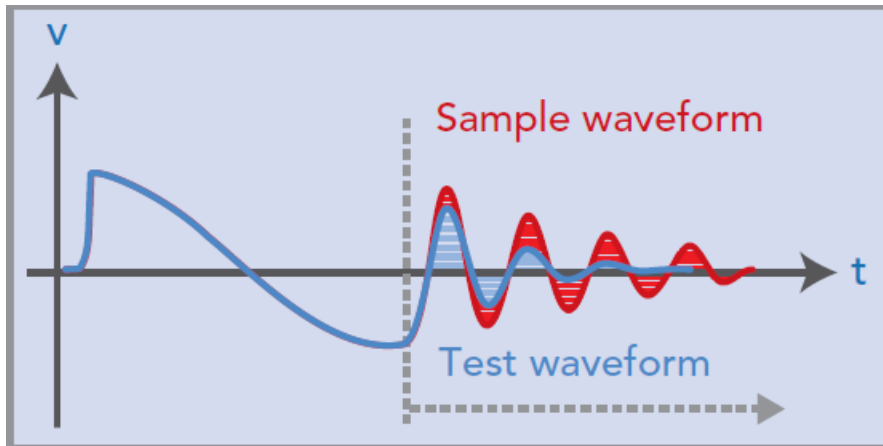

- Delta Resonant Frequency**
 The delta resonant frequency uses the relation between the self-resonant frequency of DUT and the inductance or stray capacity to compare their differences. Because the self-resonant frequency of the DUT is inversely proportional to the inductance or stray capacity, the higher the self-resonant frequency, the lower the inductance or stray capacity, and vice versa. When the self-resonance frequency of the DUT is higher than that of the sample, it means that the inductance or stray capacity of the DUT is lower than that of the sample. When the DUT coils are short-circuited with each other, the inductance or stray capacity will be lower than that of the sample. The delta resonant frequency calculates the percentage of the delta frequency between the DUT and the sample. The delta resonant frequency can detect the difference of inductance or stray capacity between the DUT and the sample, and see if there is a short circuit inside the DUT coils.

$$\Delta\text{Freq} = \frac{\text{Freq}_{\text{test}} - \text{Freq}_{\text{sample}}}{\text{Freq}_{\text{sample}}} \times 100\%$$

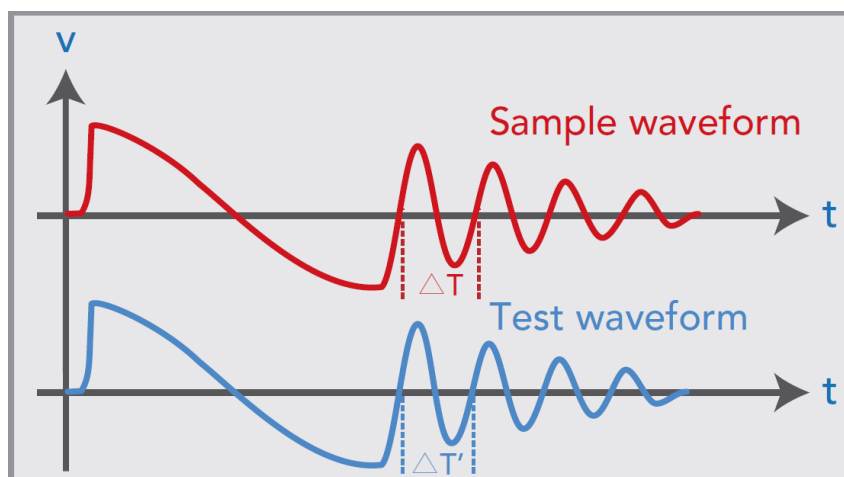

6.5 Waveform Resolution

The transient waveform, generated by the applied impulse, is digitized by a microcomputer and the high speed A/D converter. The memory capacity available for a single transient waveform of the Wound Component EST Analyzer is 8192 bytes (one sample dot per one

byte). In other words, a maximum of 8192 sampling dots can be used to record a transient waveform. The obtained data then is used for display on the LCD, and for OK/NG detection according to the preset criteria.

In case of a coil with a fast transient waveform (a greater frequency), the levels of sampling points are much different from one another, so a slow A/D converter cannot follow the changes. For the Wound Component EST Analyzer, the 5 nano-seconds speedy A/D converter is used in order to digitize the high-speed transient waveform.

Besides the 512 dots resolution in the time axis (X-axis), the recorded resolution of Wound Component EST Analyzer on level vertical axis (Y-axis) is 256 dots. In other words, each dot on time axis (X-axis) has 256 dots resolution to show the amplitude size.

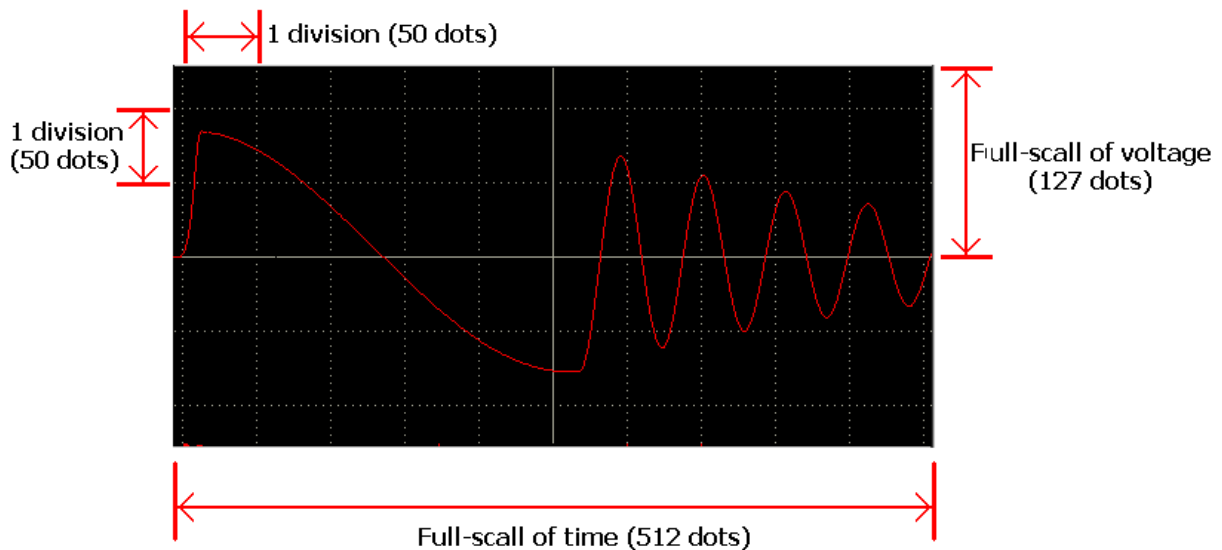

The horizontal and vertical grids appearing on the LED of Wound Component EST Analyzer can give the information about the waveform unit. The resolution of each division is 50 dots and 5 dots resolution for each dot. Multiply the value with the time unit on the upper right corner can get a rough value.

6.6 Setting Sampling Rate

The setting of WIDTH column can be modified for sampling range (which is the adjustment of sampling rate.)

The available setting range is 1 ~ 11.

- 1: The screen displays shorter time range waveform.
- 6: The screen displays general time range waveform.
- 11: The screen display longer time range waveform.

Adjust [WIDTH] setting to change sampling rate. Different [WIDTH] setting parameters draw the characteristic waveform of wound components as the example figures shown below:

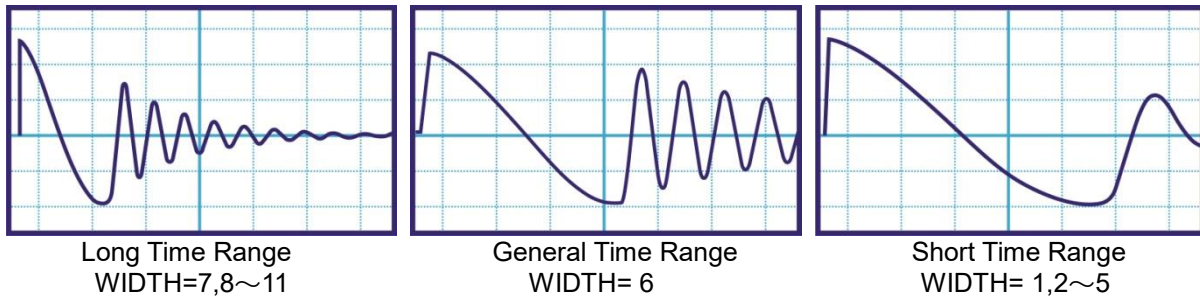

Based on the [WIDTH] in [PROGRAM], press **START** the EST Analyzer will apply impulse and set the sampling rate to display waveform. It can change the setting of WIDTH and press **START** again to re-apply impulse to confirm the most appropriate sampling rate.

Table 6-1 Actual Scanning Rate of WIDTH

WIDTH Range	A/D Sampling Rate	Point Interval	Remarks
1	5 ns	1/1	Highest rate
2	10 ns	1/1	
3	10 ns	1/2	
4	10 ns	1/3	
5	10 ns	1/4	
6	10 ns	1/5	
7	20 ns	1/5	
8	20 ns	1/10	
9	50 ns	1/8	
10	100 ns	1/8	
11	160 ns	1/10	

Note : The higher sampling rate means quick or slight discharge phenomena can be caught.

6.7 Setting Pulse Number

Impulse Winding Test follows the number set here to apply the impulse on the coils of wound component. The available setting range is 1 ~ 32 times. The set impulse number shows in creating SAMPLE waveform and Impulse Winding Test.

Moreover, it can also set Dummy Pulse when setting the impulse number by entering it after the decimal point. The available setting range for Dummy Pulse is 0 ~ 9 and not applying dummy pulse when set to 0.

Ex.) When Applying impulse for 6.3

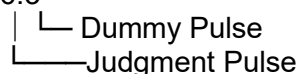

In the example above, 6.3 is to apply 3 times of dummy pulse (no judgment) and then apply 6 times of judgment impulse for final determination. The impulse applied is 9 times in total.

Notice : Residual magnetic field may still exist in Motor coil or Solenoid body after cutting off the power. Performing impulse test under this circumstance may cause the magnetic characteristic initial setting error.

Thus, the results got from applying the 1st impulse and the impulses afterwards are significantly different. Therefore, it is necessary to set proper Dummy Pulse to release the residual magnetic field when testing the instable wound components for good or no good.

6.8 Creating SAMPLE Waveform

It is necessary to draw a waveform of applying impulse on good coil to get the SAMPLE waveform in IWT Mode. The waveform is used to compare and judge the quality of coil under test. Based on the setting of 6.7 *Setting Pulse Number* to obtain the final waveform data of plural impulse and get the SAMPLE waveform.

Different parameter settings may lead to unable obtaining the SAMPLE waveform in some time. In this circumstance, please check if the setting is appropriate. For instance, if the applied impulse voltage was set too high or the wound component is failure.

-  **CAUTION** The reasons for unable obtaining the SAMPLE waveform are:
- (1) The applied voltage is too high and causes the SAMPLE coil under test is having a serious discharge.
 - (2) Proper "WIDTH" sampling rate is not set and causes the cycle of displayed waveform to be very short.
 - (3) The coil under test is easy to produce magnetic saturation phenomenon that made the output unable to reach the set voltage.
 - (4) The inductance of coil under test is too low and out of spec. thus it is unable to output the set voltage. ◦

6.9 Setting Conditions for Judging Good Product

It compares the SAMPLE waveform to judge if the coil under test is good.

- (1) First, determine what condition needs judgment and what doesn't. The setting of LIMIT column is a judgment condition. When LIMIT column sets to OFF, it means do not judge.
- (2) Next, set the columns of BEGIN and END to confirm the start and end of comparison range.
"AREA+", "AREA-" and "DIF-AREA" are 0.1% ~ 99.9%.
"FLUTTER" and "LAPLAC" are the integer between 1~9999.
"ΔPk%+", "ΔPk%-", "ΔR.AREA+", "ΔR.AREA-", "ΔFREQ+", and "ΔFREQ-" are 0.1%~99.9%.

-  **Notice** Once "OFF" is selected for the settings in the above (1), the test procedure does not perform judgment, and "OFF" will show on the screen for inputting judgment condition.

6.10 Impulse Applied and Test Time

It is necessary to set the number for impulse applied to EST Analyzer before test. The number of impulse applied should be proportional to the test time. The interval of each applied impulse is about 50~160ms. The number of pulses applied is proportional to the test time.

6.11 Impulse Applied and Residual Magnetic Field

Residual magnetic field may still exist in Motor coil or Solenoid body after cutting off the power. Performing impulse test under this circumstance may cause the magnetic characteristic initial setting error. Thus, the results got from applying the 1st impulse and the impulses afterwards are significantly different. Therefore, it is necessary to set proper Dummy Pulse to release the residual magnetic field when testing the instable wound components for good or no good. See 6.7 *Setting Pulse Number* for detail setting description.

6.12 Description of Laplacian

When Laplacian bar chart displays, the X-axis (time axis) in the waveform screen is divided into 51 segments and the system will calculate the discharge peak generated in each segment automatically and show them in mapped longitudinal axis bar chart.

There is no unit in the bar chart except the mapped position of discharge volume. The height of bar charge is proportional with the discharge volume so that it can be learned visually.

When Laplacian shows, the horizontal axis resolution is 512 dots which is divided into 51 segments every 10 dots for process in graph. Laplacian bar chart shows the peak level of each segment as the chart standard which is also applied for comparison.

7. Using Remote Interface

7.1 Introduction

The EST Analyzer can be controlled by PC for data transmission through remote interface.

7.2 RS232 Interface

7.2.1 Data Format

- Baud Rate: 9600 / 19200 / 38400 / 57600 / 115200
- Flow Control: NONE / HARDWARE
- Transmission bit: 1 start bit
- 8 data bits
- 1 stop bit

7.2.2 Command Format

The function of RS232 interface is to input the ASCII code composed commands for remote control and setting. The command string length is limited to 8192 characters including End Code. [Command+Parameter] forms an instruction and semicolon “;” is used to connect any two commands with an end code at last. The End Code is one of the following formats:

Command end code

ASCII Code	Hexadecimal Code
LF	0A
CR + LF	0D + 0A

If a command set has multiple entries of return data, use semicolon “;” to connect any two commands with an end code at last. The return data end code of RS232 interface is CR + LF (0D + 0A).

Return data end code

ASCII Code	Hexadecimal Code
CR + LF	0D + 0A

7.2.3 Connector

The RS232 connector of the EST Analyzer is a male 9-pin connector.

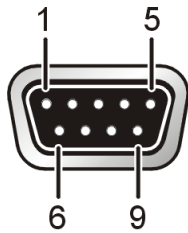

Pin No.		Description
1	*	Unused
2	RxD	Sending data
3	TxD	Receiving data
4	*	Unused
5	GND	Grounding signal
6	*	Unused
7	RTS	Request to Send
8	CTS	Clear to Send
9	*	Unused

7.2.4 Connection

When the flow control sets to NONE:

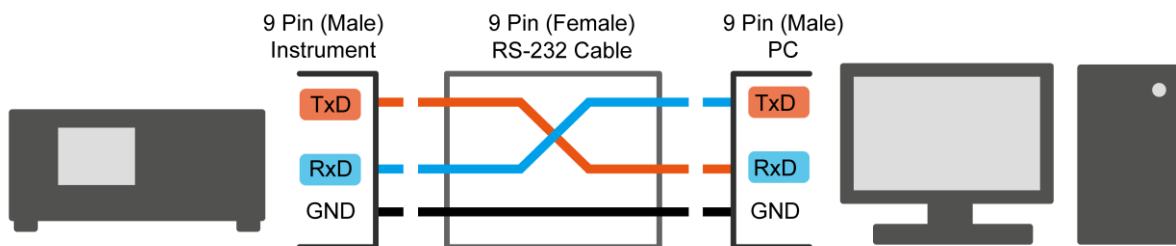

When the flow control sets to HARDWARE:

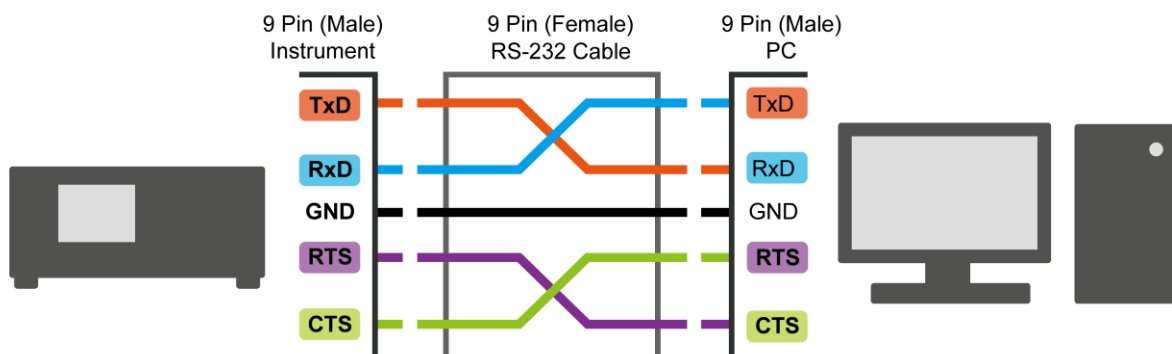

7.3 USB Interface

7.3.1 Specification

USB (B-type): Meet USBTMC

7.3.2 Command Format

The function of USB interface is to input the ASCII code composed commands for remote control and setting. The command string length is limited to 8192 characters including End Code. [Command+Parameter] forms an instruction and semicolon “;” is used to connect any two commands with an end code at last. The End Code is one of the following formats:

Command end code

ASCII Code	Hexadecimal Code
LF	0A
CR + LF	0D + 0A

If a command set has multiple entries of return data, use semicolon “;” to connect any two commands with an end code at last. The return data end code of USB interface is LF (0A).

Return data end code

ASCII Code	Hexadecimal Code
LF	0A

7.4 LAN Interface

7.4.1 Specification

It supports 10M/100M Ethernet.

7.4.2 Command Format

The LAN interface is a 10M/100M Ethernet. Its IP can be set by floating IP which is configured by the server or static IP which is set manually. When the IP address is set and a network cable is used to connect the network, the program uses this IP and 2101 communication port to setup the TCP connection with this device for use. The following sections describe the commands that can control the device remotely.

Command end code

ASCII Code	Hexadecimal Code
LF	0A
CR + LF	0D + 0A

If a command set has multiple entries of return data, use semicolon “;” to connect any two commands with an end code at last. The return data end code of LAN interface is LF (0A).

Return data end code

ASCII Code	Hexadecimal Code
LF	0A

7.5 Commands for Remote Interface

7.5.1 Commands Summary

- **IEEE 488.2 Command**

*CLS
 *ESE < enable value >
 *ESE?
 *ESR?
 *IDN?
 *OPC
 *OPC?
 *PSC < boolean >
 *PSC?
 *RST
 *RCL < register number >
 *SAV < register number >
 *SRE < enable value >
 *SRE?
 *STB?

- **SCPI Command**

The parameter syntax of SCPI command includes:

- (1) Use "< >" to indicate the defined parameter of standard SCPI command.
- (2) Use vertical bar "|" to indicate parameter OR which means one of them can be selected as the parameter.
- (3) Use square brackets "[]" to indicate it can be ignored.
- (4) "<numeric value>" is a decimal data in the following formats:
 - "< NR1 >" integer type, ex. 123.
 - "< NR2 >" decimal type, ex. 3.14.
 - "< NR3 >" index type, ex. +1.234567E+01.
 - "< NRf >" means <NR1>, <NR2> and <NR3> types are all valid.
- (5) "<boolean>" is Boolean program data with value 0 or 1.
- (6) "<string>" is a string data. The format is the data in double quote ("), ex. "ABC".
- (7) "<channel list>" indicates the status of Scanner and Channel. The expression is: (@S1(C1, C2, Cm:Cn,...)) where S1 is scan number, C1 and C2 are respective channel numbers, Cm:Cn means all continuous channels from Cm to Cn. When there are multiple scanners, use comma for connection, for example (@S1(C1, C2, Cm:Cn, ...)),(@S2(C3, C4, Cj:Ck ...)) °
 Ex. (@1(1,3,5:7)),(@2(2:4,6,8)) means to open the channel 1, 3, 5, 6, 7 of Scanner 1 and the channel 2, 3, 4, 6, 8 of Scanner 2 for total 10 channels.
- (8) "< block >" indicates the block data. The format starts from "#0" followed by data, ex. #0ADC.
- (9) When the return data is +9.900000E+37, it means the data is infinitive (INF).

(10) When the return data is +9.910000E+37, it means the data is not a number (NaN) or the setting is OFF.

```

:DISPlay (v2.01)
| :ENABle <boolean> | ON | OFF (v2.01)
| :ENABle? (v2.01)
:MEMory
| :DELete
| | [:NAME] < name >
| | :LOCation < register number >
| :NSTates?
| :STATe
| | :DEFine < name >, < register number >
| | :DEFine? < name >
| | :DEFine:NAME? < register number > (v3.00)
| | :SNUMber? < register number > (v1.01)
MMEMoey
| :DELete < file name > (v3.01)
| :LOAD < file name > (v3.01)
| :STORE < file name > (v3.01)
:TRIGger (v2.01)
| [:SEQUence] (v2.01)
| | :SOURce IMMEDIATE | EXTERNAL | MANUAL (v2.01)
| | :SOURce? (v2.01)
:SYSTem
| :ERRor
| | [:NEXT]?
| :KLOCK <boolean> | ON | OFF (RS232 only)
| :KLOCK?
| :LOCK
| | :OWNer?
| | :RELease (RS232 only)
| | :REQuest? (RS232 only)
| :OPTions (v2.01)
| | :LCOmBine (v2.01)
| | | [:ENABle]? (v2.01)
| | :SCANbox (v2.01)
| | | :CHANnel (v2.01)
| | | | :VALid? (v2.01)
| | | | [:ENABle]? (v2.01)
:TCONtrol
| :AGC
| | [:SOFTware] < boolean > | ON | OFF
| | | [:SOFTware]?
| :DCRBAlance < number value > | OFF
| :DCRBAlance?
| :FAIL
| | :OPERation CONTInue | STOP
| | :OPERation?
| :GFI <boolean> | ON | OFF
| :GFI?
| :IWT (v2.02)
| | : TIME (v2.02)
| | | : INTerval < number value > (v2.02)
| | | : INTerval? (v2.02)
| :LX (v2.00)
| | :ECIRcuit SERIES | PARAllel (v2.00)
| | :ECIRcuit? (v2.00)
| | :FREQuency <number> (v2.00)

```

	:FREQuency?	(v2.00)
	:LEVel <number>	(v2.00)
	:LEVel?	(v2.00)
	:RANGe	(v2.00)
	:AUTO <boolean> ON OFF	(v2.00)
	:AUTO?	(v2.00)
	:LOWer 1 3 5 7 8 10	(v2.00)
	:LOWer?	(v2.00)
	[:UPPer] 1 3 5 7 8 10	(v2.00)
	[:UPPer]?	(v2.00)
	:VALid?	(v2.00)
	:SPEed FAST MEDium SLOW	(v2.00)
	:SPEed?	(v2.00)
	:TIMEout <number>	(v2.00)
	:TIMEout?	(v2.00)
	:RJUDgment <boolean> ON OFF	
	:RJUDgment?	
	:TEMPerature	
	[:COMPensation]	
	[:ENABle] OFF MANual MEASure	
	[:ENABle]?	
	:UNIT C F	
	:UNIT?	
	:TCOefficient <number value>	
	:TCOefficient?	
	:BTEMperature <temperature>	
	:BTEMperature?	
	:ETEMperature <temperature>	
	:ETEMperature?	
	:TIME	
	:PASS <number value>	
	:PASS?	
	:TRIGger	
	[:DELay] <number value> OFF	
	[:DELay]?	
	:AC	
	:FREQuency <number value>	
	:FREQuency?	
	:WRANGe	
	[:AUTO] <boolean> ON OFF	
	[:AUTO]?	
	:VERSion?	
	[:SOURce]	
	:FUNcTion "BREakdown" "GENeral"	(v1.01)
	:FUNcTion?	(v1.01)
	:SAFety	
	:BREakdown	(v1.01)
	:IWT	(v1.01)
	:AREA	(v1.01)
	:LIMit	(v1.01)
	:MINus <number> OFF	(v1.01)
	:MINus?	(v1.01)
	:PLUS <number> OFF	(v1.01)
	:PLUS?	(v1.01)
	:SCOPE	(v1.01)
	:BEGin <number>	(v1.01)
	:BEGin?	(v1.01)
	:END <number>	(v1.01)
	:END?	(v1.01)

:CHANnel		(v1.01)
	[:HIGH] <channel list>	(v1.01)
	[:HIGH]?	(v1.01)
	:LOW <channel list>	(v1.01)
	:LOW?	(v1.01)
:CORRection		(v1.01)
	:LAPLac?	(v3.00)
	:OUTPut <voltage>	(v1.01)
	:OUTPut?	(v1.01)
	:VOLTage?	(v3.01)
	[:WAVeform]	(v1.01)
	:SAMPle	(v1.01)
	[:DATA] GET <waveform>	(v1.01)
	[:DATA]?	(v1.01)
	:LAPLac	(v3.01)
	[:DATA]?	(v3.01)
	:VALid?	(v3.01)
	:SCALe	(v3.00)
	:UP?	(v3.00)
	:DOWN?	(v3.00)
	:VALid?	(v1.01)
	:VOLTage?	(v1.01)
:LAPLac		(v1.01)
	:LIMit <number> OFF	(v1.01)
	:LIMit?	(v1.01)
	:SCOPE	(v1.01)
	:BEGin <number>	(v1.01)
	:BEGin?	(v1.01)
	:END <number>	(v1.01)
	:END?	(v1.01)
[:LEVel]	<start>, <end>, <step>	(v1.01)
[:LEVel]?		(v1.01)
:PULSe	<number>	(v1.01)
:PULSe?		(v1.01)
:RESult		(v1.01)
	:AREPort	(RS232 only)(v3.01)
	:EVENT OFF / STEP FINAl	(RS232 only)(v3.01)
	:EVENT?	(RS232 only)(v3.01)
	:ITEM [item] [,item]	(RS232 only)(v3.01)
	:ITEM?	(RS232 only)(v3.01)
	[:JUDGment]?	(v3.00)
	:METerage<m>?	(v3.00)
	:PNUMber?	(v3.00)
	:STATe?	(v3.00)
	:STEP	(v3.00)
	:ALL	(v3.00)
	:METerage<m>?	(v3.00)
	:NUMBer?	(v3.00)
:WAVeform		(v3.00)
	[:DATA]	(v3.00)
	:LAST?	(v3.00)
	[:WITHstand]?	(v3.00)
	:LAPLac	(v3.00)
	[:DATA]?	(v3.00)
	VALid?	(v3.00)
	:SCALe	(v3.00)
	:UP?	(v3.00)
	:DOWN?	(v3.00)
	:VALid	(v3.00)

		:LAST?	(v3.00)
		[:WITHstand]?	(v3.00)
		:VOLTage	(v3.00)
		:LAST?	(v3.00)
		[:WITHstand]?	(v3.00)
		:WVOLTage?	(v1.01)
		:WIDTh <number>	(v1.01)
		:WIDTh?	(v1.01)
	:FETCh?	[<item>],[<item>]	
	:RESult		
	:ALL		
		:CCMeterage?	(v1.00 Only)
		[:JUDGment]?	
		:METerage<m>?	(v1.01)
		:MMETerage?	(v1.00 Only)
		:MODE?	
		:OMETerage?	(v1.00 Only)
		:RMETerage?	(v1.00 Only)
		:STATe?	(v3.00)
		:TIME	
		[:ELAPsed]	
		:DWELI?	
		:FALL?	
		:RAMP?	
		[:TEST]?	
	:AREPort		(RS232 only)
		[:ENABLE] <boolean> ON OFF	(v3.00)(RS232 only)
		[:ENABLE]?	(v3.00)(RS232 only)
		:ITEM [<item>],[<item>]	(v3.00)(RS232 only)
		:ITEM?	(v3.00)(RS232 only)
	:COMPleted?		
	[:LAST]		
		[:JUDGment] ?	
		:STATe?	(v3.00)
	:STEP<n>		
		[:MAIN] :SUB<n>(Note1)	
		:CCMeterage?	(v1.00 Only)
		:ICOMpare	(v3.01)
		:SCALe	(v3.01)
		:UP?	(v3.01)
		:DOWN?	(v3.01)
		:WINDing<w1>	(v3.01)
		:METerage<m>?	(v3.01)
		:PNUMber?	(v3.01)
		:WAVeform	(v3.01)
		[:DATA]?	(v3.01)
		:LAPLac	(v3.01)
		[:DATA]?	(v3.01)
		VALid?	(v3.01)
		:VALid?	(v3.01)
		:VOLTage?	(v3.01)
		:WINDing<w2>	(v3.01)
		:JSTRing?	(v3.01)
		:METerage<m>?	(v3.01)
		:PNUMber?	(v3.01)
		:STATe?	(v3.01)
	:IWT		(v2.00)
		:PNUMber?	(v2.01)
		:WAVeform	(v2.00)

```

:ICOMpare (v2.00)
| :CHANnel (v2.00)
| | :CLEar (v2.00)
| | :GROup<n> <number>,<number> (v2.00)
| | :GROup<n>? (v2.00)
| :CORRection (v2.00)
| | :FLUTter? (v3.01)
| | :LAPLac? (v3.01)
| | :OUTPut <voltage> (v2.00)
| | :OUTPut? (v2.00)
| | :VOLTage? (v3.01)
| | [:WAVEform] (v2.00)
| | | :SAMPle (v2.00)
| | | [:DATA] GET (v2.00)
| | | [:DATA] GET | <waveform> (v3.02)
| | | [:DATA]? (v3.01)
| | | :LAPLac (v3.01)
| | | | [:DATA]? (v3.01)
| | | | :VALid? (v3.01)
| | | :SCALe (v3.00)
| | | | :UP? (v3.00)
| | | | :DOWN? (v3.00)
| | | :VALid? (v1.01)
| | | :VOLTage? (v1.01)
| | [:LEVel] <number value> (v2.00)
| | [:LEVel]? (v2.00)
| | :WIDTh <number value> (v2.00)
| | :WIDTh? (v2.00)
| | :PULSe <number value> (v2.00)
| | :PULSe? (v2.00)
| :AREA (v2.00)
| | :SCOPE (v2.00)
| | | :BEGin <number value> (v2.00)
| | | :BEGin? (v2.00)
| | | :END <number value> (v2.00)
| | | :END? (v2.00)
| | :LIMit (v2.00)
| | | :PLUS <number value> | OFF (v2.00)
| | | :PLUS? (v2.00)
| | | :MINus <number value> | OFF (v2.00)
| | | :MINus? (v2.00)
| :DARea (v2.00)
| | :LIMit <number value> | OFF (v2.00)
| | :LIMit? (v2.00)
| | :SCOPE (v2.00)
| | | :BEGin <number value> (v2.00)
| | | :BEGin? (v2.00)
| | | :END <number value> (v2.00)
| | | :END? (v2.00)
| :FLUTter (v2.00)
| | :LIMit <number value> | OFF (v2.00)
| | :LIMit? (v2.00)
| | :SCOPE (v2.00)
| | | :BEGin <number value> (v2.00)
| | | :BEGin? (v2.00)
| | | :END <number value> (v2.00)
| | | :END? (v2.00)
| :LAPLac (v2.00)
| | :LIMit <number value> | OFF (v2.00)

```

```

:LiMit? (v2.00)
:SCOPE (v2.00)
| :BEgin <number value> (v2.00)
| :BEgin? (v2.00)
| :END <number value> (v2.00)
| :END? (v2.00)
:IWT
:CHANnel
| [:HIGH] <channel list>
| [:HIGH]?
| :LOW <channel list>
| :LOW?
:CORRection
| :FLUTter? (v3.00)
| :LAPLac? (v3.00)
| :OUTPut <voltage> (v1.01)
| :OUTPut? (v1.01)
| :VOLTage? (v3.01)
| :PRATio? (v3.01)
[:WAVeform]
| :SAMPle
| | [:DATA] GET | <waveform> (v1.01)
| | [:DATA]? (v1.01)
| | :LAPLac (v3.01)
| | | [:DATA]? (v3.01)
| | | :VALid? (v3.01)
| | :SCALe (v3.00)
| | | :UP? (v3.00)
| | | :DOWN? (v3.00)
| | :VALid? (v1.01)
| | :VOLTage? (v1.01)
[:LEVel] <number value>
[:LEVel]?
:WIDTh <number value>
:WIDTh?
:PULSe <number value>
:PULSe?
:AREA
| :SCOPE
| | :BEgin <number value>
| | :BEgin?
| | :END <number value>
| | :END?
| :LiMit
| | :PLUS <number value> | OFF
| | :PLUS?
| | :MINus <number value> | OFF
| | :MINus?
:DARea
| :LiMit <number value> | OFF
| :LiMit?
| :SCOPE
| | :BEgin <number value>
| | :BEgin?
| | :END <number value>
| | :END?
:FLUTter
| :LiMit <number value> | OFF
| :LiMit?

```

```

:SCOPE
| :BEGin <number value>
| :BEGin?
| :END <number value>
| :END?
:LAPLac
| :LIMit <number value> | OFF
| :LIMit?
| :SCOPE
| | :BEGin <number value>
| | :BEGin?
| | :END <number value>
| | :END?
:DPRATio (v3.02)
| :LIMit (v3.02)
| | :PLUS <number value> | OFF (v3.02)
| | :PLUS? (v3.02)
| | :MINus <number value> | OFF (v3.02)
| | :MINus? (v3.02)
:DRArea (v3.02)
| :LIMit (v3.02)
| | :PLUS <number value> | OFF (v3.02)
| | :PLUS? (v3.02)
| | :MINus <number value> | OFF (v3.02)
| | :MINus? (v3.02)
:DFREQuency (v2.02)
| :LIMit (v3.02)
| | :PLUS <number value> | OFF (v3.02)
| | :PLUS? (v3.02)
| | :MINus <number value> | OFF (v3.02)
| | :MINus? (v3.02)
:LX (v2.00)
| :CHANnel (v2.00)
| | [:HIGH] <channel list> (v2.00)
| | [:HIGH]? (v2.00)
| | :LOW <channel list> (v2.00)
| | :LOW? (v2.00)
| :LIMit (v2.00)
| | [:LX] (v2.00)
| | | :HIGH <number> | OFF (v2.00)
| | | :HIGH? (v2.00)
| | | :LOW <number> | OFF (v2.00)
| | | :LOW? (v2.00)
| :Q (v2.00)
| | :HIGH <number> | OFF (v2.00)
| | :HIGH? (v2.00)
| | :LOW <number> | OFF (v2.00)
| | :LOW? (v2.00)
:LBALance (v2.00)
| :CHANnel (v2.00)
| | :CLEar (v2.00)
| | :GROup<n> <number value 1>,<number value 2> (v2.00)
| | :GROup<n>? (v2.00)
| :LIMit (v2.00)
| | :ABS <number> | OFF (v2.00)
| | :ABS? (v2.00)
| | :PERCent <number> | OFF (v2.00)
| | :PERCent? (v2.00)
:TYPE ABS | PERCent (v2.00)

```

```

:TYPE? (v2.00)
:PAUSE
  [:MESSAGE] <string data>
  [:MESSAGE]?
:TIME
  [:TEST] <number value> | KEY
  [:TEST]?
:ECONNECT
  :CHANNEL (v2.00)
  | [:HIGH] <channel list> (v2.00)
  | [:HIGH]? (v2.00)
  | :LOW <channel list> (v2.00)
  | :LOW? (v2.00)
  | [:MESSAGE] <string data> (v2.00)
  | [:MESSAGE]? (v2.00)
:HSCC
  :CHANNEL
  | :CLEAR
  | :GROUP<n> <number value 1>,<number value 2>
  | :GROUP<n>?
:YDELTA
  :CHANNEL
  | :A <channel list>
  | :A?
  | :B <channel list>
  | :B?
  | :C <channel list>
  | :C?
:LIMIT
  :RAB
  | [:HIGH] <number value>
  | [:HIGH]?
  | :LOW <number value> | OFF
  | :LOW?
  :RBC
  | [:HIGH] <number value>
  | [:HIGH]?
  | :LOW <number value> | OFF
  | :LOW?
  :RCA
  | [:HIGH] <number value>
  | [:HIGH]?
  | :LOW <number value> | OFF
  | :LOW?
  :BALANCE
  | [:HIGH] <number value> | OFF
  | [:HIGH]?
:RANGE
  :UPPER <number value>
  :UPPER?
  [:LOWER] <number value>
  [:LOWER]?
  :AUTO <boolean> | ON | OFF
  :AUTO?
:TIME
  | :SWITCH <number value> | OFF (v3.02)
  | :SWITCH? (v3.02)
  | [:TEST] <number value>
  | [:TEST]?

```

***ESE?**

It queries the standard event enable register value of device. The output format is <decimal data> within 0~255.

***ESR?**

It queries the standard event register value of device. The register is cleared to 0 when this command is executed. The output format is <decimal data> within 0~255.

***IDN?**

It reads the basic data of device. The output format is divided by comma into 4 columns, which are manufacturer, device model no., serial no. and firmware version.

***OPC**

It completes the operation.

***OPC?**

It queries the operation for completeness. An ASCII character "1" is output when done.

***PSC 0 | 1**

It clears the power on state. When set to 1, the standard event enable register (ESE), service request enable register (SRE) and Auto Report setting will be cleared during power on. These registers will not be cleared when set to 0.

***PSC?**

It queries the power on state for clearing. The output format is an ASCII character "1" or "0".

***RST**

It resets the device by stopping the test.

***RCL < decimal data >**

It is a read back command.

This command reads back the settings saved in the memory of the device. The parameter is the memory serial no.

***SAV < decimal data >**

It is a save command.

This command saves the settings at present of the device to memory. The parameter is the memory serial no.

***SRE < decimal data >**

It sets the value for service request register. The value is a <decimal data> within 0~255.

***SRE?**

It reads the value of service request enable register. The output format is <decimal data> within 0~255.

***STB?**

It reads the value of status bit register. The output format is <decimal data> within 0~255.

- **SCPI Commands**

:DISPlay:ENABle *<boolean> | ON | OFF*

It sets the measurement display to be enabled or disabled.

:DISPlay:ENABle?

It queries if the measurement display is enabled.

:MEMory:DELeTe[:Name] *<name>*

It deletes the parameter data specified by *<name>* in main memory. *<name>* is a string.

:MEMory:DELeTe: LOCAtion *<register number>*

It deletes the parameter data specified by *<register number >* in main memory. *<register number>* is an integer.

:MEMory:STATe:DEFine *<name>, <register number>*

It sets a name for memory specified by *<register number>*, and *<name>* is a string data.

:MEMory:STATe:DEFine? *<name>*

It queries the memory's *<register number>* specified by *<name>* where *<name>* is string data.

:MEMory:STATe:DEFine:NAME? *<register number>*

It queries the memory's name specified by the *<register number>*.

:MEMory:STATe:SNUMBer? *<register number>*

It queries the STEP number saved in memory specified by *<register number >*, and the return data format is string.

:MEMory:NStates?

It queries the capacity of main memory. The value returned is the maximum of *SAV / *RCL command parameter plus 1.

:MMEMory:DELeTe *<file name>*

It deletes the specified file in the USB flash drive. The *<file name>* does not include the extension and the format is string data. To delete a Chroma.prg file for example, the command is as shown below.

```
MMEM:DEL "chroma"
```

An error message -250, "Mass storage error" will appear if the file does not exist.

:MMEMory:LOAD *<file name>*

It reads the specified file in the USB flash drive. The *<file name>* does not include the extension and the format is string data. To read a Chroma.prg file for example, the command is as shown below.

```
MMEM:LOAD "chroma"
```

An error message -256, "File name not found" will appear if the file does not exist.

:MMEMory:STORE *<file name>*

It saves the specified file in the USB flash drive. The *<file name>* does not include the extension and the format is string data. To save a Chroma.prg file for example, the

command is as shown below.

MMEM:STOR "chroma"

An error message -257,"File name error" will appear if the file with the same name exists.

:TRIGger[:SEQuence]:SOURce IMMEDIATE | EXTERNAL | MANUAL

It sets the interface trigger signal that can be accepted under remote control condition. When IMMEDIATE is set it means only the trigger command from remote control is valid. When EXTERNAL is set it means in addition to the trigger command from remote control is valid, the EXT_TRIGGER from Handler is also valid. This parameter is set automatically at power on. When set to MANUAL, it means besides the trigger command from remote control is valid, the START key on the panel is also valid.

:TRIGger[:SEQuence]:SOURce?

It queries the interface trigger signal that can be accepted under remote control condition.

:SYSTEM:ERROR[:NEXT]?

It reads the messages in Error Queue. See Section 7.6 *Error Messages* for the returned messages.

:SYSTEM:KLOCK <boolean> | ON | OFF

It locks the LOCAL key which only appears in remote mode from switching back to panel control. This command is only applicable to the Remote/Local state of RS232 without affecting the Remote/Local state of USB/LAN.

:SYSTEM:KLOCK?

It queries if the panel control key is locked .

:SYSTEM:LOCK:OWNER?

It queries if the EST Analyzer is in panel control or remote control state.

:SYSTEM: LOCK:RELEASE

It switches back to panel control state.

:SYSTEM:LOCK:REQUEST?

It switches to remote control state. It returns 1 if success or it returns 0.

:SYSTEM:OPTIONS:LCombine[:ENABLE]?

It queries if the inductance measurement mode is enabled.

:SYSTEM:OPTIONS:SCANbox:CHANNEL:VALID?

It queries the valid channel no. Ex. If 1:10,101:116,201:216 is returned, it means the internal channels 1~10, the channels 1~16 of external scan box 1 and channels 1~16 of external scan box 2 are valid.

:SYSTEM:OPTIONS:SCANbox[:ENABLE]?

It queries if the connection of external scan box is enabled. Channel 9 and 10 are invalid if yes.

:SYSTEM:TCONTROL:AGC[:SOFTWARE] <boolean> | ON | OFF

It sets if enabling the software AGC function.

:SYSTem:TCONtrol:AGC[:SOFTware]?

It queries if the software AGC function is enabled.

:SYSTem:TCONtrol:DCRBalance <number value>

It sets the value of DCR Balance in the unit of ohm.

:SYSTem:TCONtrol:DCRBalance?

It queries the value of DCR Balance in the unit of ohm.

:SYSTem:TCONtrol:FAIL:OPERation CONTinue | STOP

It sets the action after the test step is judged as FAIL.

When set to *CONTinue*, it won't stop test after detected FAIL. It will continue the steps afterwards. When set to *STOP*, it will stop test after detected FAIL.

:SYSTem:TCONtrol:FAIL:OPERation?

It queries the setting of AFTER FAIL.

:SYSTem:TCONtrol: GFI <boolean> | ON | OFF

It sets if enabling GFI.

:SYSTem:TCONtrol: GFI?

It queries if GFI is enabled with 0 or 1 returned. (0 means GFI is disabled and 1 means GFI is enabled.)

:SYSTem:TCONtrol:IWT:TIME:INTerval <number>

It sets the interval time for IWT. The range is 0.05s~0.16s and the unit is second.

:SYSTem:TCONtrol:IWT:TIME:INTerval?

It queries the interval time for IWT.

:SYSTem:TCONtrol: LX:ECIRcuit SERIES | PARallel

It sets to series or parallel mode for inductance measurement.

:SYSTem:TCONtrol: LX:ECIRcuit?

It queries the settings of series or parallel mode.

:SYSTem:TCONtrol: LX:FREQuency <number>

It sets the frequency for inductance measurement.

:SYSTem:TCONtrol: LX:FREQuency?

It queries the frequency for inductance measurement.

:SYSTem:TCONtrol: LX:LEVel <number>

It sets the output voltage for inductance measurement.

:SYSTem:TCONtrol: LX:LEVel?

It queries the output voltage for inductance measurement.

:SYSTem:TCONtrol: LX:RANGe:AUTO <boolean> | ON | OFF

It sets if enabling auto range for inductance measurement.

:SYSTem:TCONtrol: LX:RANGe:AUTO ?

It queries if enabled auto range for inductance measurement.

:SYSTem:TCONtrol: LX:RANGe:LOWer 1 | 3 | 5 | 7 | 8 | 10

It sets the range for inductance measurement.

:SYSTem:TCONtrol: LX:RANGe:LOWer?

It queries the range for inductance measurement.

:SYSTem:TCONtrol: LX:RANGe[:UPPer] 1 | 3 | 5 | 7 | 8 | 10

It sets the range for inductance measurement.

:SYSTem:TCONtrol: LX:RANGe[:UPPer]?

It queries the range for inductance measurement.

:SYSTem:TCONtrol: LX:SPEed FAST | MEdium | SLOW

It sets the test speed for inductance measurement.

:SYSTem:TCONtrol: LX:SPEed?

It queries the test speed for inductance measurement.

:SYSTem:TCONtrol: LX:TIMEout <number>

It sets the timeout for inductance measurement.

:SYSTem:TCONtrol: LX:TIMEout?

It queries the timeout for inductance measurement.

:SYSTem:TCONtrol: RJUDgment <boolean > | ON | OFF

It sets if enabling RAMP JUDGMENT.

:SYSTem:TCONtrol: RJUDgment?

It queries if RAMP JUDGMENT is enabled with 0 or 1 returned. (0 means OFF that is disabled and 1 means ON.)

:SYSTem:TCONtrol:TEMPerature[:COMPensation] [:ENABLE] OFF | MAnual | MEASure

It enables the temperature compensation function.

:SYSTem:TCONtrol:TEMPerature[:COMPensation] [:ENABLE]?

It queries if the temperature compensation function is enabled.

:SYSTem:TCONtrol:TEMPerature[:COMPensation]:UNIT C | F

It sets the temperature unit.

:SYSTem:TCONtrol:TEMPerature[:COMPensation]:UNIT?

It queries the temperature unit.

:SYSTem:TCONtrol:TEMPerature[:COMPensation]:TCOefficient <numeric value>

It sets the temperature coefficient with the unit in ppm.

:SYSTem:TCONtrol:TEMPerature[:COMPensation]:TCOefficient?

It queries the temperature coefficient with the unit in ppm.

:SYSTem:TCONtrol:TEMPerature[:COMPensation]:BTEMPerature <numeric value>

It sets the standard site temperature in the unit of °C or °F following the setting of :SYSTem:TCONtrol:TEMPerature[:COMPensation]:UNIT.

:SYSTem:TCONtrol:TEMPerature[:COMPensation]: BTEMPerature?

It queries the standard site temperature in the unit of °C or °F following the setting of :SYSTem:TCONtrol:TEMPerature[:COMPensation]:UNIT.

:SYSTem:TCONtrol:TEMPerature[:COMPensation]:ETEMPerature <numeric value>

It sets the environment temperature in the unit of °C or °F following the setting of :SYSTem:TCONtrol:TEMPerature[:COMPensation]:UNIT. Use this parameter when:SYSTem:TCONtrol:TEMPerature[:COMPensation] [:ENABLE] is set to MANUAl.

:SYSTem:TCONtrol:TEMPerature[:COMPensation]:ETEMPerature?

It queries the environment temperature in the unit of °C or °F following the setting of :SYSTem:TCONtrol:TEMPerature[:COMPensation]:UNIT.

:SYSTem:TCONtrol: TIME:PASS <numeric_value>

It sets the time for PASS HOLD duration. The unit is second.

:SYSTem:TCONtrol: TIME:PASS?

It queries the time for PASS HOLD duration.

:SYSTem:TCONtrol:TRIGger[:DELay] <numeric_value>

It sets the time delayed for trigger. The unit is second.

:SYSTem:TCONtrol: TRIGger[:DELay]?

It queries the time delayed for trigger. The unit is second.

:SYSTem:TCONtrol:AC:FREQuency <numeric value>

It sets the output voltage frequency when under AC withstand voltage test. The setting range is 50Hz or 60Hz.

:SYSTem:TCONtrol:AC:FREQuency?

It queries the output voltage frequency when under AC withstand voltage test.

:SYSTem:TCONtrol:WRANge[:AUTO] <boolean> | ON | OFF

It sets if enabling the withstand voltage auto range function.

:SYSTem:TCONtrol:WRANge[:AUTO]?

It queries if the withstand voltage auto range function is enabled with 0 or 1 returned. (0 means OFF is disabled and 1 means ON.)

:SYSTem:VERSion?

It queries supported SCPI version of this device.

[:SOURce]:FUNction "BREakdown" | "GENeral"

It sets the test mode to be BDV mode or general mode. The input parameter format is string data.

[:SOURce]:FUNction?

It queries the setting value of test mode. The return data is string.

[:SOURce]:SAFety:BREakdown:IWT:AREA:LIMit:MINus <numeric value> |OFF

It sets the LIMIT- value of AREA condition for BDV testing and the range is 0.001~0.999. The LIMIT- setting is disabled when the parameter is set to OFF.

[:SOURce]:SAFety:BR EAkdown:IWT:ARE A:LIMit:MINus?

It queries the LIMIT- setting of AREA condition for BDV testing.

[:SOURce]:SAFety:BR EAkdown:IWT:ARE A:LIMit:PLUS <numeric value> |OFF

It sets the LIMIT+ value of AREA condition for BDV test and the range is 0.001~0.999. The LIMIT+ setting is disabled when the parameter is set to OFF.

[:SOURce]:SAFety:BR EAkdown:IWT:ARE A:LIMit:PLUS?

It queries the LIMIT+ setting of AREA condition for BDV testing.

[:SOURce]:SAFety:BR EAkdown:IWT:ARE A:SCOPE:BE GIn <numeric value>

It sets the BEGIN value of AREA condition for BDV testing. The range is 1~512.

[:SOURce]:SAFety:BR EAkdown:IWT:ARE A:SCOPE:BE GIn?

It queries the BEGIN setting of AREA condition for BDV testing.

[:SOURce]:SAFety:BR EAkdown:IWT:ARE A:SCOPE:EN D <numeric value>

It sets the END value of AREA condition for BDV testing. The range is 1~512.

[:SOURce]:SAFety:BR EAkdown:IWT:ARE A:SCOPE:EN D?

It queries the END setting of AREA condition for BDV testing.

[:SOURce]:SAFety:BR EAkdown:IWT:CHANnel[:HIGH] <channel_list>

[:SOURce]:SAFety:BR EAkdown:IWT:CHANnel[:HIGH] <channel_list>

It sets the high voltage output scan channel for BDV testing.

[:SOURce]:SAFety:BR EAkdown:IWT:CHANnel[:HIGH]?

[:SOURce]:SAFety:BR EAkdown:IWT:CHANnel[:HIGH]?

It queries the high voltage output scan channel for BDV testing.

[:SOURce]:SAFety:BR EAkdown:IWT:CHANnel:LOW <channel_list>

[:SOURce]:SAFety:BR EAkdown:IWT:CHANnel:LOW <channel_list>

It sets the output state of common test scan channel (RTN/LOW) for BDV testing.

[:SOURce]:SAFety:BR EAkdown:IWT:CHANnel:LOW?

[:SOURce]:SAFety:BR EAkdown:IWT:CHANnel:LOW?

It queries the output state of common test scan channel (RTN/LOW) for BDV testing.

[:SOURce]:SAFety:BR EAkdown:IWT:CORRection:LAPLac?

It queries the sampling LAPLAC value during BDV testing. This command only returns correct value when executed right after sampling. If any operation is performed before this command, it may return wrong value because the memory is overwritten.

[:SOURce]:SAFety:BR EAkdown:IWT:CORRection:OUTPut <voltage>

It sets the sampling actual output voltage which is different from the DUT voltage for BDV testing. The range is 0~7000V.

[:SOURce]:SAFety:BR EAkdown:IWT:CORRection:OUTPut?

It queries the sampling actual output voltage for BDV testing.

[:SOURce]:SAFety:BR EAkdown:IWT:CORRection:VOLTag e?

It queries the sampling voltage during BDV testing. This command only returns correct value when executed right after sampling. If any operation is performed before this command, it may return wrong value because the memory is overwritten.

[:SOURce]:SAFety:BR EAkdown:IWT:CORRection[:WAVeform]:SAMPLe[:DATA] <block data> | GET

It sets the sampling waveform data or starts sampling process for BDV testing. When the parameter is set to GET, it means to start sampling process. When the parameter is set to <block data>, it means to set the waveform data. The format of <block data> starts from "#0" followed by 512 dots waveform data and each dot is represented by 3 hexadecimal characters. The range is 000~3FF and the data length is 1538 (2+512x3) characters.

[:SOURce]:SAFety:BR EAkdown:IWT:CORRection[:WAVeform]:SAMPLe[:DATA]?

It queries the sampling waveform data for BDV testing. The return data format starts from "#0" followed by 512 dots waveform data and each dot is represented by 3 hexadecimal characters. The range is 000~3FF and the data length is 1538 (2+512x3) characters.

[:SOURce]:SAFety:BR EAkdown:IWT:CORRection[:WAVeform]:SAMPLe:LAPLac[:DATA]?

It queries the sampling LAPLAC waveform data during BDV testing. The maximum return data is 512 dots of LAPLAC value and each entry is separated by comma(,).

[:SOURce]:SAFety:BR EAkdown:IWT:CORRection[:WAVeform]:SAMPLe:LAPLac:VALid?

It queries if the sampling LAPLAC waveform data exists during BDV testing.

[:SOURce]:SAFety:BR EAkdown:IWT:CORRection[:WAVeform]:SAMPLe:SCALE:UP?

It queries the waveform data scale up ratio for display during BDV testing. Use the following formula to convert the waveform data read by [DATA] command ranged from 0~1023 (000~3FF) to the -128~127 waveform data displayed by the analyzer.

$$\text{Display_Y} = ((\text{DATA} - 512) * \text{Scale_Up}) / \text{Scale_Down}$$

Display_Y: Y-axis data displayed on the instrument screen
 DATA: Data read by DATA? command
 Scale_Up: Data read by SCALE:UP? command
 Scale_Down: Data read by SCALE:DOWN? command

[:SOURce]:SAFety:BR EAkdown:IWT:CORRection[:WAVeform]:SAMPLe:SCALE:DOWN?

It queries the waveform data scale down ratio for display during BDV testing. Use the following formula to convert the waveform data read by [DATA] command ranged from 0~1023 (000~3FF) to the -128~127 waveform data displayed by the analyzer.

$$\text{Display_Y} = ((\text{DATA} - 512) * \text{Scale_Up}) / \text{Scale_Down}$$

Display_Y: Y-axis data displayed on the instrument screen
 DATA: Data read by DATA? command
 Scale_Up: Data read by SCALE:UP? command
 Scale_Down: Data read by SCALE:DOWN? command

[:SOURce]:SAFety:BR EAkdown:IWT:CORRection[:WAVeform]:SAMPLe:VALid?

It queries if the sampling waveform data exists for BDV testing.

[:SOURce]:SAFety:BR EAkdown:IWT:CORRection[:WAVeform]:SAMPLe:VOLTage?

It queries the sampling waveform data for BDV testing. The return data is 512 dots

voltage and each voltage entry is separated by comma (,).

[[:SOURce]:SAFety:BR EAkdown:IWT:LAPLac:LIMit <numeric value> |OFF

It sets the LIMIT of LAPLAC condition for BDV testing. The range is 1~9999. The LIMIT setting is disabled when the parameter is set to OFF.

[[:SOURce]:SAFety:BR EAkdown:IWT:LAPLac:LIMit?

It queries the LIMIT setting of LAPLAC condition for BDV testing.

[[:SOURce]:SAFety:BR EAkdown:IWT:LAPLac:SCOPE:BEgIn <numeric value>

It sets the BEGIN value of LAPLAC condition for BDV testing. The range is 1~512.

[[:SOURce]:SAFety:BR EAkdown:IWT:LAPLac:SCOPE:BEgIn?

It queries the BEGIN setting of LAPLAC condition for BDV testing.

[[:SOURce]:SAFety:BR EAkdown:IWT:LAPLac:SCOPE:END <numeric value>

It sets the END value of LAPLAC condition for BDV testing. The range is 1~512.

[[:SOURce]:SAFety:BR EAkdown:IWT:LAPLac:SCOPE:END?

It queries the END setting of LAPLAC condition for BDV testing.

[[:SOURce]:SAFety:BR EAkdown:IWT[:LEVe] <start>, <end>, <step>

It sets the voltage parameter required for BDV testing. The 1st parameter is start voltage with the range from 100V to 6000V, the 2nd parameter is end voltage with range from 100V to 6000V and the 3rd parameter is voltage rise ratio with the range from 0.01 to 0.2.

[[:SOURce]:SAFety:BR EAkdown:IWT[:LEVe]?

It queries the voltage parameter required for BDV testing.

[[:SOURce]:SAFety:BR EAkdown:IWT:PULSe <numeric value>

It sets the PULSE value for BDV testing. The range is 1.0~32.9.

[[:SOURce]:SAFety:BR EAkdown:IWT:PULSe?

It queries the PULSE value for BDV testing.

[[:SOURce]:SAFety:BR EAkdown:IWT:RESult:AREPort:EVENT OFF | STEP | FINAl

It sets auto report the test status for BDV testing (applicable for RS232 interface only). When set to STEP, each complete step will return a test result. When set to FINAl, it will only return test result when the test is completed. If not setting the return data item, "RUNNING" will return during testing, and "PASS" or "FAIL" will return when the test is done. When return items are set, the return data will use comma to combine them into a data string following the default sequence. When the power on status clear (*PSC) query command is set to 1, reboot the analyzer will clear this setting to OFF.

[[:SOURce]:SAFety:BR EAkdown:IWT:RESult:AREPort:EVENT?

It queries if auto report test status of BDV testing is enabled by returning 1 or 0. (Only applicable to RS232 interface).

[[:SOURce]:SAFety:BR EAkdown:IWT:RESult:AREPort:ITEM [item] [,item]

It sets the auto report test item for BDV testing. <item> is the item name and the format is character (only applicable to RS232 interface). When the power on status clear (*PSC) query command is set to 1, reboot the analyzer will clear this setting. The return itmes available for selection are listed in the table below

No.	Item Name	Return Data	Data Format
1	STEP	Test step	< NR1 >
2	JSTRing	Test result	< string >
3	METerage1	VOLTAGE value	< NR3 >
4	METerage2	AREA value	< NR3 >
5	METerage5	LAPLAC value	< NRf > ^(Note1)
6	PNUMber	Pulse number	< NR2 >
7	WVOLTage	Breakdown voltage	< NR3 >

Note1: The LAPLAC return data format is <NR1>; however, it will return 9.910000E+37 (<NR3>) if this judgment item is not enabled.

If not setting the return data item, "PASS" or "FAIL" will return when the test is done. If JSTRing item is set for return, this column is the test result string data as the table shown below.

Return String	Meaning
"PASS"	The test result is PASS.
"AREA+ FAIL"	The test result is AREA+ FAIL.
"AREA- FAIL"	The test result is AREA- FAIL.
"LAPLAC FAIL"	The test result is LAPLAC FAIL.
"SAMPLE FAIL"	No sampling waveform.
"OUTPUT INVALID"	The output voltage is not set.
"OUTPUT VOLTAGE LIMITED"	The device internal output voltage reaches the upper limit, and the DUT voltage does not meet the set voltage.

[:SOURce]:SAFety:BRBreakdown:IWT:RESult:AREPort:ITEM?

It queries the auto return test time for BDV testing. If none is set, it returns NONE (only applicable to RS232 interface).

[:SOURce]:SAFety:BRBreakdown:IWT:RESult[:JUDGment]?

It queries the judgment result code of BDV testing. The meaning of code is as follows:

Code	HEX	DEC
STANDBY	70	112
ABORT	71	113
SAMPLE FAIL	72	114
OUTPUT INVALID		
OUTPUT VOLTAGE LIMITED		
TESTING	73	115
COMPLETED	74	116
PASS		
AREA+ FAIL	51	81
AREA- FAIL	52	82
LAPLAC FAIL	55	85

[:SOURce]:SAFety:BRBreakdown:IWT:RESult:JSTRing?

It queries the code of judgment result for BDV testing. The meaning of return string is shown in the table below.

Return String	Meaning
"PASS"	The test result is PASS.
"AREA+ FAIL"	The test result is AREA+ FAIL.
"AREA- FAIL"	The test result is AREA- FAIL.
"LAPLAC FAIL"	The test result is LAPLAC FAIL.
"SAMPLE FAIL"	No sampling waveform.
"OUTPUT INVALID"	The output voltage is not set.
"OUTPUT VOLTAGE LIMITED"	The device internal output voltage reaches the upper limit, and the DUT voltage does not meet the set voltage.

[:SOURce]:SAFety:BR EAkdown:IWT:RESult:STATe?

It queries the judgment result code of BDV testing. If there are several results, they will be returned with a plus sign '+' for connection. For instance, if the test result is "AREA+ FAIL" and "LAPLAC FAIL", the return data is 5008+5012. The meaning of code is as follows:

Message	IWT BDV
STANDBY	0
UNCOMPLETED	1
SKIP	2
TESTING	3
ABORT	4
COMPLETED	5
PASS	6
AREA+ FAIL	5008
AREA- FAIL	5009
LAPLAC FAIL	5012
SAMPLE FAIL	5036
OUTPUT INVALID	5037
CHANNEL INVALID	5038
SCANNER MISSING	5039
OUTPUT VOLTAGE LIMITED	5041

[:SOURce]:SAFety:BR EAkdown:IWT:RESult:METerage<m>?

It queries the BDV METerage<m> reading. The range and definition of <m> are listed as follows:

Character	Return Data
METerage1	VOLTAGE value
METerage2	AREA value
METerage5	LAPLAC value

[:SOURce]:SAFety:BR EAkdown:IWT:RESult:PNUMber?

It queries the pulse number sent during IWT BDV testing. When the test is failed, this value indicates the number of pulse that detected the FAIL state.

[:SOURce]:SAFety:BR EAkdown:IWT:RESult:STEP:ALL:METerage<n>?

It queries the METerage<n> reading of each BDV step. Refer to the [:SOURce]:SAFety:BR EAkdown:IWT:RESult:METerage<m>? command for the range and definition of <n>. The return data number is the BDV execution steps number.

[[:SOURce]:SAFety:BRERakdown:IWT:RESult:STEP:NUMBER?

It queries the BDV execution steps number.

[[:SOURce]:SAFety:BRERakdown:IWT:RESult:WAVEform[:DATA]:LAST?

It queries the last waveform data during BDV testing. The return data format starts from "#0" followed by waveform data less than 512 dots. Each dot is represented by 3 hexadecimal characters and the data length is 1538 (2+512x3) characters maximum.

[[:SOURce]:SAFety:BRERakdown:IWT:RESult:WAVEform[:DATA][:WITHstand]?

It queries the waveform data before breakdown during BDV testing. The return data format starts from "#0" followed by waveform data less than 512 dots. Each dot is represented by 3 hexadecimal characters and the data length is 1538 (2+512x3) characters maximum.

[[:SOURce]:SAFety:BRERakdown:IWT:RESult:WAVEform:SCALE:UP?

It queries the waveform data scale up ratio for display during BDV testing. Use the following formula to convert the waveform data read by [DATA] command ranged from 0~1023 (000~3FF) to the -128~127 waveform data displayed by the analyzer.

$$\text{Display_Y} = ((\text{DATA} - 512) * \text{Scale_Up}) / \text{Scale_Down}$$

Display_Y: Y-axis data displayed on the instrument screen
 DATA: Data read by DATA? command
 Scale_Up: Data read by SCALE:UP? command
 Scale_Down: Data read by SCALE:DOWN? command

[[:SOURce]:SAFety:BRERakdown:IWT:RESult:WAVEform:SCALE:DOWN?

It queries the waveform data scale down ratio for display during BDV testing. Use the following formula to convert the waveform data read by [DATA] command ranged from 0~1023 (000~3FF) to the -128~127 waveform data displayed by the analyzer.

$$\text{Display_Y} = ((\text{DATA} - 512) * \text{Scale_Up}) / \text{Scale_Down}$$

Display_Y: Y-axis data displayed on the instrument screen
 DATA: Data read by DATA? command
 Scale_Up: Data read by SCALE:UP? command
 Scale_Down: Data read by SCALE:DOWN? command

[[:SOURce]:SAFety:BRERakdown:IWT:RESult:WAVEform:VALid:LAST?

It queries if the last waveform data is valid during BDV testing.

[[:SOURce]:SAFety:BRERakdown:IWT:RESult:WAVEform:VALid[:WITHstand]?

It queries if the waveform data before breakdown is valid during BDV testing.

[[:SOURce]:SAFety:BRERakdown:IWT:RESult:WAVEform:VOLTage:LAST?

It queries the last voltage waveform data during BDV testing. The return data is up to 512 dots of voltage value. Use an index format of 13 characters to send out each voltage value and separate each entry by comma (.). The data length is 7167 ((13+1)x511+13) characters maximum.

[[:SOURce]:SAFety:BRERakdown:IWT:RESult:WAVEform:VOLTage[:WITHstand]?

It queries the last voltage waveform data during BDV testing. The return data is up to 512 dots of voltage value. Use an index format of 13 characters to send out each voltage value and separate each entry by comma (.). The data length is 7167 ((13+1)x511+13) characters maximum.

[:SOURce]:SAFety:BR EAkdown:IWT:RESult:WAVEform:LAPLac[:DATA]?

It queries the Laplac waveform data during BDV testing. The return data is up to 512 dots Laplac value and each entry is separated by comma (,).

[:SOURce]:SAFety:BR EAkdown:IWT:RESult:WAVEform:LAPLac:VALId?

It queries if the Laplac waveform data is valid during BDV testing.

[:SOURce]:SAFety:BR EAkdown:IWT:RESult:WVOLTage?

It sets the breakdown voltage for BDV testing.

[:SOURce]:SAFety:BR EAkdown:IWT:WIDTh <numeric value>

It sets the WIDTH value for BDV testing. The range is 1~11.

[:SOURce]:SAFety:BR EAkdown:IWT:WIDTh?

It queries the WIDTH value for BDV testing.

[:SOURce]:SAFety:FETCh? [<item>] [, <item>]

It queries the measurement result of EST Analyzer. <item> is string data as listed below:

String	Returned Data
STEP	The present STEP No.
MODE	The present MODE.
RELapsed	The time elapsed for RAMP.
RLEave	The time remained for RAMP.
DELapsed	The time elapsed for DWELL.
DLEave	The time remained for DWELL.
TELapsed	The time elapsed for TEST.
TLEave	The time remained for TEST.
FELapsed	The time elapsed for FALL.
FLEave	The time remained for FALL.
METerage1	The reading of Meterage 1. The meaning is listed in the table below.
METerage2	The reading of Meterage 2. The meaning is listed in the table below.
METerage3	The reading of Meterage 3. The meaning is listed in the table below.
METerage4	The reading of Meterage 4. The meaning is listed in the table below.
METerage5	The reading of Meterage 5. The meaning is listed in the table below.
METerage6	Only valid in IWT Mode, indicating the reading of $\Delta Pk\%$.
METerage7	Only valid in IWT Mode, indicating the reading of R.AREA.
METerage8	Only valid in IWT Mode, indicating the reading of $\Delta FREQ$.

The meaning of METerage1~5 in each MODE:

	METerage1	METerage2	METerage3	METerage4	METerage5
AC	Output	Current	HFCC	Real Current	
DC	Output	Current	HFCC		
IR	Output	Resistance			
DCR	Resistance	Temperature	Real Resistance		
IWT	Output	Area	Dif-Area	Flutter	Laplac
Delta/Y DCR	Rab	Rbc	Rca	Temperature	
IWT COMPARE	Output	Area	Dif-Area	Flutter	Laplac
HSCC	Fail Group				

	Index				
OSC	Output	Capacitance			
PA					
Lx	Lx	Q			
Lx BALANCE	Fail Group Index	Percent	ABS		

The meaning of METerage6~8 in IWT MODE:

	METerage6	METerage7	METerage8		
IWT	$\Delta Pk\%$	$\Delta R.Area$	$\Delta Freq$		

[:SOURce]:SAFety:RESult:ALL[:JUDGment]?

It queries all judgment results. The return format is First Step Result, Second Step Result, ..., Last Step Result. The meaning of Code is listed in the table below:

Mode	AC		DC		IR		DCR	
	HEX	DEC	HEX	DEC	HEX	DEC	HEX	DEC
OUTPUT FAIL	21	33	31	49	42	66		
HIGH FAIL	21	33	31	49	41	65	11	17
LOW FAIL	22	34	32	50	42	66	12	18
ARC FAIL	23	35	33	51				
SHORT FAIL	24	36	34	52	44	68		
OPEN FAIL	22	34	32	50				
REAL HIGH FAIL	2a	42						
AREA FAIL								
DIF-AREA FAIL								
FLUTTER FAIL								
LAPLAC FAIL								
GFI FAIL	24	36	34	52	44	68		

Mode	IWT		Delta/Y DCR		IWT COMPARE		HSCC	
	HEX	DEC	HEX	DEC	HEX	DEC	HEX	DEC
OUTPUT FAIL								
HIGH FAIL			11	17				
LOW FAIL			12	18				
ARC FAIL								
SHORT FAIL								
OPEN FAIL							12	18
REAL HIGH FAIL								
AREA+ FAIL	51	81			51	81		
AREA- FAIL	52	82			52	82		
DIF-AREA FAIL	53	83			53	83		
FLUTTER FAIL	54	84			54	84		
LAPLAC FAIL	55	85			55	85		
GFI FAIL								

Mode	OSC		PA		Lx		Lx BALANCE	
	HEX	DEC	HEX	DEC	HEX	DEC	HEX	DEC
OUTPUT FAIL								
HIGH FAIL					11	17	11	17
LOW FAIL					12	18		
ARC FAIL								
SHORT FAIL	61	97						
OPEN FAIL	62	98						
REAL HIGH FAIL								
AREA FAIL								
DIF-AREA FAIL								
FLUTTER FAIL								
LAPLAC FAIL								
GFI FAIL								

Mode	ALL	
	HEX	DEC
STANDBY UNCOMPLETED	70	112
ABORT	71	113
SAMPLE FAIL OUTPUT INVALID CHANNEL INVALID SCANNER MISSING T. PROBE MISSING	72	114
TESTING	73	115
SKIP COMPLETED PASS	74	116

 **Notice**

Since the DCR Balance Fail is a combined judgment result of several steps instead of a single step, so please use `[:SOURce]:SAFety:RESult:TOTal[:JUDGment]?` command to read the judgment result.

[:SOURce]:SAFety:RESult:ALL:STATe?

It queries the judgment result code of all steps. The return format is First Step Result, Second Step Result, ..., Last Step Result, and each of them is separated by comma (,). If there are several judgments for a single step, the column will return several results using '+' for connection. For instance, if step 1 and step 2 are judged as PASS, and the third step is IWT, the test result is "AREA+ FAIL" and "LAPLAC FAIL", and the return data will be 6,6,608+612. The meaning of code is as follows:

	Mode	AC	DC	IR	OSC	DCR	IWT	HSCC	PA	Delta Y	IWT CMP	Lx	Lx Balance	EXT. CONN
Message	Code	100	200	300	400	500	600	700	800	900	1000	1100	1200	1300
STANDBY	0	0	0	0	0	0	0	0	0	0	0	0	0	0
UNCOMPLETED	1	1	1	1	1	1	1	1	1	1	1	1	1	1
SKIP	2	2	2	2	2	2	2	2	2	2	2	2	2	2
TESTING	3	3	3	3	3	3	3	3	3	3	3	3	3	3
ABORT	4	4	4	4	4	4	4	4	4	4	4	4	4	4
COMPLETED	5	5	5	5	5	5	5	5	5	5	5	5	5	5
PASS	6	6	6	6	6	6	6	6	6	6	6	6	6	6
OUTPUT FAIL	1	101	201	301										

HIGH FAIL	2	102	202	302		502				902		1102		
REAL HIGH FAIL	3	103												
LOW FAIL	4	104	204	304		504				904		1104		
ARC FAIL	5	105	205											
OPEN FAIL	6	106	206			406			706			1106	1206	
SHORT FAIL	7	107	207			407						1107	1207	
AREA+ FAIL	8							608				1008		
AREA- FAIL	9							609				1009		
DIF-AREA FAIL	10							610				1010		
FLUTTER FAIL	11							611				1011		
LAPLAC FAIL	12							612						
DCR BALANCE FAIL	31									931				
GFI FAIL	32	132	232	332										
Lx VALUE INVALID	33											1133	1233	
Q VALUE INVALID	34											1134		
TIMEOUT	35											1135		
SAMPLE FAIL	36							636				1036		
OUTPUT INVALID	37	137	237	337	437			637				1037		
CHANNEL INVALID	38	138	238	338	438	538	638	738		938	1038	1138	1238	1338
SCANNER MISSING	39	139	239	339	439	539	639	739		939	1039	1139	1239	1339
T. PROBE MISSING	40					540				940				
OUTPUT VOLTAGE LIMITED	41						641					1041		
TOTALTIME TOO SHORT	51					551								
HIGH FAIL (RANGE ERROR)	52					502								
HIGH FAIL (TOTAL TIME NOT ENOUGH)	53					502								
SAMPLE FAIL (NOT ENOUGH CYCLES)	54						654							
DELTA Pk%+ FAIL	55						655							
DELTA Pk%- FAIL	56						656							
DELTA R.AREA+ FAIL	57						657							
DELTA R.AREA- FAIL	58						658							
DELTA FREQ+ FAIL	59						659							
DELTA FREQ- FAIL	60						660							

[:SOURCE] : SAFETY : RESULT : ALL : METERAGE < m > ?

It queries the METERAGE<m> reading of all STEPs. The range of m is 1~8. Refer to the explanation of [:SOURCE] : SAFETY : FETCH ? command for the Meterage meaning in each MODE.

[:SOURCE] : SAFETY : RESULT : ALL : MODE ?

It queries the MODE of all STEPs and returns the string data.

AC|DC|IR|OSC|DCR|IWT|HSCC|PA|YDELTA|ICOMPARE|LX|LBALANCE

[:SOURCE] : SAFETY : RESULT : ALL : TIME [: ELAPSED] : DWELL ?

It queries the DWELL of all STEPs.

[:SOURce]:SAFety:RESult:ALL:TIME[:ELAPsed]:FALL?

It queries the voltage fall time of all STEPs.

[:SOURce]:SAFety:RESult:ALL:TIME[:ELAPsed]:RAMP?

It queries the voltage ramp time of all STEPs.

[:SOURce]:SAFety:RESult:ALL:TIME[:ELAPsed][:TEST]?

It queries the test time of all STEPs.

[:SOURce]:SAFety:RESult:AREPort[:ENABLE] <boolean> | ON | OFF

It sets if auto reporting the test results (for RS232 interface only). If no return item is set, "PASS" or "FAIL" string will be returned when the test is done. If a return item is set, the return data will follow the default sequence to link the data in series via comma (,). When the power on status clear (*PSC) query command is set to 1, reboot the analyzer will clear this setting to OFF.

[:SOURce]:SAFety:RESult:AREPort[:ENABLE]?

It queries if the device is auto reporting the test result by returning 1 or 0. (For RS232 interface only)

[:SOURce]:SAFety:RESult:AREPort:ITEM [item] [,item]

It sets the auto reporting test item. <item> is the item name. Refer to [:SOURce]:SAFety:FETCh? command for detailed description. (For RS232 interface only) When the power on status clear (*PSC) query command is set to 1, reboot the analyzer will clear this setting.

[:SOURce]:SAFety:RESult:AREPort:ITEM?

It queries the device auto reporting test item. If none is set, it will return NONE. (For RS232 interface only.)

[:SOURce]:SAFety:RESult:COMPLeted?

It queries if the device has completed all test steps by returning 1 or 0.

[:SOURce]:SAFety:RESult[:LAST][:JUDGment]?

It queries the judgment code of the last executed STEP.

[:SOURce]:SAFety:RESult[:LAST]:STATe?

It queries the judgment result code of last executed step. If there are several judgments for a single step, the column will return several results using '+' for connection. For instance, if the IWT test result is "AREA+ FAIL" and "LAPLAC FAIL", the return data is 608+612. Refer to [:SOURce]:SAFety:RESult:ALL:STATe? command for the detailed meaning of code.

[:SOURce]:SAFety:RESult:STEP<n>[:MAIN]:ICOMpare:SCALE:UP?

[:SOURce]:SAFety:RESult:STEP<n>:SUB<s>:ICOMpare:SCALE:UP?

It queries the waveform data scale up ratio of selected STEP in IWT COMPARE MODE for display. Use the following formula to convert the waveform data read by [DATA] command ranged from 0~1023 (000~3FF) to the -128~127 waveform data displayed by the analyzer.

$$\text{Display_Y} = ((\text{DATA} - 512) * \text{Scale_Up}) / \text{Scale_Down}$$

Display_Y: Y-axis data displayed on the instrument screen

DATA: Data read by DATA? command

Scale_Up: Data read by SCALE:UP? command

Scale_Down: Data read by SCALE:DOWN? command

**[[:SOURce]:SAFety:RESult:STEP<n>[:MAIN]:ICOMpare:SCALE:DOWN?
[:SOURce]:SAFety:RESult:STEP<n>:SUB<s>:ICOMpare:SCALE:DOWN?**

It queries the waveform data scale down ratio of selected STEP in IWT COMPARE MODE for display. Use the following formula to convert the waveform data read by [DATA] command ranged from 0~1023 (000~3FF) to the -128~127 waveform data displayed by the analyzer.

$$\text{Display_Y} = ((\text{DATA} - 512) * \text{Scale_Up}) / \text{Scale_Down}$$

Display_Y: Y-axis data displayed on the instrument screen

DATA: Data read by DATA? command

Scale_Up: Data read by SCALE:UP? command

Scale_Down: Data read by SCALE:DOWN? command

[[:SOURce]:SAFety:RESult:STEP<n>[:MAIN]:ICOMpare:WINDing<w1>:METerage<m>?

[[:SOURce]:SAFety:RESult:STEP<n>:SUB<s>:ICOMpare:WINDing<w1>:METerage<m>?

It queries the METerage<m> reading of <w1> for the selected STEP in IWT COMPARE MODE. <w1> is the group number ranged from 1 to 6. <m> is the Meterage number ranged from 1 to 5. The meaning of each Meterage in IWT COMPARE MODE for Winding1 is listed in the table below.

	METerage1	METerage2	METerage3	METerage4	METerage5
Winding1	Output			Flutter	Laplac
Winding2	Output	Area	DArea	Flutter	Laplac

Note : The METerage2 and METerage3 have no measured data due to lack of comparison.

**[[:SOURce]:SAFety:RESult:STEP<n>[:MAIN]:ICOMpare:WINDing<w1>:PNUMBER?
[:SOURce]:SAFety:RESult:STEP<n>:SUB<s>:ICOMpare:WINDing<w1>:PNUMBER?**

It queries the sent pulse number of <w1> for the selected STEP in IWT COMPARE MODE. <w1> is the group number ranged from 1 to 6. If the test result is FAIL, it means the number of pulse detected FAIL.

**[[:SOURce]:SAFety:RESult:STEP<n>[:MAIN]:ICOMpare:WINDing<w1>:WAVEform[:
DATA]?**

**[[:SOURce]:SAFety:RESult:STEP<n>:SUB<s>:ICOMpare:WINDing<w1>:WAVEform[:
:DATA]?**

It queries the <w1> waveform data of selected STEP in IWT COMPARE MODE. <w1> is the group number ranged from 1 to 6. The return data format starts from "#0" followed by waveform data less than 512 points. Each point is represented by 3 hexadecimal characters, and the data length is 1538 (2+512x3) characters at most.

**[[:SOURce]:SAFety:RESult:STEP<n>[:MAIN]:ICOMpare:WINDing<w1>:WAVEform:L
APLac[:DATA]?**

**[[:SOURce]:SAFety:RESult:STEP<n>:SUB<s>:ICOMpare:WINDing<w1>:WAVEform:
LAPLac[:DATA]?**

It queries the Laplac waveform data of <w1> for the selected STEP in IWT COMPARE MODE. <w1> is the group number ranged from 1 to 6. The return data of Laplac value is 512 points at most. Each Laplac value is separated by comma (,).

[[:SOURce]:SAFety:RESult:STEP<n>[:MAIN]:ICOMpare:WINDing<w1>:WAVeform:LAPLac:VALid?

[[:SOURce]:SAFety:RESult:STEP<n>:SUB<s>:ICOMpare:WINDing<w1>:WAVeform:LAPLac:VALid?

It queries if the Laplac waveform data of <w1> for the selected STEP in IWT COMPARE MODE exists. <w1> is the group number ranged from 1 to 6.

[[:SOURce]:SAFety:RESult:STEP<n>[:MAIN]:ICOMpare:WINDing<w1>:WAVeform:VALid?

[[:SOURce]:SAFety:RESult:STEP<n>:SUB<s>:ICOMpare:WINDing<w1>:WAVeform:VALid?

It queries if the <w1> waveform data of selected STEP in IWT COMPARE MODE exists. <w1> is the group number ranged from 1 to 6.

[[:SOURce]:SAFety:RESult:STEP<n>[:MAIN]:ICOMpare:WINDing<w1>:WAVeform:VOLTage?

[[:SOURce]:SAFety:RESult:STEP<n>:SUB<s>:ICOMpare:WINDing<w1>:WAVeform:VOLTage?

It queries the <w1> waveform data of selected STEP in IWT COMPARE MODE. <w1> is the group number and the return data is a 512 points voltage value. Each voltage value is separated by comma (.). For example, SOURce:SAFety:RESult:STEP1:SUB2:ICOM:WIND3:WAV:VOLT? means to query the 3rd waveform data of STEP 1.2 in IWT COMPARE MODE.

[[:SOURce]:SAFety:RESult:STEP<n>[:MAIN]:ICOMpare:WINDing<w1>:WINDing<w2>:JSTRing?

[[:SOURce]:SAFety:RESult:STEP<n>:SUB<s>:ICOMpare:WINDing<w1>:WINDing<w2>:JSTRing?

It queries the test result string of <w1>-<w2> for the selected STEP in IWT COMPARE MODE. <w1> and <w2> are group numbers ranged from 1 to 6. The return string data are shown in the table below.

Return String	Meaning
"PASS"	The test result is PASS.
"AREA+ FAIL"	The test result is AREA+ FAIL.
"AREA- FAIL"	The test result is AREA- FAIL.
"FLUTTER FAIL"	The test result is FLUTTER FAIL.
"LAPLAC FAIL"	The test result is LAPLAC FAIL.
"SAMPLE FAIL"	No sampling waveform.
"OUTPUT INVALID"	The output voltage is not set.
"OUTPUT VOLTAGE LIMITED"	The device internal output voltage reaches the upper limit, and the DUT voltage does not meet the set voltage.

[[:SOURce]:SAFety:RESult:STEP<n>[:MAIN]:ICOMpare:WINDing<w1>:WINDing<w2>:METerage<m>?

[[:SOURce]:SAFety:RESult:STEP<n>:SUB<s>:ICOMpare:WINDing<w1>:WINDing<w2>:METerage<m>?

It queries the METerage<m> reading of <w1>-<w2> for the selected STEP in IWT COMPARE MODE. <w1> and <w2> are group numbers ranged from 1 to 6. <m> is the Meterage number ranged from 1 to 5. The meaning of each Meterage in IWT COMPARE MODE for Winding2 is listed in the table below.

	METerage1	METerage2	METerage3	METerage4	METerage5
Winding1	Output			Flutter	Laplace
Winding2	Output	Area	DArea	Flutter	Laplace

Note : METerage1, METerage4, and METerage5 are measured data of <w2>.

[:SOURce]:SAFety:RESult:STEP<n>[:MAIN]:ICOMpare:WINDing<w1>:WINDing<w2>:PNUMber?

[:SOURce]:SAFety:RESult:STEP<n>:SUB<s>:ICOMpare:WINDing<w1>:WINDing<w2>:PNUMber?

It queries the sent pulse number of <w2> for the selected STEP in IWT COMPARE MODE. <w1> and <w2> are group numbers ranged from 1 to 6. If the test result is FAIL, it means the number of pulse detected FAIL.

[:SOURce]:SAFety:RESult:STEP<n>[:MAIN]:ICOMpare:WINDing<w1>:WINDing<w2>:STATe?

[:SOURce]:SAFety:RESult:STEP<n>:SUB<s>:ICOMpare:WINDing<w1>:WINDing<w2>:STATe?

It queries the judgment result code of <w1>-<w2> for the selected STEP in IWT COMPARE MODE. If this step has several judgment results, the column will return all of them with plus sign '+' in-between, for example the IWT COMPARE test result is "AREA+ FAIL" and "LAPLAC FAIL", the return data is 1008+1012. Refer to the description of command [:SOURce]:SAFety:RESult:ALL:STATe? for the code meaning.

[:SOURce]:SAFety:RESult:STEP<n>[:MAIN]:IWT:PNUMber?

[:SOURce]:SAFety:RESult:STEP<n>:SUB<s>:IWT:PNUMber?

It queries the pulse number sent by IWT testing for the selected STEP. If the test result is FAIL, the number indicates the pulse that detected FAIL.

[:SOURce]:SAFety:RESult:STEP<n>[:MAIN]:IWT:WAVEform[:DATA]?

[:SOURce]:SAFety:RESult:STEP<n>:SUB<s>:IWT:WAVEform[:DATA]?

It queries the IWT waveform data of selected STEP. The return data format starts from "#0" followed by waveform data less than 512 dots. Each dot is represented by 3 hexadecimal characters and the data length is 1538 (2+512x3) characters maximum.

[:SOURce]:SAFety:RESult:STEP<n>[:MAIN]:IWT:WAVEform:SCALE:UP?

[:SOURce]:SAFety:RESult:STEP<n>:SUB<s>:IWT:WAVEform:SCALE:UP?

It queries the IWT waveform data scale up ratio on display for the selected STEP. Use the following formula to convert the waveform data read by [DATA] command ranged from 0~1023 (000~3FF) to the -128~127 waveform data displayed by the analyzer.

$$\text{Display_Y} = ((\text{DATA} - 512) * \text{Scale_Up}) / \text{Scale_Down}$$

Display_Y: Y-axis data displayed on the instrument screen

DATA: Data read by DATA? command

Scale_Up: Data read by SCALE:UP? command

Scale_Down: Data read by SCALE:DOWN? command

[:SOURce]:SAFety:RESult:STEP<n>[:MAIN]:IWT:WAVEform:SCALE:DOWN?

[:SOURce]:SAFety:RESult:STEP<n>:SUB<s>:IWT:WAVEform:SCALE:DOWN?

It queries the IWT waveform data scale down ratio on display for the selected STEP. Use the following formula to convert the waveform data read by [DATA] command ranged from 0~1023 (000~3FF) to the -128~127 waveform data displayed by the analyzer.

$Display_Y = ((DATA - 512) * Scale_Up) / Scale_Down$
 Display_Y: Y-axis data displayed on the instrument screen
 DATA: Data read by DATA? command
 Scale_Up: Data read by SCALE:UP? command
 Scale_Down: Data read by SCALE:DOWN? command

[:SOURce]:SAFety:RESult:STEP<n>[:MAIN]:IWT:WAVeform:VALid?
[:SOURce]:SAFety:RESult:STEP<n>:SUB<s>:IWT:WAVeform:VALid?
 It queries if the IWT waveform data of selected STEP is valid.

[:SOURce]:SAFety:RESult:STEP<n>[:MAIN]:IWT:WAVeform:VOLTage?
[:SOURce]:SAFety:RESult:STEP<n>:SUB<s>:IWT:WAVeform:VOLTage?
 It queries the IWT waveform data of selected STEP. The returned data is 512 entries of voltage values separated by comma (.). For instance, [:SOURce]:SAFety:RESult:STEP1:SUB2:IWT:WAV:VOLT? means to query the IWT waveform data of STEP 1.2.

[:SOURce]:SAFety:RESult:STEP<n>[:MAIN]:IWT:WAVeform:LAPLac[:DATA]?
[:SOURce]:SAFety:RESult:STEP<n>:SUB<s>:IWT:WAVeform:LAPLac[:DATA]?
 It queries the Laplac waveform data of selected STEP during IWT testing. The return data is 512 dots Laplac value and each Laplac entry is separated by comma (.).

[:SOURce]:SAFety:RESult:STEP<n>[:MAIN]:IWT:WAVeform:LAPLac:VALid?
[:SOURce]:SAFety:RESult:STEP<n>:SUB<s>:IWT:WAVeform:LAPLac:VALid?
 It queries if the Laplac waveform data of selected STEP is valid during IWT testing.

[:SOURce]:SAFety:RESult:STEP<n>[:MAIN]:JUDGment]?
[:SOURce]:SAFety:RESult:STEP<n>:SUB<s>:JUDGment]?
 It queries the judgement result of selected STEP. For instance, [:SOURce]:SAFety:RESult:STEP1:SUB2:JUDGment? means to query the judgment result of STEP 1.2.

[:SOURce]:SAFety:RESult:STEP<n>[:MAIN]:STATe?
[:SOURce]:SAFety:RESult:STEP<n>:SUB<s>:STATe?
 It queries the judgment result code of selected step. If there are several judgments for a single step, the column will return several results using '+' for connection. For instance, if the IWT test result is "AREA+ FAIL" and "LAPLAC FAIL", the return data will be 608+612. Refer to [:SOURce]:SAFety:RESult:ALL:STATe? command for the detailed meaning of code.

[:SOURce]:SAFety:RESult:STEP<n>[:MAIN]:METerage<m>?
[:SOURce]:SAFety:RESult:STEP<n>:SUB<s>:METerage<m>?
 It queries the METerage<m> reading of selected STEP. The range of m is 1~5. Refer to the explanation of [:SOURce]:SAFety:FETCh? command for the Meterage meaning in each MODE.

[:SOURce]:SAFety:RESult:STEP<n>[:MAIN]:TIME[:ELAPsed]:DWELI?
[:SOURce]:SAFety:RESult:STEP<n>:SUB<s>:TIME[:ELAPsed]:DWELI?
 It queries the DWELL time of selected STEP.

[:SOURce]:SAFety:RESult:STEP<n>[:MAIN]:TIME[:ELAPsed]:FALL?
[:SOURce]:SAFety:RESult:STEP<n>:SUB<s>:TIME[:ELAPsed]:FALL?
 It queries the voltage fall time of selected STEP.

[:SOURce]:SAFety:RESult:STEP<n>[:MAIN]:TIME[:ELAPsed]:RAMP?
[:SOURce]:SAFety:RESult:STEP<n>:SUB<s>:TIME[:ELAPsed]:RAMP?
 It queries the voltage ramp time of selected STEP.

[:SOURce]:SAFety:RESult:STEP<n>[:MAIN]:TIME[:ELAPsed][:TEST]?
[:SOURce]:SAFety:RESult:STEP<n>:SUB<s>:TIME[:ELAPsed][:TEST]?
 It queries the test time of selected STEP.

[:SOURce]:SAFety:RESult:TOTal[:JUDGment]?
 It queries the final judgment result. When the return is 0 it indicates there is no test result, -1 indicates FAIL and 1 indicates PASS.

[:SOURce]:SAFety:SNUMber:MAIN?
 It queries the MAIN STEPs already set in the working memory.

[:SOURce]:SAFety:SNUMber[:TOTal]?
 It queries the STEP set in the working memory including the sum of MAIN STEP and SUB STEP.

[:SOURce]:SAFety:STARt[:ONCE]
 It starts the test following the [:SOURce]:FUNction command setting to normal testing or BDV testing.

[:SOURce]:SAFety:STARt:CORRection:OPEN GET | OFF
 When the parameter is set to GET, it gets the correction of OPEN. The main system may output high voltage at the time, and the correction is disabled when the parameter is set to OFF.

[:SOURce]:SAFety:STARt:CORRection:OPEN?
 It queries if OPEN correction is enabled.

[:SOURce]:SAFety:STARt:CORRection:SHORT GET | OFF
 It gets the correction of SHORT when the parameter is set to GET. The main system may output high voltage at the time, and the correction is disabled when the parameter is set to OFF.

[:SOURce]:SAFety:STARt:CORRection:SHORT?
 It queries if SHORT correction is enabled.

[:SOURce]:SAFety:STARt:CORRection:SAMPlE GET
 It executes sample GET in OSC mode. The main system may output high voltage at the time.

[:SOURce]:SAFety:STARt:CORRection:SAMPlE?
 It queries if sample correction is enabled.

[:SOURce]:SAFety:STOP
 It stops the test.

[:SOURce]:SAFety:STATus?
 It queries the status of current device. The returned data is RUNNING or STOPPED.

[:SOURce]:SAFety:STEP<n>[:MAIN]:DELete
[:SOURce]:SAFety:STEP<n>:SUB<s>:DELete
 [:SOURce]:SAFety:STEP<n>[:MAIN]:DELete command will delete the <n> STEPs and

the SUB STEPs underneath, the STEPs following <n> will forward to fill.

[:SOURce]:SAFety:STEP<n>:SUB<s>:DELeTe command will delete the <n>.<s> STEPs and the STEPs following <n>.<s> will forward to fill. Ex:

SOURce:SAFety:STEP2:SUB3:DELeTe means to delete the STEP of 2.3.

[:SOURce]:SAFety:STEP<n>[:MAIN]:MODE?

[:SOURce]:SAFety:STEP<n>:SUB<s>:MODE?

It queries the MODE of selected STEP and returns data of AC, DC, IR, OSC, DCR, IWT, HSCC, PA, YDELta, ICOMpare, LX, LBA lance, and ECONnect.

[:SOURce]:SAFety:STEP<n>[:MAIN]: AC:CHANnel[:HIGH] <channel_list>

[:SOURce]:SAFety:STEP<n>:SUB<s>:AC:CHANnel[:HIGH] <channel_list>

It sets the high voltage output channel status during scan test for the selected STEP.

[:SOURce]:SAFety:STEP<n>[:MAIN]: AC:CHANnel[:HIGH]?

[:SOURce]:SAFety:STEP<n>:SUB<s>:AC:CHANnel[:HIGH]?

It queries the high voltage output channel status during scan test for the selected STEP.

[:SOURce]:SAFety:STEP<n>[:MAIN]: AC:CHANnel:LOW <channel_list>

[:SOURce]:SAFety:STEP<n>:SUB<s>:AC:CHANnel:LOW <channel_list>

It sets the output status of common test channel (RTN/LOW) during scan for the selected STEP.

[:SOURce]:SAFety:STEP<n>[:MAIN]: AC:CHANnel:LOW?

[:SOURce]:SAFety:STEP<n>:SUB<s>:AC:CHANnel:LOW?

It queries the output status of common test channel (RTN/LOW) during scan for the selected STEP.

[:SOURce]:SAFety:STEP<n>[:MAIN]:AC:CORRection[:CURRent]:OPEN[:RANGe][:BEST] <number value>

[:SOURce]:SAFety:STEP<n>:SUB<s>:AC:CORRection[:CURRent]:OPEN[:RANGe][:BEST] <number value>

It sets the open current for the selected STEP. The unit is ampere and the valid range is 0 ~ 0.10A (the valid range is 0~0.12A when the voltage is set to 4kV.) This command will set the open current of all ranges to this value. Please note that the device may clear this open current if the test parameter is changed. It is suggested to set this open current after all test parameters are set.

[:SOURce]:SAFety:STEP<n>[:MAIN]:AC:CORRection[:CURRent]:OPEN[:RANGe][:BEST]?

[:SOURce]:SAFety:STEP<n>:SUB<s>:AC:CORRection[:CURRent]:OPEN[:RANGe][:BEST]?

It queries the open current of minimum current range for the selected STEP. The unit is ampere.

[:SOURce]:SAFety:STEP<n>[:MAIN]:AC:CORRection[:CURRent]:OPEN[:RANGe]:ALL <range 1>,<range 2>,<range 3>

[:SOURce]:SAFety:STEP<n>:SUB<s>:AC:CORRection[:CURRent]:OPEN[:RANGe]:ALL <range 1>,<range 2>,<range 3>

It sets the open current of each range for the selected STEP. The unit is ampere and the valid range is 0 ~ 0.10A (the valid range is 0~0.12A when the voltage is set to 4kV.)

This command requires 2 parameters, the first parameter is the open current of small current range and the second parameter is the open current of large current range.

Please note that the device may clear this open current if the test parameter is changed. It is suggested to set this open current after all test parameters are set.

[[:SOURce]:SAFety:STEP<n>[:MAIN]:AC:CORRection[:CURRent]:OPEN[:RANGe]:ALL?

[[:SOURce]:SAFety:STEP<n>:SUB<s>:AC:CORRection[:CURRent]:OPEN[:RANGe]:ALL?

It queries the open current of selected STEP. The unit is ampere. This query command will return 2 open currents with comma as the separator. The first is the open current of small current range and the second is for large current range.

[[:SOURce]:SAFety:STEP<n>[:MAIN]:AC:CORRection:RCURrent:OPEN[:RANGe]][:BEST] <number value>

[[:SOURce]:SAFety:STEP<n>:SUB<s>:AC:CORRection:RCURrent:OPEN[:RANGe]][:BEST] <number value>

It sets the open real current for the selected STEP. The unit is ampere and the valid range is 0~0.10A (the valid range is 0~0.12A when the voltage is set to 4kV.). This command will set the open real current of all ranges to this value. Please note that the device may clear this open real current if the test parameter is changed. It is suggested to set this open real current after all test parameters are set.

[[:SOURce]:SAFety:STEP<n>[:MAIN]:AC:CORRection:RCURrent:OPEN[:RANGe]][:BEST]?

[[:SOURce]:SAFety:STEP<n>:SUB<s>:AC:CORRection:RCURrent:OPEN[:RANGe]][:BEST]?

It queries the open real current of minimum current range for the selected STEP. The unit is ampere.

[[:SOURce]:SAFety:STEP<n>[:MAIN]:AC:CORRection:RCURrent:OPEN[:RANGe]:ALL <range 1>,<range 2>,<range 3>

[[:SOURce]:SAFety:STEP<n>:SUB<s>:AC:CORRection:RCURrent:OPEN[:RANGe]:ALL <range 1>,<range 2>,<range 3>

It sets the open real current of each range for the selected STEP. The unit is ampere and the valid range is 0 ~ 0.03A. This command requires 2 parameters, the first parameter is the open real current of small current range and the second parameter is the open real current of large current range. Please note that the device may clear this open real current if the test parameter is changed. It is suggested to set this open real current after all test parameters are set.

[[:SOURce]:SAFety:STEP<n>[:MAIN]:AC:CORRection:RCURrent:OPEN[:RANGe]:ALL?

[[:SOURce]:SAFety:STEP<n>:SUB<s>:AC:CORRection:RCURrent:OPEN[:RANGe]:ALL?

It queries the open current of selected STEP. The unit is ampere. This query command will return 2 open currents with comma as the separator. The first is the open current of small current range and the second is for large current range.

[[:SOURce]:SAFety:STEP<n>[:MAIN]:AC:CORRection:HFCC:OPEN[:RANGe]][:BEST] <number value>

[[:SOURce]:SAFety:STEP<n>:SUB<s>:AC:CORRection:HFCC:OPEN[:RANGe]][:BEST] <number value>

It sets the open real HFCC value for the selected STEP. The unit is F and the valid range is 0 ~ 100pF. Please note that the device may clear the value if the test parameter is changed. Thus, it is suggested to set this value after all test parameters are set.

[[:SOURce]:SAFety:STEP<n>[:MAIN]:AC:CORRection:HFCC:OPEN[:RANGe][:BEST]?

[[:SOURce]:SAFety:STEP<n>:SUB<s>:AC:CORRection:HFCC:OPEN[:RANGe][:BEST]?

It queries the open real HFCC value for the selected STEP. The unit is F.

[[:SOURce]:SAFety:STEP<n>[:MAIN]:AC:CORRection:HFCC:OPEN[:RANGe]:ALL <number value>

[[:SOURce]:SAFety:STEP<n>:SUB<s>:AC:CORRection:HFCC:OPEN[:RANGe]:ALL <number value>

It sets the open real HFCC value for the selected STEP. The unit is F and the valid range is 0 ~ 100pF. Please note that the device may clear the value if the test parameter is changed. Thus, it is suggested to set this value after all test parameters are set.

[[:SOURce]:SAFety:STEP<n>[:MAIN]:AC:CORRection:HFCC:OPEN[:RANGe]:ALL?

[[:SOURce]:SAFety:STEP<n>:SUB<s>:AC:CORRection:HFCC:OPEN[:RANGe]:ALL?

It queries the open real HFCC value for the selected STEP. The unit is F.

[[:SOURce]:SAFety:STEP<n>[:MAIN]:AC[:LEVe] <numeric value>

[[:SOURce]:SAFety:STEP<n>:SUB<s>:AC[:LEVe] <numeric value>

It sets the required voltage during AC withstand voltage test for the selected STEP. The unit is volt.

[[:SOURce]:SAFety:STEP<n>[:MAIN]:AC[:LEVe]?

[[:SOURce]:SAFety:STEP<n>:SUB<s>:AC[:LEVe]?

It queries the required voltage during AC withstand voltage test for the selected STEP. The unit is volt.

[[:SOURce]:SAFety:STEP<n>[:MAIN]:AC:LIMit:ARC <numeric value> | OFF

[[:SOURce]:SAFety:STEP<n>:SUB<s>:AC:LIMit:ARC <numeric value> | OFF

It sets the ARC test of the selected STEP. The unit is ampere. The ARC setting is disabled when the parameter is set to OFF

[[:SOURce]:SAFety:STEP<n>[:MAIN]:AC:LIMit:ARC?

[[:SOURce]:SAFety:STEP<n>:SUB<s>:AC:LIMit:ARC?

It queries the ARC test of the selected STEP. The unit is ampere.

[[:SOURce]:SAFety:STEP<n>[:MAIN]:AC:LIMit[:HIGH] <numeric value>

[[:SOURce]:SAFety:STEP<n>:SUB<s>:AC:LIMit[:HIGH] <numeric value>

It sets the high limit of leakage current in AC withstand voltage for the selected STEP. The unit is ampere.

[[:SOURce]:SAFety:STEP<n>[:MAIN]:AC:LIMit[:HIGH]?

[[:SOURce]:SAFety:STEP<n>:SUB<s>:AC:LIMit[:HIGH]?

It queries the high limit of leakage current in AC withstand voltage for the selected STEP. The unit is ampere.

[[:SOURce]:SAFety:STEP<n>[:MAIN]:AC:LIMit:LOW < numeric value > | OFF

[[:SOURce]:SAFety:STEP<n>:SUB<s>:AC:LIMit:LOW <numeric value> | OFF

It sets the low limit of leakage current in AC withstand voltage for the selected STEP. The unit is ampere. The Low limit setting is disabled when the parameter is set to OFF.

[:SOURce]:SAFety:STEP<n>[:MAIN]:AC:LIMit:LOW?

[:SOURce]:SAFety:STEP<n>:SUB<s>:AC:LIMit:LOW?

It queries the low limit of leakage current in AC withstand voltage for the selected STEP. The unit is ampere.

[:SOURce]:SAFety:STEP<n>[:MAIN]:AC:LIMit:REAL <numeric value> | OFF

[:SOURce]:SAFety:STEP<n>:SUB<s>:AC:LIMit:REAL <numeric value> | OFF

It sets the high limit of real leakage current in AC withstand voltage for the selected STEP. The unit is ampere. The Real Current setting is disabled when the parameter is set to OFF.

[:SOURce]:SAFety:STEP<n>[:MAIN]:AC:LIMit:REAL?

[:SOURce]:SAFety:STEP<n>:SUB<s>:AC:LIMit:REAL?

It queries the high limit of real leakage current in AC withstand voltage for the selected STEP. The unit is ampere.

[:SOURce]:SAFety:STEP<n>[:MAIN]:AC:LIMit:OPEN <numeric value>

[:SOURce]:SAFety:STEP<n>:SUB<s>:AC:LIMit:OPEN<numeric value>

It sets the HFCC OPEN value in AC withstand voltage for the selected STEP.

[:SOURce]:SAFety:STEP<n>[:MAIN]:AC:LIMit:OPEN?

[:SOURce]:SAFety:STEP<n>:SUB<s>:AC:LIMit:OPEN?

It queries the HFCC OPEN value in AC withstand voltage for the selected STEP.

[:SOURce]:SAFety:STEP<n>[:MAIN]:AC:LIMit:SHORT <numeric value> | OFF

[:SOURce]:SAFety:STEP<n>:SUB<s>:AC:LIMit:SHORT <numeric value> | OFF

It sets the HFCC SHORT in AC withstand voltage for the selected STEP.

[:SOURce]:SAFety:STEP<n>[:MAIN]:AC:LIMit:SHORT?

[:SOURce]:SAFety:STEP<n>:SUB<s>:AC:LIMit:SHORT?

It queries the HFCC SHORT in AC withstand voltage for the selected STEP.

[:SOURce]:SAFety:STEP<n>[:MAIN]:AC:CSTandard < numeric value >

[:SOURce]:SAFety:STEP<n>:SUB<s>:AC:CSTandard < numeric value >

It sets the capacitance of HFCC in AC withstand voltage for the selected STEP. The unit is F.

[:SOURce]:SAFety:STEP<n>[:MAIN]:AC:CSTandard?

[:SOURce]:SAFety:STEP<n>:SUB<s>:AC:CSTandard?

It queries the capacitance of HFCC in AC withstand voltage for the selected STEP. The unit is F.

[:SOURce]:SAFety:STEP<n>[:MAIN]:AC:TIME:FALL <numeric value> | OFF

[:SOURce]:SAFety:STEP<n>:SUB<s>:AC:TIME:FALL<numeric value> | OFF

It sets the time required for the set voltage to fall to the low voltage for the selected STEP. The unit is second. The Fall Time setting is disabled when the parameter is OFF.

[:SOURce]:SAFety:STEP<n>[:MAIN]:AC:TIME:FALL?

[:SOURce]:SAFety:STEP<n>:SUB<s>:AC:TIME:FALL?

It queries the time required for the set voltage to fall to the low voltage for the selected STEP. The unit is second.

[:SOURce]:SAFety:STEP<n>[:MAIN]:AC:TIME:RAMP <numeric value> | OFF

[:SOURce]:SAFety:STEP<n>:SUB<s>:AC:TIME:RAMP <numeric value> | OFF

It sets the time required to ramp to the voltage set for test for the selected STEP. The unit is second. The Ramp Time setting is disabled when the parameter is set to OFF.

**[[:SOURce]:SAFety:STEP<n>[:MAIN]:AC:TIME:RAMP?
[:SOURce]:SAFety:STEP<n>:SUB<s>:AC:TIME:RAMP?**

It queries the time required to ramp to the voltage set for test for the selected STEP. The unit is second.

**[[:SOURce]:SAFety:STEP<n>[:MAIN]:AC:TIME[:TEST] <numeric value> | CONTinue
[:SOURce]:SAFety:STEP<n>:SUB<s>:AC:TIME[:TEST] <numeric value> |
CONTinue**

It sets the time required for test for the selected STEP. The unit is second. The test runs continuously when the parameter is set to CONTinue.

**[[:SOURce]:SAFety:STEP<n>[:MAIN]:AC:TIME[:TEST]?
[:SOURce]:SAFety:STEP<n>:SUB<s>:AC:TIME[:TEST]?**

It queries the time required for test for the selected STEP. The unit is second.

**[[:SOURce]:SAFety:STEP<n>[:MAIN]:DC:CHANnel[:HIGH] <channel_list>
[:SOURce]:SAFety:STEP<n>:SUB<s>:DC:CHANnel[:HIGH] <channel_list>**

It sets the status of high voltage output channel during scan test for the selected STEP.

**[[:SOURce]:SAFety:STEP<n>[:MAIN]:DC:CHANnel[:HIGH]?
[:SOURce]:SAFety:STEP<n>:SUB<s>:DC:CHANnel[:HIGH]?**

It queries the status of high voltage output channel during scan test for the selected STEP.

**[[:SOURce]:SAFety:STEP<n>[:MAIN]:DC:CHANnel:LOW <channel_list>
[:SOURce]:SAFety:STEP<n>:SUB<s>:DC:CHANnel:LOW <channel_list>**

It sets the output status of common test channel (RTN/LOW) during scan for the selected STEP.

**[[:SOURce]:SAFety:STEP<n>[:MAIN]:DC:CHANnel:LOW?
[:SOURce]:SAFety:STEP<n>:SUB<s>:DC:CHANnel:LOW?**

It queries the output status of common test channel (RTN/LOW) during scan for the selected STEP.

**[[:SOURce]:SAFety:STEP<n>[:MAIN]:DC:CORRection[:CURRent]:OPEN[:RANGe][:
BEST] <number value>
[:SOURce]:SAFety:STEP<n>:SUB<s>:DC:CORRection[:CURRent]:OPEN[:RANGe]
[:BEST] <number value>**

It sets the open current for the selected STEP. The unit is ampere and the valid range is 0~0.02A. This command will set the open current of all ranges to this value. Please note that the device will clear this open current if the test parameter is changed. It is suggested to set this open current after all test parameters are set.

**[[:SOURce]:SAFety:STEP<n>[:MAIN]:DC:CORRection[:CURRent]:OPEN[:RANGe][:
BEST]?
[:SOURce]:SAFety:STEP<n>:SUB<s>:DC:CORRection[:CURRent]:OPEN[:RANGe]
[:BEST]?**

It queries the open current of minimum current range for the selected STEP. The unit is ampere.

[[:SOURce]:SAFety:STEP<n>[:MAIN]:DC:CORRection[:CURRent]:OPEN[:RANGe]:ALL <range 1>,<range 2>,<range 3>

[[:SOURce]:SAFety:STEP<n>:SUB<s>:DC:CORRection[:CURRent]:OPEN[:RANGe]:ALL <range 1>,<range 2>,<range 3>

It sets the open current of each range for the selected STEP. The unit is ampere and the valid range is 0~0.02A. This command requires 3 parameters; the first parameter is the open current of small current range. Please note that the device will clear this open current if the test parameter is changed. It is suggested to set this open current after all test parameters are set.

[[:SOURce]:SAFety:STEP<n>[:MAIN]:DC:CORRection[:CURRent]:OPEN[:RANGe]:ALL?

[[:SOURce]:SAFety:STEP<n>:SUB<s>:DC:CORRection[:CURRent]:OPEN[:RANGe]:ALL?

It queries the open current of selected STEP. The unit is ampere. This query command will return 3 open currents with comma as the separator. The first is the open current of small current range.

[[:SOURce]:SAFety:STEP<n>[:MAIN]:DC:CORRection:HFCC:OPEN[:RANGe][:BEST] <number value>

[[:SOURce]:SAFety:STEP<n>:SUB<s>:DC:CORRection:HFCC:OPEN[:RANGe][:BEST] <number value>

It sets the open real HFCC value for the selected STEP. The unit is F and the valid range is 0~100pF. Please note that the device may clear the value if the test parameter is changed. Thus, it is suggested to set this value after all test parameters are set.

[[:SOURce]:SAFety:STEP<n>[:MAIN]:DC:CORRection:HFCC:OPEN[:RANGe][:BEST]?

[[:SOURce]:SAFety:STEP<n>:SUB<s>:DC:CORRection:HFCC:OPEN[:RANGe][:BEST]?

It queries the open real HFCC value for the selected STEP. The unit is F.

[[:SOURce]:SAFety:STEP<n>[:MAIN]:DC:CORRection:HFCC:OPEN[:RANGe]:ALL <number value>

[[:SOURce]:SAFety:STEP<n>:SUB<s>:DC:CORRection:HFCC:OPEN[:RANGe]:ALL <number value>

It sets the open real HFCC value for the selected STEP. The unit is F and the valid range is 0~100pF. Please note that the device will clear the value if the test parameter is changed. Thus, it is suggested to set this value after all test parameters are set.

[[:SOURce]:SAFety:STEP<n>[:MAIN]:DC:CORRection:HFCC:OPEN[:RANGe]:ALL?

[[:SOURce]:SAFety:STEP<n>:SUB<s>:DC:CORRection:HFCC:OPEN[:RANGe]:ALL?

It queries the open real HFCC value for the selected STEP. The unit is F.

[[:SOURce]:SAFety:STEP<n>[:MAIN]:DC[:LEVel] <numeric value>

[[:SOURce]:SAFety:STEP<n>:SUB<s>:DC[:LEVel] <numeric value>

It sets the voltage required during DC withstand voltage test for the selected STEP. The unit is volt.

[[:SOURce]:SAFety:STEP<n>[:MAIN]:DC[:LEVel]?

[[:SOURce]:SAFety:STEP<n>:SUB<s>:DC[:LEVel]?

It queries the voltage required during DC withstand voltage test for the selected STEP. The unit is volt.

[[:SOURce]:SAFety:STEP<n>[:MAIN]:DC:LIMit:ARC[:LEVel] <numeric value> | OFF

[[:SOURce]:SAFety:STEP<n>:SUB<s>:DC:LIMit:ARC[:LEVel] <numeric value> | OFF

It sets the ARC test value for the selected STEP. The unit is ampere. The ARC setting is disabled when the parameter is set to OFF

[[:SOURce]:SAFety:STEP<n>[:MAIN]:DC:LIMit:ARC?[:LEVel]
[[:SOURce]:SAFety:STEP<n>:SUB<s>:DC:LIMit:ARC?[:LEVel]

It queries the ARC test value for the selected STEP. The unit is ampere.

[[:SOURce]:SAFety:STEP<n>[:MAIN]:DC:LIMit:ARC[:RLEVel] <numeric value> | DEFault

[[:SOURce]:SAFety:STEP<n>:SUB<s>:DC:LIMit:ARC[:RLEVel] <numeric value> | DEFault

It sets the ARC RAMP test value for the selected STEP. The unit is ampere. It is the same as ARC when the parameter is DEFault.

[[:SOURce]:SAFety:STEP<n>[:MAIN]:DC:LIMit:ARC[:RLEVel]?
[[:SOURce]:SAFety:STEP<n>:SUB<s>:DC:LIMit:ARC[:RLEVel]?

It queries the ARC RAMP test value for the selected STEP. The unit is ampere.

[[:SOURce]:SAFety:STEP<n>[:MAIN]:DC:LIMit[:HIGH] <numeric value>
[[:SOURce]:SAFety:STEP<n>:SUB<s>:DC:LIMit[:HIGH] <numeric value>

It sets the high limit of leakage current in DC withstand voltage for the selected STEP. The unit is ampere.

[[:SOURce]:SAFety:STEP<n>[:MAIN]:DC:LIMit[:HIGH]?
[[:SOURce]:SAFety:STEP<n>:SUB<s>:DC:LIMit[:HIGH]?

It queries the high limit of leakage current in DC withstand voltage for the selected STEP. The unit is ampere.

[[:SOURce]:SAFety:STEP<n>[:MAIN]:DC:LIMit:LOW <numeric value> | OFF
[[:SOURce]:SAFety:STEP<n>:SUB<s>:DC:LIMit:LOW <numeric value> | OFF

It sets the low limit of leakage current in DC withstand voltage for the selected STEP. The unit is ampere. The Low limit setting is disabled when the parameter is set to OFF.

[[:SOURce]:SAFety:STEP<n>[:MAIN]:DC:LIMit:LOW?
[[:SOURce]:SAFety:STEP<n>:SUB<s>:DC:LIMit:LOW?

It queries the low limit of leakage current in DC withstand voltage for the selected STEP. The unit is ampere.

[[:SOURce]:SAFety:STEP<n>[:MAIN]:DC:LIMit:OPEN <numeric value>
[[:SOURce]:SAFety:STEP<n>:SUB<s>:DC:LIMit:OPEN <numeric value>

It sets the HFCC OPEN value in DC withstand voltage for the selected STEP.

[[:SOURce]:SAFety:STEP<n>[:MAIN]:DC:LIMit:OPEN?
[[:SOURce]:SAFety:STEP<n>:SUB<s>:DC:LIMit:OPEN?

It queries the HFCC OPEN value in DC withstand voltage for the selected STEP.

[[:SOURce]:SAFety:STEP<n>[:MAIN]:DC:LIMit:SHORT <numeric value> | OFF
[[:SOURce]:SAFety:STEP<n>:SUB<s>:DC:LIMit:SHORT <numeric value> | OFF

It sets the HFCC SHORT in DC withstand voltage for the selected STEP.

[[:SOURce]:SAFety:STEP<n>[:MAIN]:DC:LIMit:SHORT?
[[:SOURce]:SAFety:STEP<n>:SUB<s>:DC:LIMit:SHORT?

It queries the HFCC SHORT in DC withstand voltage for the selected STEP.

[[:SOURce]:SAFety:STEP<n>[:MAIN]:DC:CSTandard < numeric value >
[[:SOURce]:SAFety:STEP<n>:SUB<s>:DC:CSTandard < numeric value >

It sets the capacitance of HFCC in DC withstand voltage for the selected STEP. The unit is F.

[[:SOURce]:SAFety:STEP<n>[:MAIN]:DC:CSTandard?
[[:SOURce]:SAFety:STEP<n>:SUB<s>:DC:CSTandard?

It queries the capacitance of HFCC in DC withstand voltage for the selected STEP. The unit is F.

[[:SOURce]:SAFety:STEP<n>[:MAIN]:DC:TIME:DWELI <numeric value> | OFF
[[:SOURce]:SAFety:STEP<n>:SUB<s>:DC:TIME:DWELI <numeric value> | OFF

It sets the time required for DWELL for the selected STEP. The unit is second. The Dwell Time setting is disabled when the parameter is set to OFF.

[[:SOURce]:SAFety:STEP<n>[:MAIN]:DC:TIME:DWELI?
[[:SOURce]:SAFety:STEP<n>:SUB<s>:DC:TIME:DWELI?

It queries the time required for DWELL for the selected STEP. The unit is second.

[[:SOURce]:SAFety:STEP<n>[:MAIN]:DC:TIME:FALL <numeric value> | OFF
[[:SOURce]:SAFety:STEP<n>:SUB<s>:DC:TIME:FALL <numeric value> | OFF

It sets the time required for the set voltage to fall to the low voltage for the selected STEP. The unit is second. The Fall Time setting is disabled when the parameter is OFF.

[[:SOURce]:SAFety:STEP<n>[:MAIN]:DC:TIME:FALL?
[[:SOURce]:SAFety:STEP<n>:SUB<s>:DC:TIME:FALL?

It queries the time required for the set voltage to fall to the low voltage for the selected STEP. The unit is second.

[[:SOURce]:SAFety:STEP<n>[:MAIN]:DC:TIME:RAMP <numeric value> | OFF
[[:SOURce]:SAFety:STEP<n>:SUB<s>:DC:TIME:RAMP <numeric value> | OFF

It sets the time required to ramp to the voltage set for test for the selected STEP. The unit is second. The Ramp Time setting is disabled when the parameter is set to OFF.

[[:SOURce]:SAFety:STEP<n>[:MAIN]:DC:TIME:RAMP?
[[:SOURce]:SAFety:STEP<n>:SUB<s>:DC:TIME:RAMP?

It queries the time required to ramp to the voltage set for test for the selected STEP. The unit is second.

[[:SOURce]:SAFety:STEP<n>[:MAIN]:DC:TIME[:TEST] <numeric value> | CONTInue
[[:SOURce]:SAFety:STEP<n>:SUB<s>:DC:TIME[:TEST] <numeric value> |
CONTInue

It sets the time required for test for the selected STEP. The unit is second. The test runs continuously when the parameter is set to CONTInue.

[[:SOURce]:SAFety:STEP<n>[:MAIN]:DC:TIME[:TEST]?
[[:SOURce]:SAFety:STEP<n>:SUB<s>:DC:TIME[:TEST]?

It queries the time required for test for the selected STEP. The unit is second.

**[[:SOURce]:SAFety:STEP<n>[:MAIN]:IR:CHANnel[:HIGH] <channel_list>
[:SOURce]:SAFety:STEP<n>:SUB<s>:IR:CHANnel[:HIGH] <channel_list>**

It sets the status of high voltage output channel during scan test for the selected STEP.

**[[:SOURce]:SAFety:STEP<n>[:MAIN]:IR:CHANnel[:HIGH]?
[:SOURce]:SAFety:STEP<n>:SUB<s>:IR:CHANnel[:HIGH]?**

It queries the status of high voltage output channel during scan test for the selected STEP.

**[[:SOURce]:SAFety:STEP<n>[:MAIN]:IR:CHANnel:LOW <channel_list>
[:SOURce]:SAFety:STEP<n>:SUB<s>:IR:CHANnel:LOW <channel_list>**

It sets the output status of common test channel (RTN/LOW) during scan for the selected STEP.

**[[:SOURce]:SAFety:STEP<n>[:MAIN]:IR:CHANnel:LOW?
[:SOURce]:SAFety:STEP<n>:SUB<s>:IR:CHANnel:LOW?**

It queries the output status of common test channel (RTN/LOW) during scan for the selected STEP.

**[[:SOURce]:SAFety:STEP<n>[:MAIN]:IR:CORRection:CURRent:OPEN[:RANGe][:B
EST] <number value>
[:SOURce]:SAFety:STEP<n>:SUB<s>:IR:CORRection:CURRent:OPEN[:RANGe][:B
EST] <number value>**

It sets the open current for the selected STEP. The unit is ampere and the valid range is 0~0.01A. This command will set the open current of all ranges to this value. Please note that the device may clear this open current if the test parameter is changed. It is suggested to set this open current after all test parameters are set.

**[[:SOURce]:SAFety:STEP<n>[:MAIN]:IR:CORRection:CURRent:OPEN[:RANGe][:B
EST]?
[:SOURce]:SAFety:STEP<n>:SUB<s>:IR:CORRection:CURRent:OPEN[:RANGe][:B
EST]?**

It queries the open current of minimum current range for the selected STEP. The unit is ampere.

**[[:SOURce]:SAFety:STEP<n>[:MAIN]:IR:CORRection:CURRent:OPEN[:RANGe]:AL
L <range 1>,<range 2>,<range 3>,<range 4>,<range 5>,<range 6>,<range 7>
[:SOURce]:SAFety:STEP<n>:SUB<s>:IR:CORRection:CURRent:OPEN[:RANGe]:A
LL <range 1>,<range 2>,<range 3>,<range 4>,<range 5>,<range 6>,<range 7>**

It sets the open current of each range for the selected STEP. The unit is ampere and the valid range is 0~0.01A. This command requires 7 parameters; the first parameter is the open current of minimum current range. Please note that the device may clear this open current if the test parameter is changed. It is suggested to set this open current after all test parameters are set.

**[[:SOURce]:SAFety:STEP<n>[:MAIN]:IR:CORRection:CURRent:OPEN[:RANGe]:AL
L?
[:SOURce]:SAFety:STEP<n>:SUB<s>:IR:CORRection:CURRent:OPEN[:RANGe]:A
LL?**

It queries the open current of selected STEP. The unit is ampere. This query command will return 7 open currents with comma as the separator. The first is the open current of minimum current range.

[[:SOURce]:SAFety:STEP<n>[:MAIN]:IR[:LEVel] <numeric value>
[[:SOURce]:SAFety:STEP<n>:SUB<s>:IR[:LEVel] <numeric value>

It sets the voltage required for insulation resistance test for the selected STEP. The unit is volt.

[[:SOURce]:SAFety:STEP<n>[:MAIN]:IR[:LEVel]?
[[:SOURce]:SAFety:STEP<n>:SUB<s>:IR[:LEVel]?

It queries the voltage required for insulation resistance test for the selected STEP. The unit is volt.

[[:SOURce]:SAFety:STEP<n>[:MAIN]:IR:LIMit:HIGH <numeric value> | OFF
[[:SOURce]:SAFety:STEP<n>:SUB<s>:IR:LIMit:HIGH <numeric value> | OFF

It sets the high limit of insulation resistance for the selected STEP. The unit is ohm. The high limit setting is disabled when the parameter is set to OFF.

[[:SOURce]:SAFety:STEP<n>[:MAIN]:IR:LIMit:HIGH?
[[:SOURce]:SAFety:STEP<n>:SUB<s>:IR:LIMit:HIGH?

It queries the high limit of insulation resistance for the selected STEP. The unit is ohm.

[[:SOURce]:SAFety:STEP<n>[:MAIN]:IR:LIMit[:LOW] <numeric value>
[[:SOURce]:SAFety:STEP<n>:SUB<s>:IR:LIMit[:LOW] <numeric value>

It sets the low limit of insulation resistance for the selected STEP. The unit is ohm.

[[:SOURce]:SAFety:STEP<n>[:MAIN]:IR:LIMit[:LOW]?
[[:SOURce]:SAFety:STEP<n>:SUB<s>:IR:LIMit[:LOW]?

It queries the low limit of insulation resistance for the selected STEP. The unit is ohm.

[[:SOURce]:SAFety:STEP<n>[:MAIN]:IR:RANGe:UPPer <numeric value>
[[:SOURce]:SAFety:STEP<n>:SUB<s>:IR:RANGe:UPPer <numeric value>

It sets the current range for test for the selected STEP. The unit is ampere. The set current range should be larger than the input current.

[[:SOURce]:SAFety:STEP<n>[:MAIN]:IR:RANGe:UPPer?
[[:SOURce]:SAFety:STEP<n>:SUB<s>:IR:RANGe:UPPer?

It queries the current range for test for the selected STEP. The unit is ampere.

[[:SOURce]:SAFety:STEP<n>[:MAIN]:IR:RANGe[:LOWer] <numeric value>
[[:SOURce]:SAFety:STEP<n>:SUB<s>:IR:RANGe[:LOWer] <numeric value>

It sets the current range for test for the selected STEP. The unit is ampere. The set current range should be smaller than the input current.

[[:SOURce]:SAFety:STEP<n>[:MAIN]:IR:RANGe[:LOWer]?
[[:SOURce]:SAFety:STEP<n>:SUB<s>:IR:RANGe[:LOWer]?

It queries the current range of test for the selected STEP. The unit is ampere.

[[:SOURce]:SAFety:STEP<n>[:MAIN]:IR:RANGe:AUTO <boolean> | ON | OFF
[[:SOURce]:SAFety:STEP<n>:SUB<s>:IR:RANGe:AUTO <boolean> | ON | OFF

It sets the current range for test to auto for the selected STEP.

[[:SOURce]:SAFety:STEP<n>[:MAIN]:IR:RANGe:AUTO?
[[:SOURce]:SAFety:STEP<n>:SUB<s>:IR:RANGe:AUTO?

It queries if the current range for test is set to auto for the selected STEP.

[[:SOURce]:SAFety:STEP<n>[:MAIN]:IR:TIME:DWELI <numeric value> | OFF
[[:SOURce]:SAFety:STEP<n>:SUB<s>:IR:TIME:DWELI <numeric value> | OFF
 It sets the time required for DWELL for the selected STEP. The unit is second. The Dwell Time setting is disabled when the parameter is set to OFF.

[[:SOURce]:SAFety:STEP<n>[:MAIN]:IR:TIME:DWELI?
[[:SOURce]:SAFety:STEP<n>:SUB<s>:IR:TIME:DWELI?
 It queries the time required for DWELL for the selected STEP. The unit is second.

[[:SOURce]:SAFety:STEP<n>[:MAIN]:IR:TIME:FALL <numeric value> | OFF
[[:SOURce]:SAFety:STEP<n>:SUB<s>:IR:TIME:FALL <numeric value> | OFF
 It sets the time required for the set voltage to fall to the low voltage for the selected STEP. The unit is second. The FALL TIME setting is disabled when the parameter is OFF.

[[:SOURce]:SAFety:STEP<n>[:MAIN]:IR:TIME:FALL?
[[:SOURce]:SAFety:STEP<n>:SUB<s>:IR:TIME:FALL?
 It queries the time required for the set voltage to fall to the low voltage for the selected STEP. The unit is second.

[[:SOURce]:SAFety:STEP<n>[:MAIN]:IR:TIME:RAMP <numeric value> | OFF
[[:SOURce]:SAFety:STEP<n>:SUB<s>:IR:TIME:RAMP <numeric value> | OFF
 It sets the time required to ramp to the voltage set for test for the selected STEP. The unit is second. The RAMP TIME setting is disabled when the parameter is set to OFF.

[[:SOURce]:SAFety:STEP<n>[:MAIN]:IR:TIME:RAMP?
[[:SOURce]:SAFety:STEP<n>:SUB<s>:IR:TIME:RAMP?
 It queries the time required to ramp to the voltage set for test for the selected STEP. The unit is second.

[[:SOURce]:SAFety:STEP<n>[:MAIN]:IR:TIME[:TEST] <numeric value> |
CONTInue
[[:SOURce]:SAFety:STEP<n>:SUB<s>:IR:TIME[:TEST] <numeric value> |
CONTInue
 It sets the time required for test for the selected STEP. The unit is second. The test runs continuously when the parameter is set to CONTInue.

[[:SOURce]:SAFety:STEP<n>[:MAIN]:IR:TIME[:TEST]?
[[:SOURce]:SAFety:STEP<n>:SUB<s>:IR:TIME[:TEST]?
 It queries the time required for test for the selected STEP. The unit is second.

[[:SOURce]:SAFety:STEP<n>[:MAIN]:DCR:CHANnel[:HIGH] <channel_list>
[[:SOURce]:SAFety:STEP<n>:SUB<s>:DCR:CHANnel[:HIGH] <channel_list>
 It sets the status of high voltage output channel during scan test for the selected STEP.

[[:SOURce]:SAFety:STEP<n>[:MAIN]:DCR:CHANnel[:HIGH]?
[[:SOURce]:SAFety:STEP<n>:SUB<s>:DCR:CHANnel[:HIGH]?
 It queries the status of high voltage output channel during scan test for the selected STEP.

[[:SOURce]:SAFety:STEP<n>[:MAIN]:DCR:CHANnel:LOW <channel_list>
[[:SOURce]:SAFety:STEP<n>:SUB<s>:DCR:CHANnel:LOW <channel_list>
 It sets the output status of common test channel (RTN/LOW) during scan for the selected STEP.

**[[:SOURce]:SAFety:STEP<n>[:MAIN]:DCR:CHANnel:LOW?
[:SOURce]:SAFety:STEP<n>:SUB<s>:DCR:CHANnel:LOW?**

It queries the output status of common test channel (RTN/LOW) during scan for the selected STEP.

**[[:SOURce]:SAFety:STEP<n>[:MAIN]:DCR:CORRection[:RESistance]:SHORT[:RANGe][:BEST] <number value>
[:SOURce]:SAFety:STEP<n>:SUB<s>:DCR:CORRection[:RESistance]:SHORT[:RANGe][:BEST] <number value>**

It sets the short resistance for the selected STEP. The unit is ohm and the valid range is -2MΩ~2MΩ. This command will set the short resistance of all ranges to this value. Please note that the device may clear this short resistance if the test parameter is changed. It is suggested to set this short resistance after all test parameters are set.

**[[:SOURce]:SAFety:STEP<n>[:MAIN]:DCR:CORRection[:RESistance]:SHORT[:RANGe][:BEST]?
[:SOURce]:SAFety:STEP<n>:SUB<s>:DCR:CORRection[:RESistance]:SHORT[:RANGe][:BEST]?**

It queries the short resistance of minimum resistance range for the selected STEP. The unit is ohm.

**[[:SOURce]:SAFety:STEP<n>[:MAIN]:DCR:CORRection[:RESistance]:SHORT[:RANGe]:ALL <range 1>,<range 2>,<range 3>,<range 4>,<range 5>,<range 6>,<range 7>,<range 8>,<range 9>
[:SOURce]:SAFety:STEP<n>:SUB<s>:DCR:CORRection[:RESistance]:SHORT[:RANGe]:ALL <range 1>,<range 2>,<range 3>,<range 4>,<range 5>,<range 6>,<range 7>,<range 8>,<range 9>**

It sets the short resistance of each range for the selected STEP. The unit is ohm and the valid range is -2MΩ~2MΩ. This command requires 9 parameters; the first parameter is the short resistance of minimum resistance range. Please note that the device may clear this short resistance if the test parameter is changed. It is suggested to set this short resistance after all test parameters are set.

**[[:SOURce]:SAFety:STEP<n>[:MAIN]:DCR:CORRection[:RESistance]:SHORT[:RANGe]:ALL?
[:SOURce]:SAFety:STEP<n>:SUB<s>:DCR:CORRection[:RESistance]:SHORT[:RANGe]:ALL?**

It queries the short resistance of selected STEP. The unit is ohm. This query command will return 9 short resistances with comma as the separator. The first is the short resistance of minimum resistance range.

**[[:SOURce:]SAFety:STEP<n>[:MAIN]:DCR:LIMit[:HIGH] <numeric value>
[:SOURce:]SAFety:STEP<n>:SUB<s>:DCR:LIMit[:HIGH] <numeric value>**

It sets the high limit of DC resistance for the selected STEP. The unit is ohm.

**[[:SOURce:]SAFety:STEP<n>[:MAIN]:DCR:LIMit[:HIGH]?
[:SOURce:]SAFety:STEP<n>:SUB<s>:DCR:LIMit[:HIGH]?**

It queries the high limit of DC resistance for the selected STEP. The unit is ohm.

**[[:SOURce:]SAFety:STEP<n>[:MAIN]:DCR:LIMit:LOW <numeric value> | OFF
[:SOURce:]SAFety:STEP<n>:SUB<s>:DCR:LIMit:LOW <numeric value> | OFF**

It sets the low limit of DC resistance for the selected STEP. The unit is ohm. The setting of Low limit is disabled when the parameter is OFF.

[:SOURce:]SAFety:STEP<n>[:MAIN]:DCR:LIMit:LOW?

[:SOURce:]SAFety:STEP<n>:SUB<s>:DCR:LIMit:LOW?

It queries the low limit of DC resistance for the selected STEP. The unit is ohm.

[:SOURce:]SAFety:STEP<n>[:MAIN]:DCR:RANGe:UPPer <numeric value>

[:SOURce:]SAFety:STEP<n>:SUB<s>:DCR:RANGe:UPPer <numeric value>

It sets the DC resistance range for test for the selected STEP. The unit is ohm. The set DC resistance range should be larger than the input DC resistance.

[:SOURce:]SAFety:STEP<n>[:MAIN]:DCR:RANGe:UPPer?

[:SOURce:]SAFety:STEP<n>:SUB<s>:DCR:RANGe:UPPer?

It queries the DC resistance range for test for the selected STEP. The unit is ohm.

[:SOURce:]SAFety:STEP<n>[:MAIN]:DCR:RANGe[:LOWer] <numeric value>

[:SOURce:]SAFety:STEP<n>:SUB<s>:DCR:RANGe[:LOWer] <numeric value>

It sets the DC resistance range for test for the selected STEP. The unit is ohm. The set DC resistance range should be smaller than the input DC resistance.

[:SOURce:]SAFety:STEP<n>[:MAIN]:DCR:RANGe[:LOWer]?

[:SOURce:]SAFety:STEP<n>:SUB<s>:DCR:RANGe[:LOWer]?

It queries the DC resistance range for test for the selected STEP. The unit is ohm.

[:SOURce:]SAFety:STEP<n>[:MAIN]:DCR:RANGe:AUTO <boolean> | ON |OFF

[:SOURce:]SAFety:STEP<n>:SUB<s>:DCR:RANGe:AUTO <boolean> | ON |OFF

It sets the DC resistance range for test to auto for the selected STEP.

[:SOURce:]SAFety:STEP<n>[:MAIN]:DCR:RANGe:AUTO?

[:SOURce:]SAFety:STEP<n>:SUB<s>:DCR:RANGe:AUTO?

It queries if the DC resistance range for test is set to auto for the selected STEP.

[:SOURce:]SAFety:STEP<n>[:MAIN]:DCR:TIME:DWELI <numeric value> | OFF

[:SOURce:]SAFety:STEP<n>:SUB<s>:DCR:TIME:DWELI <numeric value> | OFF

It sets the time required for DWELL for the selected STEP. The unit is second. The Dwell Time setting is disabled when the parameter is set to OFF.

[:SOURce:]SAFety:STEP<n>[:MAIN]:DCR:TIME:DWELI?

[:SOURce:]SAFety:STEP<n>:SUB<s>:DCR:TIME:DWELI?

It queries the time required for DWELL for the selected STEP. The unit is second.

[:SOURce:]SAFety:STEP<n>[:MAIN]:DCR:TIME:SWITCH <numeric value>

[:SOURce:]SAFety:STEP<n>:SUB<s>:DCR:TIME:SWITCH <numeric value>

It sets the SWITCH TIME required for the selected STEP. The unit is second. The SWITCH TIME is disabled when the parameter is set to OFF.

[:SOURce:]SAFety:STEP<n>[:MAIN]:DCR:TIME:SWITCH?

[:SOURce:]SAFety:STEP<n>:SUB<s>:DCR:TIME:SWITCH?

It queries the SWITCH TIME required for the selected STEP. The unit is second.

[:SOURce:]SAFety:STEP<n>[:MAIN]:DCR:TIME[:TEST] <numeric value> | OFF | KEY

[:SOURce:]SAFety:STEP<n>:SUB<s>:DCR:TIME[:TEST] <numeric value> | OFF | KEY

It sets the time required for test for the selected STEP. The unit is second. The TEST

TIME setting is disabled when the parameter is set to OFF. The test runs continuously when the parameter is set to KEY.

**[:SOURce]:SAFety:STEP<n>[:MAIN]:DCR:TIME[:TEST]?
[:SOURce]:SAFety:STEP<n>:SUB<s>:DCR:TIME[:TEST]?**

It queries the time required for test for the selected STEP. The unit is second. When DCR sets to OFF, the return value is 0 and it returns 9.91E37 when sets to KEY.

**[:SOURce]:SAFety:STEP<n>[:MAIN]:OSC:CHANnel[:HIGH] <channel_list>
[:SOURce]:SAFety:STEP<n>:SUB<s>:OSC:CHANnel[:HIGH] <channel_list>**

It sets the status of high voltage output channel during scan test for the selected STEP.

**[:SOURce]:SAFety:STEP<n>[:MAIN]:OSC:CHANnel[:HIGH]?
[:SOURce]:SAFety:STEP<n>:SUB<s>:OSC:CHANnel[:HIGH]?**

It queries the status of high voltage output channel during scan test for the selected STEP.

**[:SOURce]:SAFety:STEP<n>[:MAIN]:OSC:CHANnel:LOW <channel_list>
[:SOURce]:SAFety:STEP<n>:SUB<s>:OSC:CHANnel:LOW <channel_list>**

It sets the output status of common test channel (RTN/LOW) during scan for the selected STEP.

**[:SOURce]:SAFety:STEP<n>[:MAIN]:OSC:CHANnel:LOW?
[:SOURce]:SAFety:STEP<n>:SUB<s>:OSC:CHANnel:LOW?**

It queries the output status of common test channel (RTN/LOW) during scan for the selected STEP.

**[:SOURce]:SAFety:STEP<n>[:MAIN]:OSC:CORRection[:CAPacitance]:OPEN[:RANGe][:BEST] <number value>
[:SOURce]:SAFety:STEP<n>:SUB<s>:OSC:CORRection[:CAPacitance]:OPEN[:RANGe][:BEST] <number value>**

It sets the open capacitance for the selected STEP. The unit is farad and the valid range is 0~40nF. This command will set the open capacitance of all ranges to this value. Please note that the device may clear this open capacitance if the test parameter is changed. It is suggested to set this open capacitance after all test parameters are set.

**[:SOURce]:SAFety:STEP<n>[:MAIN]:OSC:CORRection[:CAPacitance]:OPEN[:RANGe][:BEST]?
[:SOURce]:SAFety:STEP<n>:SUB<s>:OSC:CORRection[:CAPacitance]:OPEN[:RANGe][:BEST]?**

It queries the open resistance of minimum capacitance range for the selected STEP. The unit is farad.

**[:SOURce]:SAFety:STEP<n>[:MAIN]:OSC:CORRection[:CAPacitance]:OPEN[:RANGe]:ALL <range 1>,<range 2>
[:SOURce]:SAFety:STEP<n>:SUB<s>:OSC:CORRection[:CAPacitance]:OPEN[:RANGe]:ALL <range 1>,<range 2>**

It sets the open capacitance of each range for the selected STEP. The unit is farad and the valid range is 0~40nF. This command requires 3 parameters; the first parameter is the open capacitance of minimum capacitance range. Please note that the device may clear this open capacitance if the test parameter is changed. It is suggested to set this open capacitance after all test parameters are set.

[:SOURce]:SAFety:STEP<n>[:MAIN]:OSC:CORRection[:CAPacitance]:OPEN[:RANGe]:ALL?

[:SOURce]:SAFety:STEP<n>:SUB<s>:OSC:CORRection[:CAPacitance]:OPEN[:RANGe]:ALL?

It queries the open capacitance of selected STEP. The unit is ohm. This query command will return 3 open capacitances with comma as the separator. The first is the open capacitance of minimum capacitance range.

[:SOURce]:SAFety:STEP<n>[:MAIN]:OSC:CORRection[:CAPacitance]:SAMPle <range>,<number value>

[:SOURce]:SAFety:STEP<n>:SUB<s>:OSC:CORRection[:CAPacitance]:SAMPle <range>,<number value>

It sets measurement range and standard capacitance for the selected STEP. This command requires 2 parameters. The first parameter is the measurement range and the valid range is 1 or 2. 1 is to select the minimum capacitance range. The second parameter is to set the standard capacitance in the unit of farad. The valid standard capacitances are varied with range as the table listed below.

Range	Minimum	Maximum
1	0.01nF	9.99nF
2	0.1nF	40.0nF

[:SOURce]:SAFety:STEP<n>[:MAIN]:OSC:CORRection[:CAPacitance]:SAMPle?

[:SOURce]:SAFety:STEP<n>:SUB<s>:OSC:CORRection[:CAPacitance]:SAMPle?

It queries the measurement range and standard capacitance of selected STEP. This query command will return 2 values with comma as the separator. The first value is the measurement range and the second is the standard capacitance in the unit of farad.

[:SOURce]:SAFety:STEP<n>[:MAIN]:OSC:LIMit[:OPEN] <numeric value>

[:SOURce]:SAFety:STEP<n>:SUB<s>:OSC:LIMit[:OPEN] <numeric value>

It sets the percentage of Open judgment for OSC for the selected STEP.

[:SOURce]:SAFety:STEP<n>[:MAIN]:OSC:LIMit[:OPEN]?

[:SOURce]:SAFety:STEP<n>:SUB<s>:OSC:LIMit[:OPEN]?

It queries the percentage of Open judgment for OSC for the selected STEP.

[:SOURce]:SAFety:STEP<n>[:MAIN]:OSC:LIMit:SHORT <numeric value> | OFF

[:SOURce]:SAFety:STEP<n>:SUB<s>:OSC:LIMit:SHORT <numeric value> | OFF

It sets the percentage of Short judgment for OSC for the selected STEP. The SHORT setting is disabled when the parameter is set to OFF.

[:SOURce]:SAFety:STEP<n>[:MAIN]:OSC:LIMit:SHORT?

[:SOURce]:SAFety:STEP<n>:SUB<s>:OSC:LIMit:SHORT?

It queries the percentage of Short judgment for OSC for the selected STEP.

[:SOURce]:SAFety:STEP<n>[:MAIN]:ICOMpare:CHANnel:CLEar

[:SOURce]:SAFety:STEP<n>:SUB<s>:ICOMpare:CHANnel:CLEar

It clears the high voltage output scan channel for the selected STEP.

[:SOURce]:SAFety:STEP<n>[:MAIN]:ICOMpare:CHANnel:GROup<m>

<numeric value 1>,<numeric value 2>

[:SOURce]:SAFety:STEP<n>:SUB<s>:ICOMpare:CHANnel:GROup<m>

<numeric value 1>,<numeric value 2>

It sets the channel of selected group in IWT COMPARE MODE. <m> is the group number and the range is 1~6. <number value 1> is the positive channel numbers which are 0, 1~10, 101~116 and 201~216. <number value 2> is the common test channel (RTN/LOW) numbers for scan which are 0, 1~10, 101~116 and 201~216.

[:SOURce]:SAFety:STEP<n>[:MAIN]:ICOMpare:CHANnel:GROup<m>?
[:SOURce]:SAFety:STEP<n>:SUB<s>:ICOMpare:CHANnel:GROup<m>?

It queries the selected group channel in IWT COMPARE MODE. <m> is the group number and the range is 1~6. There 3 columns of return data, the 1st is group number, the 2nd is high voltage output channel number, and the 3rd is common test channel (RTN/LOW) number. For instance, assuming the high voltage output channel of the 3rd group is set to 1 and the common test channel is set to 6, the query command is given as follows:

SAF:STEP1:ICOM:CHAN:GRO3?
 Command return data: 3,1,6

[:SOURce]:SAFety:STEP<n>[:MAIN]:ICOMpare:CORRection:FLUTter?
[:SOURce]:SAFety:STEP<n>:SUB<s>:ICOMpare:CORRection:FLUTter?

It queries the FLUTTER value of selected STEP during sampling.

[:SOURce]:SAFety:STEP<n>[:MAIN]:ICOMpare:CORRection:LAPLac?
[:SOURce]:SAFety:STEP<n>:SUB<s>:ICOMpare:CORRection:LAPLac?

It queries the LAPLAC value of selected STEP during sampling.

[:SOURce]:SAFety:STEP<n>[:MAIN]:ICOMpare:CORRection:OUTPut <voltage>
[:SOURce]:SAFety:STEP<n>:SUB<s>:ICOMpare:CORRection:OUTPut <voltage>

It sets the actual testing output voltage for the selected STEP. The value is different from the voltage on the DUT. The setting range is 0~7000V.

[:SOURce]:SAFety:STEP<n>[:MAIN]:ICOMpare:CORRection:OUTPut?
[:SOURce]:SAFety:STEP<n>:SUB<s>:ICOMpare:CORRection:OUTPut?

It queries the actual testing output voltage of the selected STEP.

[:SOURce]:SAFety:STEP<n>[:MAIN]:ICOMpare:CORRection:VOLTage?
[:SOURce]:SAFety:STEP<n>:SUB<s>:ICOMpare:CORRection:VOLTage?

It queries the pulse voltage of selected STEP during sampling.

[:SOURce]:SAFety:STEP<n>[:MAIN]:ICOMpare:CORRection[:WAVeform]:SAMPLe[:DATA] GET
[:SOURce]:SAFety:STEP<n>:SUB<s>:ICOMpare:CORRection[:WAVeform]:SAMPLe[:DATA] GET

It sets the sample get procedure for the selected STEP.

[:SOURce]:SAFety:STEP<n>[:MAIN]:ICOMpare:CORRection[:WAVeform]:SAMPLe:VALid?
[:SOURce]:SAFety:STEP<n>:SUB<s>:ICOMpare:CORRection[:WAVeform]:SAMPLe:VALid?

It queries if the sample waveform data of the selected STEP is valid when testing.

[:SOURce]:SAFety:STEP<n>[:MAIN]:ICOMpare:CORRection[:WAVeform]:SAMPLe[:DATA] <block data> | GET

It sets the sampling waveform data or starts sampling process for testing the selected STEP. When the parameter is set to GET, it means to start sampling process. When the

parameter is set to <block data>, it means to set the waveform data. The format of <block data> starts from "#0" followed by 512 dots waveform data and each dot is represented by 3 hexadecimal characters. The range is 000~3FF and the data length is 1538 (2+512x3) characters.

[[:SOURce]:SAFety:STEP<n>[:MAIN]:ICOMpare:CORREction[:WAVeform]:SAMPLe[:DATA]?]

It queries the sampling waveform data for testing the selected STEP. The return data format starts from "#0" followed by 512 dots waveform data and each dot is represented by 3 hexadecimal characters. The data length is 1538 (2+512x3) characters.

[[:SOURce]:SAFety:STEP<n>[:MAIN]:ICOMpare [:LEVel] <numeric value>]
[[:SOURce]:SAFety:STEP<n>:SUB<s>:ICOMpare [:LEVel] <numeric value>]

It sets the IWT COMPARE testing required voltage for the selected STEP. The unit is Volt.

[[:SOURce]:SAFety:STEP<n>[:MAIN]:ICOMpare [:LEVel]?]
[[:SOURce]:SAFety:STEP<n>:SUB<s>:ICOMpare [:LEVel]?]

It queries the IWT COMPARE testing required voltage for the selected STEP. The unit is Volt.

[[:SOURce]:SAFety:STEP<n>[:MAIN]:ICOMpare:WIDTh <numeric value>]
[[:SOURce]:SAFety:STEP<n>:SUB<s>:ICOMpare:WIDTh <numeric value>]

It sets the IWT COMPARE testing WIDTH for the selected STEP. The range is 1~11.

[[:SOURce]:SAFety:STEP<n>[:MAIN]:ICOMpare:WIDTh?]
[[:SOURce]:SAFety:STEP<n>:SUB<s>:ICOMpare:WIDTh?]

It queries the IWT COMPARE testing WIDTH of the selected STEP.

[[:SOURce]:SAFety:STEP<n>[:MAIN]:ICOMpare:PULSe <numeric value>]
[[:SOURce]:SAFety:STEP<n>:SUB<s>:ICOMpare:PULSe <numeric value>]

It sets the IWT COMPARE testing PULSE for the selected STEP. The range is 1.0~1.9.

[[:SOURce]:SAFety:STEP<n>[:MAIN]:ICOMpare:PULSe?]
[[:SOURce]:SAFety:STEP<n>:SUB<s>:ICOMpare:PULSe?]

It queries the IWT COMPARE testing PULSE of the selected STEP.

[[:SOURce]:SAFety:STEP<n>[:MAIN]:ICOMpare:AREA:SCOPE:BEgin <numeric value>]

[[:SOURce]:SAFety:STEP<n>:SUB<s>:ICOMpare:AREA:SCOPE:BEgin <numeric value>]

It sets the IWT COMPARE testing AREA BEGIN for the selected STEP. The setting range for BEGIN is 1~512.

[[:SOURce]:SAFety:STEP<n>[:MAIN]:ICOMpare:AREA:SCOPE:BEgin?]
[[:SOURce]:SAFety:STEP<n>:SUB<s>:ICOMpare:AREA:SCOPE:BEgin?]

It queries the IWT COMPARE testing AREA for the BEGIN setting of the selected STEP.

[[:SOURce]:SAFety:STEP<n>[:MAIN]:ICOMpare:AREA:SCOPE:END <numeric value>]

[[:SOURce]:SAFety:STEP<n>:SUB<s>:ICOMpare:AREA:SCOPE:END <numeric value>]

It sets the IWT COMPARE testing AREA END for the selected STEP. The setting range for END is 1~512.

[[:SOURce]:SAFety:STEP<n>[:MAIN]:ICOMpare:AREA:SCOPE:END?
[[:SOURce]:SAFety:STEP<n>:SUB<s>:ICOMpare:AREA:SCOPE:END?

It queries the IWT COMPARE testing AREA for the END setting of the selected STEP.

[[:SOURce]:SAFety:STEP<n>[:MAIN]:ICOMpare:AREA:LIMit:PLUS <numeric value> |OFF

[[:SOURce]:SAFety:STEP<n>:SUB<s>:ICOMpare:AREA:LIMit:PLUS <numeric value> |OFF

It sets the IWT COMPARE testing AREA LIMIT+ for the selected STEP. The setting range for LIMIT+ is 0.1%~99.9%. The LIMIT+ setting is disabled when set to OFF.

[[:SOURce]:SAFety:STEP<n>[:MAIN]:ICOMpare:AREA:LIMit:PLUS?
[[:SOURce]:SAFety:STEP<n>:SUB<s>:ICOMpare:AREA:LIMit:PLUS?

It queries the IWT COMPARE testing AREA for the LIMIT+ setting of the selected STEP.

[[:SOURce]:SAFety:STEP<n>[:MAIN]:ICOMpare:AREA:LIMit:MINus <numeric value> |OFF

[[:SOURce]:SAFety:STEP<n>:SUB<s>:ICOMpare:AREA:LIMit:MINus <numeric value> |OFF

It sets the IWT COMPARE testing AREA LIMIT- for the selected STEP. The setting range for LIMIT- is 0.1%~99.9%. The LIMIT- setting is disabled when set to OFF.

[[:SOURce]:SAFety:STEP<n>[:MAIN]:ICOMpare:AREA:LIMit:MINus?
[[:SOURce]:SAFety:STEP<n>:SUB<s>:ICOMpare:AREA:LIMit:MINus?

It queries the IWT COMPARE testing AREA for the LIMIT- setting of the selected STEP.

[[:SOURce]:SAFety:STEP<n>[:MAIN]:ICOMpare:DAREa:SCOPE:BEgin <numeric value>

[[:SOURce]:SAFety:STEP<n>:SUB<s>:ICOMpare:DAREa:SCOPE:BEgin <numeric value>

It sets the IWT COMPARE testing DIF-AREABEGIN for the selected STEP. The setting range for BEGIN is 1~512.

[[:SOURce]:SAFety:STEP<n>[:MAIN]:ICOMpare:DAREa:SCOPE:BEgin?
[[:SOURce]:SAFety:STEP<n>:SUB<s>:ICOMpare:DAREa:SCOPE:BEgin?

It queries the IWT COMPARE testing DIF-AREA for the BEGIN setting of the selected STEP.

[[:SOURce]:SAFety:STEP<n>[:MAIN]:ICOMpare:DAREa:SCOPE:END <numeric value>

[[:SOURce]:SAFety:STEP<n>:SUB<s>:ICOMpare:DAREa:SCOPE:END <numeric value>

It sets the IWT COMPARE testing DIF-AREA END for the selected STEP. The setting range for END is 1~512.

[[:SOURce]:SAFety:STEP<n>[:MAIN]:ICOMpare:DAREa:SCOPE:END?
[[:SOURce]:SAFety:STEP<n>:SUB<s>:ICOMpare:DAREa:SCOPE:END?

It queries the IWT COMPARE testing DIF-AREA for the END setting of the selected STEP.

[[:SOURce]:SAFety:STEP<n>[:MAIN]:ICOMpare:DAREa:LIMit <numeric value> |OFF

[[:SOURce]:SAFety:STEP<n>:SUB<s>:ICOMpare:DAREa:LIMit <numeric value>

|OFF

It sets the IWT COMPARE testing DIF-AREA LIMIT for the selected STEP. The setting range for LIMIT+ is 0.1%~99.9%. The LIMIT setting is disabled when set to OFF.

[[:SOURce]:SAFety:STEP<n>[:MAIN]:ICOMpare:DARea:LIMit?

[[:SOURce]:SAFety:STEP<n>:SUB<s>:ICOMpare:DARea:LIMit?

It queries the IWT COMPARE testing DIF-AREA for the LIMIT setting of the selected STEP.

[[:SOURce]:SAFety:STEP<n>[:MAIN]:ICOMpare:FLUTter:SCOPE:BEgin
<numeric value>

[[:SOURce]:SAFety:STEP<n>:SUB<s>:ICOMpare:FLUTter:SCOPE:BEgin **<numeric value>**

It sets the IWT COMPARE testing FLUTTER BEGIN for the selected STEP. The range is 1~512.

[[:SOURce]:SAFety:STEP<n>[:MAIN]:ICOMpare:FLUTter:SCOPE:BEgin?

[[:SOURce]:SAFety:STEP<n>:SUB<s>:ICOMpare:FLUTter:SCOPE:BEgin?

It queries the IWT COMPARE testing FLUTTER for the BEGIN setting of the selected STEP.

[[:SOURce]:SAFety:STEP<n>[:MAIN]:ICOMpare:FLUTter:SCOPE:END
<numeric value>

[[:SOURce]:SAFety:STEP<n>:SUB<s>:ICOMpare:FLUTter:SCOPE:END
<numeric value>

It sets the IWT COMPARE testing FLUTTER END for the selected STEP. The range is 1~512.

[[:SOURce]:SAFety:STEP<n>[:MAIN]:ICOMpare:FLUTter:SCOPE:END?

[[:SOURce]:SAFety:STEP<n>:SUB<s>:ICOMpare:FLUTter:SCOPE:END?

It queries the IWT COMPARE testing FLUTTER for the END setting of the selected STEP.

[[:SOURce]:SAFety:STEP<n>[:MAIN]:ICOMpare:FLUTter:LIMit **<numeric value>**
|OFF

[[:SOURce]:SAFety:STEP<n>:SUB<s>:ICOMpare:FLUTter:LIMit **<numeric value>** **|OFF**

It sets the IWT COMPARE testing FLUTTER LIMIT for the selected STEP. The range is 1~9999. The LIMIT setting is disabled when set to OFF.

[[:SOURce]:SAFety:STEP<n>[:MAIN]:ICOMpare:FLUTter:LIMit?

[[:SOURce]:SAFety:STEP<n>:SUB<s>:ICOMpare:FLUTter:LIMit?

It queries the IWT COMPARE testing FLUTTER for the LIMIT setting of the selected STEP.

[[:SOURce]:SAFety:STEP<n>[:MAIN]:ICOMpare:LAPLac:SCOPE:BEgin
<numeric value>

[[:SOURce]:SAFety:STEP<n>:SUB<s>:ICOMpare:LAPLac:SCOPE:BEgin
<numeric value>

It sets the IWT COMPARE testing LAPLAC BEGIN for the selected STEP. The range is 1~512.

[[:SOURce]:SAFety:STEP<n>[:MAIN]:ICOMpare:LAPLac:SCOPE:BEgin?

[[:SOURce]:SAFety:STEP<n>:SUB<s>:ICOMpare:LAPLac:SCOPE:BEgin?

It queries the IWT COMPARE testing LAPLAC for the BEGIN setting of the selected STEP.

**[[:SOURce]:SAFety:STEP<n>[:MAIN]: ICOMpare:LAPLac:SCOPE:END
<numeric value>**

**[[:SOURce]:SAFety:STEP<n>:SUB<s>: ICOMpare:LAPLac:SCOPE:END
<numeric value>**

It sets the IWT COMPARE testing LAPLAC END for the selected STEP. The range is 1~512.

**[[:SOURce]:SAFety:STEP<n>[:MAIN]:ICOMpare:LAPLac:SCOPE:END?
[:SOURce]:SAFety:STEP<n>:SUB<s>:ICOMpare:LAPLac:SCOPE:END?**

It queries the IWT COMPARE testing LAPLAC for the END setting of the selected STEP.

**[[:SOURce]:SAFety:STEP<n>[:MAIN]: ICOMpare:LAPLac:LIMit <numeric value>
|OFF**

**[[:SOURce]:SAFety:STEP<n>:SUB<s>: ICOMpare:LAPLac:LIMit <numeric
value> |OFF**

It sets the IWT COMPARE testing LAPLAC LIMIT for the selected STEP. The range is 1~9999. The LIMIT setting is disabled when set to OFF.

**[[:SOURce]:SAFety:STEP<n>[:MAIN]:ICOMpare:LAPLac:LIMit?
[:SOURce]:SAFety:STEP<n>:SUB<s>:ICOMpare:LAPLac:LIMit?**

It queries the IWT COMPARE testing LAPLAC for the LIMIT setting of the selected STEP.

**[[:SOURce]:SAFety:STEP<n>[:MAIN]:IWT:CHANnel[:HIGH] <channel_list>
[:SOURce]:SAFety:STEP<n>:SUB<s>:IWT:CHANnel[:HIGH] <channel_list>**

It sets the status of high voltage output channel during scan test for the selected STEP.

**[[:SOURce]:SAFety:STEP<n>[:MAIN]:IWT:CHANnel[:HIGH]?
[:SOURce]:SAFety:STEP<n>:SUB<s>:IWT:CHANnel[:HIGH]?**

It queries the status of high voltage output channel during scan test for the selected STEP.

**[[:SOURce]:SAFety:STEP<n>[:MAIN]:IWT:CHANnel:LOW <channel_list>
[:SOURce]:SAFety:STEP<n>:SUB<s>:IWT:CHANnel:LOW <channel_list>**

It sets the output status of common test channel (RTN/LOW) during scan for the selected STEP.

**[[:SOURce]:SAFety:STEP<n>[:MAIN]:IWT:CHANnel:LOW?
[:SOURce]:SAFety:STEP<n>:SUB<s>:IWT:CHANnel:LOW?**

It queries the output status of common test channel (RTN/LOW) during scan for the selected STEP.

**[[:SOURce]:SAFety:STEP<n>[:MAIN]:IWT:CORRection:FLUTtrt?
[:SOURce]:SAFety:STEP<n>:SUB<s>:IWT:CORRection:FLUTter?**

It queries the IWT sampling Flutter value of selected STEP.

**[[:SOURce]:SAFety:STEP<n>[:MAIN]:IWT:CORRection:LAPLac?
[:SOURce]:SAFety:STEP<n>:SUB<s>:IWT:CORRection:LAPLac?**

It queries the IWT sampling Laplac value of selected STEP.

[:SOURce]:SAFety:STEP<n>[:MAIN]:IWT:CORRection:OUTPut <voltage>
[:SOURce]:SAFety:STEP<n>:SUB<s>:IWT:CORRection:OUTPut <voltage>

It sets the actual output voltage which is different from the DUT voltage for selected STEP. The range is 0~7000V.

[:SOURce]:SAFety:STEP<n>[:MAIN]:IWT:CORRection:OUTPut?
[:SOURce]:SAFety:STEP<n>:SUB<s>:IWT:CORRection:OUTPut?

It queries the actual output voltage of selected STEP during IWT sampling.

[:SOURce]:SAFety:STEP[:MAIN]:IWT:CORRection:PRATio?

It queries the Peak Ratio of selected STEP during IWT sampling.

[:SOURce]:SAFety:STEP<n>[:MAIN]:IWT:CORRection[:WAVeform]:SAMPLe[:DATA] <block data> | GET
[:SOURce]:SAFety:STEP<n>:SUB<s>:IWT:CORRection[:WAVeform]:SAMPLe[:DATA] <block data> | GET

It sets the sampling waveform data or starts sampling process for testing the selected STEP. When the parameter is set to GET, it means to start sampling process. When the parameter is set to <block data>, it means to set the waveform data. The format of <block data> starts from "#0" followed by 512 dots waveform data and each dot is represented by 3 hexadecimal characters. The range is 000~3FF and the data length is 1538 (2+512x3) characters.

[:SOURce]:SAFety:STEP<n>[:MAIN]:IWT:CORRection[:WAVeform]:SAMPLe[:DATA]?

[:SOURce]:SAFety:STEP<n>:SUB<s>:IWT:CORRection[:WAVeform]:SAMPLe[:DATA]?

It queries the sampling waveform data for testing the selected STEP. The return data format starts from "#0" followed by 512 dots waveform data and each dot is represented by 3 hexadecimal characters. The data length is 1538 (2+512x3) characters.

[:SOURce]:SAFety:STEP<n>[:MAIN]:IWT:CORRection[:WAVeform]:SAMPLe:SCALE:UP?

[:SOURce]:SAFety:STEP<n>SUB<s>:IWT:CORRection[:WAVeform]:SAMPLe:SCALE:UP?

It queries the waveform data scale up ratio on display for the selected STEP. Use the following formula to convert the waveform data read by [DATA] command ranged from 0~1023 (000~3FF) to the -128~127 waveform data displayed by the analyzer.

$$\text{Display_Y} = ((\text{DATA} - 512) * \text{Scale_Up}) / \text{Scale_Down}$$

Display_Y: Y-axis data displayed on the instrument screen
 DATA: Data read by DATA? command
 Scale_Up: Data read by SCALE:UP? command
 Scale_Down: Data read by SCALE:DOWN? command

[:SOURce]:SAFety:STEP<n>[:MAIN]:IWT:CORRection[:WAVeform]:SAMPLe:SCALE:DOWN?

[:SOURce]:SAFety:STEP<n>SUB<s>:IWT:CORRection[:WAVeform]:SAMPLe:SCALE:DOWN?

It queries the waveform data scale down ratio on display for the selected STEP. Use the following formula to convert the waveform data read by [DATA] command ranged from 0~1023 (000~3FF) to the -128~127 waveform data displayed by the analyzer.

$$\text{Display_Y} = ((\text{DATA} - 512) * \text{Scale_Up}) / \text{Scale_Down}$$

Display_Y: Y-axis data displayed on the instrument screen
 DATA: Data read by DATA? command
 Scale_Up: Data read by SCALE:UP? command
 Scale_Down: Data read by SCALE:DOWN? command

[[:SOURce]:SAFety:STEP<n>[:MAIN]:IWT:CORRection[:WAVeform]:SAMPLe:VALId?

[[:SOURce]:SAFety:STEP<n>:SUB<s>:IWT:CORRection[:WAVeform]:SAMPLe:VALId?

It queries if the sampling waveform data exists for testing the selected STEP.

[[:SOURce]:SAFety:STEP<n>[:MAIN]:IWT:CORRection[:WAVeform]:SAMPLe:VOLTage?

[[:SOURce]:SAFety:STEP<n>:SUB<s>:IWT:CORRection[:WAVeform]:SAMPLe:VOLTage?

It queries the sampling waveform data for testing the selected STEP. The return data is 512 points voltage that uses 13 characters index format to send out each voltage entry. Each voltage entry is separated by comma (,) and the data length is 7167 ((13+1)x511+13) characters.

[[:SOURce]:SAFety:STEP<n>[:MAIN]:IWT[:LEVe] <numeric value>

[[:SOURce]:SAFety:STEP<n>:SUB<s>:IWT[:LEVe] <numeric value>

It sets the voltage required for IWT test for selected STEP. The unit is Volt.

[[:SOURce]:SAFety:STEP<n>[:MAIN]:IWT[:LEVe]?

[[:SOURce]:SAFety:STEP<n>:SUB<s>:IWT[:LEVe]?

It queries the voltage required for IWT test for selected STEP.

[[:SOURce]:SAFety:STEP<n>[:MAIN]:IWT:WIDTh <numeric value>

[[:SOURce]:SAFety:STEP<n>:SUB<s>:IWT:WIDTh <numeric value>

It sets the WIDTH of IWT test for selected STEP. The setting range is 1~11.

[[:SOURce]:SAFety:STEP<n>[:MAIN]:IWT:WIDTh?

[[:SOURce]:SAFety:STEP<n>:SUB<s>:IWT:WIDTh?

It queries the WIDTH of IWT test for selected STEP.

[[:SOURce]:SAFety:STEP<n>[:MAIN]:IWT:PULSe <numeric value>

[[:SOURce]:SAFety:STEP<n>:SUB<s>:IWT:PULSe <numeric value>

It sets the PULSE of IWT test for selected STEP. The setting range is 1.0~32.9.

[[:SOURce]:SAFety:STEP<n>[:MAIN]:IWT:PULSe?

[[:SOURce]:SAFety:STEP<n>:SUB<s>:IWT:PULSe?

It queries the PULSE of IWT test for selected STEP.

[[:SOURce]:SAFety:STEP<n>[:MAIN]:IWT:AREA:SCOPE:BEgIn <numeric value>

[[:SOURce]:SAFety:STEP<n>:SUB<s>:IWT:AREA:SCOPE:BEgIn <numeric value>

It sets the BEGIN scope in AREA condition during IWT test for the selected STEP. The setting range is 1~512.

[[:SOURce]:SAFety:STEP<n>[:MAIN]:IWT:AREA:SCOPE:BEgIn?

[[:SOURce]:SAFety:STEP<n>:SUB<s>:IWT:AREA:SCOPE:BEgIn?

It queries the BEGIN scope AREA condition during IWT test for the selected STEP.

[:SOURce]:SAFety:STEP<n>[:MAIN]:IWT:AREA:SCOPE:END <numeric value>
[:SOURce]:SAFety:STEP<n>:SUB<s>:IWT:AREA:SCOPE:END <numeric value>
It sets the END scope in AREA condition during IWT test for the selected STEP. The setting range is 1~512.

[:SOURce]:SAFety:STEP<n>[:MAIN]:IWT:AREA:SCOPE:END?
[:SOURce]:SAFety:STEP<n>:SUB<s>:IWT:AREA:SCOPE:END?
It queries the END scope in AREA condition during IWT test for the selected STEP.

[:SOURce]:SAFety:STEP<n>[:MAIN]:IWT:AREA:LIMit:PLUS <numeric value> |OFF
[:SOURce]:SAFety:STEP<n>:SUB<s>:IWT:AREA:LIMit:PLUS <numeric value>
|OFF
It sets the LIMIT+ in AREA condition during IWT Test for the selected STEP. The setting range is 0.1%~99.9% and it disables the LIMIT+ setting when the parameter is set to OFF.

[:SOURce]:SAFety:STEP<n>[:MAIN]:IWT:AREA:LIMit:PLUS?
[:SOURce]:SAFety:STEP<n>:SUB<s>:IWT:AREA:LIMit:PLUS?
It queries the LIMIT+ in AREA condition during IWT Test for the selected STEP.

[:SOURce]:SAFety:STEP<n>[:MAIN]:IWT:AREA:LIMit:MINus <numeric value>
|OFF
[:SOURce]:SAFety:STEP<n>:SUB<s>:IWT:AREA:LIMit:MINus <numeric value>
|OFF
It sets the LIMIT- in AREA condition during IWT Test for the selected STEP. The setting range is 0.1%~99.9% and it disables the LIMIT- setting when the parameter is set to OFF.

[:SOURce]:SAFety:STEP<n>[:MAIN]:IWT:AREA:LIMit:MINus?
[:SOURce]:SAFety:STEP<n>:SUB<s>:IWT:AREA:LIMit:MINus?
It queries the LIMIT- in AREA condition during IWT Test for the selected STEP.

[:SOURce]:SAFety:STEP<n>[:MAIN]:IWT:DAREa:SCOPE:BEgIn <numeric value>
[:SOURce]:SAFety:STEP<n>:SUB<s>:IWT:DAREa:SCOPE:BEgIn <numeric value>
It sets the BEGIN scope in DIF-AREA condition during IWT test for the selected STEP. The setting range is 1~512.

[:SOURce]:SAFety:STEP<n>[:MAIN]:IWT:DAREa:SCOPE:BEgIn?
[:SOURce]:SAFety:STEP<n>:SUB<s>:IWT:DAREa:SCOPE:BEgIn?
It queries the BEGIN scope DIF-AREA condition during IWT test for the selected STEP.

[:SOURce]:SAFety:STEP<n>[:MAIN]:IWT:DAREa:SCOPE:END <numeric value>
[:SOURce]:SAFety:STEP<n>:SUB<s>:IWT:DAREa:SCOPE:END <numeric value>
It sets the END scope in DIF-AREA condition during IWT test for the selected STEP. The setting range is 1~512.

[:SOURce]:SAFety:STEP<n>[:MAIN]:IWT:DAREa:SCOPE:END?
[:SOURce]:SAFety:STEP<n>:SUB<s>:IWT:DAREa:SCOPE:END?
It queries the END scope in DIF-AREA condition during IWT test for the selected STEP.

[:SOURce]:SAFety:STEP<n>[:MAIN]:IWT:DAREa:LIMit <numeric value> |OFF
[:SOURce]:SAFety:STEP<n>:SUB<s>:IWT:DAREa:LIMit <numeric value> |OFF
It sets the LIMIT in DIF-AREA condition during IWT Test for the selected STEP. The setting range is 0.1%~99.9% and it disables the LIMIT setting when the parameter is set

to OFF.

[:SOURce]:SAFety:STEP<n>[:MAIN]:IWT:DARea:LIMit?
[:SOURce]:SAFety:STEP<n>:SUB<s>:IWT:DARea:LIMit?

It queries the LIMIT in DIF-AREA condition during IWT Test for the selected STEP.

[:SOURce]:SAFety:STEP<n>[:MAIN]:IWT:FLUTter:SCOPE:BEgin <numeric value>
[:SOURce]:SAFety:STEP<n>:SUB<s>:IWT:FLUTter:SCOPE:BEgin <numeric value>

It sets the BEGIN scope in FLUTTER condition during IWT test for the selected STEP.
 The setting range is 1~512.

[:SOURce]:SAFety:STEP<n>[:MAIN]:IWT:FLUTter:SCOPE:BEgin?
[:SOURce]:SAFety:STEP<n>:SUB<s>:IWT:FLUTter:SCOPE:BEgin?

It queries the BEGIN scope in FLUTTER condition during IWT test for the selected STEP.

[:SOURce]:SAFety:STEP<n>[:MAIN]:IWT:FLUTter:SCOPE:END <numeric value>
[:SOURce]:SAFety:STEP<n>:SUB<s>:IWT:FLUTter:SCOPE:END <numeric value>

It sets the END scope in FLUTTER condition during IWT test for the selected STEP. The setting range is 1~512.

[:SOURce]:SAFety:STEP<n>[:MAIN]:IWT:FLUTter:SCOPE:END?
[:SOURce]:SAFety:STEP<n>:SUB<s>:IWT:FLUTter:SCOPE:END?

It queries the END scope in FLUTTER condition during IWT test for the selected STEP.

[:SOURce]:SAFety:STEP<n>[:MAIN]:IWT:FLUTter:LIMit <numeric value> |OFF
[:SOURce]:SAFety:STEP<n>:SUB<s>:IWT:FLUTter:LIMit <numeric value> |OFF

It sets the LIMIT in FLUTTER condition during IWT Test for the selected STEP. The setting range is 1~9999 and it disables the LIMIT setting when the parameter is set to OFF.

[:SOURce]:SAFety:STEP<n>[:MAIN]:IWT:FLUTter:LIMit?
[:SOURce]:SAFety:STEP<n>:SUB<s>:IWT:FLUTter:LIMit?

It queries the LIMIT in FLUTTER condition during IWT Test for the selected STEP.

[:SOURce]:SAFety:STEP<n>[:MAIN]:IWT:LAPLac:SCOPE:BEgin <numeric value>
[:SOURce]:SAFety:STEP<n>:SUB<s>:IWT:LAPLac:SCOPE:BEgin <numeric value>

It sets the BEGIN scope in LAPLAC condition during IWT test for the selected STEP.
 The setting range is 1~512.

[:SOURce]:SAFety:STEP<n>[:MAIN]:IWT:LAPLac:SCOPE:BEgin?
[:SOURce]:SAFety:STEP<n>:SUB<s>:IWT:LAPLac:SCOPE:BEgin?

It queries the BEGIN scope in LAPLAC condition during IWT test for the selected STEP.

[:SOURce]:SAFety:STEP<n>[:MAIN]:IWT:LAPLac:SCOPE:END <numeric value>
[:SOURce]:SAFety:STEP<n>:SUB<s>:IWT:LAPLac:SCOPE:END <numeric value>

It sets the END scope in LAPLAC condition during IWT test for the selected STEP. The setting range is 1~512.

[:SOURce]:SAFety:STEP<n>[:MAIN]:IWT:LAPLac:SCOPE:END?
[:SOURce]:SAFety:STEP<n>:SUB<s>:IWT:LAPLac:SCOPE:END?

It queries the END scope in LAPLAC condition during IWT test for the selected STEP.

[[:SOURce]:SAFety:STEP<n>[:MAIN]:IWT:LAPLac:LIMit <numeric value> |OFF
[[:SOURce]:SAFety:STEP<n>:SUB<s>:IWT:LAPLac:LIMit <numeric value> |OFF

It sets the LIMIT in LAPLAC condition during IWT Test for the selected STEP. The setting range is 1~9999 and it disables the LIMIT setting when the parameter is set to OFF.

[[:SOURce]:SAFety:STEP<n>[:MAIN]:IWT:LAPLac:LIMit?
[[:SOURce]:SAFety:STEP<n>:SUB<s>:IWT:LAPLac:LIMit?

It queries the LIMIT in LAPLAC condition during IWT Test for the selected STEP.

[[:SOURce]:SAFety:STEP<n>[:MAIN]:IWT:DPRATio:LIMit:MINus <numeric value>|OFF
[[:SOURce]:SAFety:STEP<n>:SUB<s>:IWT:DPRATio:LIMit:MINus <numeric value>|OFF

It sets the LIMIT- setting for judging Δ PEAK% during IWT test. The setting range is .001~0.999 and it disables the LIMIT- setting when the parameter is set to OFF.

[[:SOURce]:SAFety:STEP<n> [:MAIN]:IWT:DPRATio:LIMit:MINus?
[[:SOURce]:SAFety:STEP<n>:SUB<s>:IWT:DPRATio:LIMit:MINus?

It queries the LIMIT- setting for judging Δ PEAK% during IWT test.

[[:SOURce]:SAFety:STEP<n> [:MAIN]:IWT:DPRATio:LIMit:PLUS <numeric value> |OFF
[[:SOURce]:SAFety:STEP<n>:SUB<s>:IWT:DPRATio:LIMit:PLUS <numeric value> |OFF

It sets the LIMIT+ setting for judging Δ PEAK% during IWT test. The setting range is .001~0.999 and it disables the LIMIT+ setting when the parameter is set to OFF.

[[:SOURce]:SAFety:STEP<n> [:MAIN]:IWT:DPRATio:LIMit:PLUS?
[[:SOURce]:SAFety:STEP<n>:SUB<s>:IWT:DPRATio:LIMit:PLUS?

It queries the LIMIT+ setting for judging Δ PEAK% during IWT test.

[[:SOURce]:SAFety:STEP<n> [:MAIN]:IWT:DRArea:LIMit:MINus <numeric value> |OFF
[[:SOURce]:SAFety:STEP<n>:SUB<s>:IWT:DRArea:LIMit:MINus <numeric value> |OFF

It sets the LIMIT- setting for judging Δ R.Area during IWT test. The setting range is .001~0.999 and it disables the LIMIT- setting when the parameter is set to OFF.

[[:SOURce]:SAFety:STEP<n> [:MAIN]:IWT:DRArea:LIMit:MINus?
[[:SOURce]:SAFety:STEP<n>:SUB<s>:IWT:DRArea:LIMit:MINus?

It queries the LIMIT- setting for judging Δ R.Area during IWT test.

[[:SOURce]:SAFety:STEP<n> [:MAIN]:IWT:DRArea:LIMit:PLUS <numeric value> |OFF
[[:SOURce]:SAFety:STEP<n>:SUB<s>:IWT:DRArea:LIMit:PLUS <numeric value> |OFF

It sets the LIMIT+ setting for judging Δ R.Area during IWT test. The setting range is .001~0.999 and it disables the LIMIT- setting when the parameter is set to OFF.

[[:SOURce]:SAFety:STEP<n> [:MAIN]:IWT:DRArea:LIMit:PLUS?
[[:SOURce]:SAFety:STEP<n>:SUB<s>:IWT:DRArea:LIMit:PLUS?

It queries the LIMIT+ setting for judging ΔR .Area during IWT test.

[[:SOURce]:SAFety:STEP<n> [:MAIN]:IWT:DFREQuency:LIMit:MINus <numeric value> |OFF

[[:SOURce]:SAFety:STEP<n>:SUB<s>:IWT:DFREQuency:LIMit:MINus <numeric value> |OFF

It sets the LIMIT- setting for judging $\Delta FREQ$ during IWT test. The setting range is .001~0.999 and it disables the LIMIT- setting when the parameter is set to OFF.

[[:SOURce]:SAFety:STEP<n> [:MAIN]:IWT:DFREQuency:LIMit:MINus?

[[:SOURce]:SAFety:STEP<n>:SUB<s>:IWT:DFREQuency:LIMit:MINus?

It queries the LIMIT- setting for judging $\Delta FREQ$ during IWT test.

[[:SOURce]:SAFety:STEP<n> [:MAIN]:IWT:DFREQuency:LIMit:PLUS <numeric value> |OFF

[[:SOURce]:SAFety:STEP<n>:SUB<s>:IWT:DFREQuency:LIMit:PLUS <numeric value> |OFF

It sets the LIMIT+ setting for judging $\Delta FREQ$ during IWT test. The setting range is .001~0.999 and it disables the LIMIT- setting when the parameter is set to OFF.

[[:SOURce]:SAFety:STEP<n> [:MAIN]:IWT:DFREQuency:LIMit:PLUS?

[[:SOURce]:SAFety:STEP<n>:SUB<s>:IWT:DFREQuency:LIMit:PLUS?

It queries the LIMIT+ setting for judging $\Delta FREQ$ during IWT test.

[[:SOURce]:SAFety:STEP<n>[:MAIN]:LX:CHANnel[:HIGH] <channel_list>

[[:SOURce]:SAFety:STEP<n>:SUB<s>:LX:CHANnel[:HIGH] <channel_list>

It sets the high voltage output scan channel for the selected STEP.

[[:SOURce]:SAFety:STEP<n>[:MAIN]:LX:CHANnel[:HIGH]?

[[:SOURce]:SAFety:STEP<n>:SUB<s>:LX:CHANnel[:HIGH]?

It queries the high voltage output scan channel of the selected STEP.

[[:SOURce]:SAFety:STEP<n>[:MAIN]:LX:CHANnel:LOW <channel_list>

[[:SOURce]:SAFety:STEP<n>:SUB<s>:LX:CHANnel:LOW <channel_list>

It sets the output status of common test scan channel (RTN/LOW) for the selected STEP.

[[:SOURce]:SAFety:STEP<n>[:MAIN]:LX:CHANnel:LOW?

[[:SOURce]:SAFety:STEP<n>:SUB<s>:LX:CHANnel:LOW?

It queries the output status of common test scan channel (RTN/LOW) for the selected STEP.

[[:SOURce]:SAFety:STEP<n>[:MAIN]:LX:LIMit[:LX]:HIGH <numeric value>

[[:SOURce]:SAFety:STEP<n>:SUB<s>:LX:LIMit[:LX]:HIGH <numeric value>

It sets the Lx mode inductance high limit for the selected STEP. The unit is Henry.

[[:SOURce]:SAFety:STEP<n>[:MAIN]:LX:LIMit[:LX]:HIGH?

[[:SOURce]:SAFety:STEP<n>:SUB<s>:LX:LIMit[:LX]:HIGH?

It queries the Lx mode inductance high limit for the selected STEP. The unit is Henry.

[[:SOURce]:SAFety:STEP<n>[:MAIN]:LX:LIMit[:LX]:LOW <numeric value>

[[:SOURce]:SAFety:STEP<n>:SUB<s>:LX:LIMit[:LX]:LOW <numeric value>

It sets the Lx mode inductance low limit for the selected STEP. The unit is Henry.

[:SOURce]:SAFety:STEP<n>[:MAIN]:LX:LIMit[:LX]:LOW?
[:SOURce]:SAFety:STEP<n>:SUB<s>:LX:LIMit[:LX]:LOW?

It queries the Lx mode inductance low limit for the selected STEP. The unit is Henry.

[:SOURce]:SAFety:STEP<n>[:MAIN]:LX:LIMit:Q:HIGH <numeric value>
[:SOURce]:SAFety:STEP<n>:SUB<s>:LX:LIMit:Q:HIGH <numeric value>

It sets the Lx mode Q high limit for the selected STEP.

[:SOURce]:SAFety:STEP<n>[:MAIN]:LX:LIMit:Q:HIGH?
[:SOURce]:SAFety:STEP<n>:SUB<s>:LX:LIMit:Q:HIGH?

It queries the Lx mode Q high limit for the selected STEP.

[:SOURce]:SAFety:STEP<n>[:MAIN]:LX:LIMit:Q:LOW <numeric value>
[:SOURce]:SAFety:STEP<n>:SUB<s>:LX:LIMit:Q:LOW <numeric value>

It sets the Lx mode Q low limit for the selected STEP.

[:SOURce]:SAFety:STEP<n>[:MAIN]:LX:LIMit:Q:LOW?
[:SOURce]:SAFety:STEP<n>:SUB<s>:LX:LIMit:Q:LOW?

It queries the Lx mode Q low limit for the selected STEP.

[:SOURce]:SAFety:STEP<n>[:MAIN]:LBALance:CHANnel:CLEar
[:SOURce]:SAFety:STEP<n>:SUB<s>:LBALance:CHANnel:CLEar

It clears the high voltage output scan channel for the selected STEP.

[:SOURce]:SAFety:STEP<n>[:MAIN]:LBALance:CHANnel:GROup<m>
<numeric value 1>,<numeric value 2>
[:SOURce]:SAFety:STEP<n>:SUB<s>:LBALance:CHANnel:GROup<m>
<numeric value 1>,<numeric value 2>

It sets the group channel selected in Lx Balance mode. <m> is the group number and the range is 1~32. <number value 1> is the positive channel number 0, 1~10, 101~116 and 201~216. <number value 2> is the common scan channel (RTN/LOW) number 0, 1~10, 101~116 and 201~216.

[:SOURce]:SAFety:STEP<n>[:MAIN]:LBALance:CHANnel:GROup<m>?
[:SOURce]:SAFety:STEP<n>:SUB<s>:LBALance:CHANnel:GROup<m>?

It queries the group channel selected in Lx Balance mode , <m> is the group number and the range is 1~32. There 3 columns of return data, the 1st is group number, the 2nd is high voltage output channel number, and the 3rd is common test channel (RTN/LOW) number. For instance, assuming the high voltage output channel of the 3rd group is set to 1 and the common test channel is set to 6, the query command is given as follows:

SAF:STEP1:LBAL:CHAN:GRO3?
 Command return data: 3,1,6

[:SOURce]:SAFety:STEP<n>[:MAIN]:LBALance:LIMit:ABS <value> | OFF
[:SOURce]:SAFety:STEP<n>:SUB<s>:LBALance:LIMit:ABS <value> | OFF

It sets the inductance difference high limit in Lx Balance mode for the selected STEP. The unit is Henry.

[:SOURce]:SAFety:STEP<n>[:MAIN]:LBALance:LIMit:ABS?
[:SOURce]:SAFety:STEP<n>:SUB<s>:LBALance:LIMit:ABS?

It queries the inductance difference high limit in Lx Balance mode for the selected STEP. The unit is Henry.

[:SOURce]:SAFety:STEP<n>[:MAIN]:LBALance:LIMit:PERCent <value> | OFF
[:SOURce]:SAFety:STEP<n>:SUB<s>:LBALance:LIMit:PERCent <value> | OFF
 It sets the inductance difference percentage high limit in Lx Balance mode for the selected STEP.

[:SOURce]:SAFety:STEP<n>[:MAIN]:LBALance:LIMit:PERCent?
[:SOURce]:SAFety:STEP<n>:SUB<s>:LBALance:LIMit:PERCent?
 It queries the inductance difference percentage high limit in Lx Balance mode for the selected STEP.

[:SOURce]:SAFety:STEP<n>[:MAIN]:LBALance:TYPE ABS | PERCent
[:SOURce]:SAFety:STEP<n>:SUB<s>:LBALance:TYPE ABS | PERCent
 It sets the Lx Balance mode type for the selected STEP.

[:SOURce]:SAFety:STEP<n>[:MAIN]:LBALance:TYPE?
[:SOURce]:SAFety:STEP<n>:SUB<s>:LBALance:TYPE?
 It queries Lx Balance mode type for the selected STEP.

[:SOURce]:SAFety:STEP<n>[:MAIN]:PA[:MESSAge] <string data>
[:SOURce]:SAFety:STEP<n>:SUB<s>:PA[:MESSAge] <string data>
 It sets the message string of PA MODE.

[:SOURce]:SAFety:STEP<n>[:MAIN]:PA[:MESSAge]?
[:SOURce]:SAFety:STEP<n>:SUB<s>:PA[:MESSAge]?
 It queries the message string of PA MODE.

[:SOURce]:SAFety:STEP<n>[:MAIN]:PA:TIME[:TEST] <numeric value> | KEY
[:SOURce]:SAFety:STEP<n>:SUB<s>:PA:TIME[:TEST] <numeric value> | KEY
 It sets the execution time of PA MODE. The unit is second. The test runs continuously when the parameter is set to CONTInue.

[:SOURce]:SAFety:STEP<n>[:MAIN]:PA:TIME[:TEST]?
[:SOURce]:SAFety:STEP<n>:SUB<s>:PA:TIME[:TEST]?
 It queries the execution time of PA MODE. The unit is second.

[:SOURce]:SAFety:STEP<n>[:MAIN]:ECONnect[:MESSAge] <string data>
[:SOURce]:SAFety:STEP<n>:SUB<s>:ECONnect[:MESSAge] <string data>
 It sets the message string of EXTERIOR CONNECT mode.

[:SOURce]:SAFety:STEP<n>[:MAIN]:ECONnect[:MESSAge]?
[:SOURce]:SAFety:STEP<n>:SUB<s>:ECONnect[:MESSAge]?
 It queries the message string of EXTERIOR CONNECT mode.

[:SOURce]:SAFety:STEP<n>[:MAIN]:ECONnect:CHANnel[:HIGH] <channel_list>
[:SOURce]:SAFety:STEP<n>:SUB<s>:ECONnect:CHANnel[:HIGH] <channel_list>
 It sets the status of scan tested high voltage output channel for the selected STEP.

[:SOURce]:SAFety:STEP<n>[:MAIN]:ECONnect:CHANnel[:HIGH]?
[:SOURce]:SAFety:STEP<n>:SUB<s>:ECONnect:CHANnel[:HIGH]?
 It queries the status of scan tested high voltage output channel for the selected STEP.

[:SOURce]:SAFety:STEP<n>[:MAIN]:ECONnect:CHANnel:LOW <channel_list>
[:SOURce]:SAFety:STEP<n>:SUB<s>:ECONnect:CHANnel:LOW <channel_list>

It sets the output status of scanned common test channel (RTN/LOW) for the selected STEP.

[:SOURce]:SAFety:STEP<n>[:MAIN]:ECONnect:CHANnel:LOW?
[:SOURce]:SAFety:STEP<n>:SUB<s>:ECONnect:CHANnel:LOW?

It queries the output status of scanned common test channel (RTN/LOW) for the selected STEP.

[:SOURce]:SAFety:STEP<n>[:MAIN]:HSCC:CHANnel:CLEar
[:SOURce]:SAFety:STEP<n>:SUB<s>:HSCC:CHANnel:CLEar

It clears the selected STEP for the scanning test high voltage output channel status

[:SOURce]:SAFety:STEP<n>[:MAIN]:HSCC:CHANnel:GROup<m> <numeric value 1>,<numeric value 2>
[:SOURce]:SAFety:STEP<n>:SUB<s>:HSCC:CHANnel:GROup<m> <numeric value 1>,<numeric value 2>

It sets the channel status of selected group in HSCC MODE. <m> is the group no. and the range is 1~40. <number value 1> is the positive channel no. and the value is 0, 1~10, 101~116 and 201~216. <number value 2> is the no. of common scanning test channel (RTN/LOW) and the value is 0, 1~10, 101~116 and 201~216.

[:SOURce]:SAFety:STEP<n>[:MAIN]:HSCC:CHANnel:GROup<m>?
[:SOURce]:SAFety:STEP<n>:SUB<s>:HSCC:CHANnel:GROup<m>?

It queries the channel status of selected group in HSCC MODE. <m> is the group no. and the range is 1~40. There 3 columns of return data, the 1st is group number, the 2nd is high voltage output channel number, and the 3rd is common test channel (RTN/LOW) number. For instance, assuming the high voltage output channel of the 3rd group is set to 1 and the common test channel is set to 6, the query command is given as follows:

SAF:STEP1:HSCC:CHAN:GRO3?
 Command return data: 3,1,6

[:SOURce]:SAFety:STEP<n>[:MAIN]:YDELta:CHANnel:A <channel_list>
[:SOURce]:SAFety:STEP<n>:SUB<s>:YDELta:CHANnel:A <channel_list>

It sets the A channel status of scanning test for the selected STEP.

[:SOURce]:SAFety:STEP<n>[:MAIN]:YDELta:CHANnel:A?
[:SOURce]:SAFety:STEP<n>:SUB<s>:YDELta:CHANnel:A?

It queries the A channel status of scanning test for the selected STEP.

[:SOURce]:SAFety:STEP<n>[:MAIN]:YDELta:CHANnel:B <channel_list>
[:SOURce]:SAFety:STEP<n>:SUB<s>:YDELta:CHANnel:B <channel_list>

It sets the B channel status of scanning test for the selected STEP.

[:SOURce]:SAFety:STEP<n>[:MAIN]:YDELta:CHANnel:B?
[:SOURce]:SAFety:STEP<n>:SUB<s>:YDELta:CHANnel:B?

It queries the B channel status of scanning test for the selected STEP.

[:SOURce]:SAFety:STEP<n>[:MAIN]:YDELta:CHANnel:C <channel_list>
[:SOURce]:SAFety:STEP<n>:SUB<s>:YDELta:CHANnel:C <channel_list>

It sets the C channel status of scanning test for the selected STEP.

[:SOURce]:SAFety:STEP<n>[:MAIN]:YDELta:CHANnel:C?
[:SOURce]:SAFety:STEP<n>:SUB<s>:YDELta:CHANnel:C?

It queries the C channel status of scanning test for the selected STEP.

[:SOURce]:SAFety:STEP<n>[:MAIN]:YDELta:LIMit:RAB[:HIGH] <numeric value>
[:SOURce]:SAFety:STEP<n>:SUB<s>:YDELta:LIMit:RAB[:HIGH] <numeric value>

It sets the high limit of R1/Rab in Y/Delta mode for the selected STEP. The unit is Ohm.

[:SOURce]:SAFety:STEP<n>[:MAIN]:YDELta:LIMit:RAB[:HIGH]?
[:SOURce]:SAFety:STEP<n>:SUB<s>:YDELta:LIMit:RAB[:HIGH]?

It queries the high limit of R1/Rab in Y/Delta mode for the selected STEP. The unit is Ohm.

[:SOURce]:SAFety:STEP<n>[:MAIN]:YDELta:LIMit:RAB:LOW <numeric value>
| OFF
[:SOURce]:SAFety:STEP<n>:SUB<s>:YDELta:LIMit:RAB:LOW <numeric value>
| OFF

It sets the low limit of R1/Rab in Y/Delta mode for the selected STEP. The unit is Ohm.
 The setting of low limit is turned off when the parameter is set to OFF.

[:SOURce]:SAFety:STEP<n>[:MAIN]:YDELta:LIMit:RAB:LOW?
[:SOURce]:SAFety:STEP<n>:SUB<s>:YDELta:LIMit:RAB:LOW?

It queries the low limit of R1/Rab in Y/Delta mode for the selected STEP. The unit is Ohm.

[:SOURce]:SAFety:STEP<n>[:MAIN]:YDELta:LIMit:RBC[:HIGH] <numeric value>
[:SOURce]:SAFety:STEP<n>:SUB<s>:YDELta:LIMit:RBC[:HIGH] <numeric value>

It sets the high limit of R2/Rbc in Y/Delta mode for the selected STEP. The unit is Ohm.

[:SOURce]:SAFety:STEP<n>[:MAIN]:YDELta:LIMit:RBC[:HIGH]?
[:SOURce]:SAFety:STEP<n>:SUB<s>:YDELta:LIMit:RBC[:HIGH]?

It queries the high limit of R2/Rbc in Y/Delta mode for the selected STEP. The unit is Ohm.

[:SOURce]:SAFety:STEP<n>[:MAIN]:YDELta:LIMit:RBC:LOW <numeric value>
| OFF
[:SOURce]:SAFety:STEP<n>:SUB<s>:YDELta:LIMit:RBC:LOW <numeric value>
| OFF

It sets the low limit of R2/Rbc in Y/Delta mode for the selected STEP. The unit is Ohm.
 The setting of Low limit is turned off when the parameter is set to OFF.

[:SOURce]:SAFety:STEP<n>[:MAIN]:YDELta:LIMit:RBC:LOW?
[:SOURce]:SAFety:STEP<n>:SUB<s>:YDELta:LIMit:RBC:LOW?

It queries the low limit of R2/Rbc in Y/Delta mode for the selected STEP. The unit is Ohm.

[:SOURce]:SAFety:STEP<n>[:MAIN]:YDELta:LIMit:RCA[:HIGH] <numeric value>
[:SOURce]:SAFety:STEP<n>:SUB<s>:YDELta:LIMit:RCA[:HIGH] <numeric value>

It sets the high limit of R3/Rca in Y/Delta mode for the selected STEP. The unit is Ohm.

[:SOURce]:SAFety:STEP<n>[:MAIN]:YDELta:LIMit:RCA[:HIGH]?
[:SOURce]:SAFety:STEP<n>:SUB<s>:YDELta:LIMit:RCA[:HIGH]?

It queries the high limit of R3/Rca in Y/Delta mode for the selected STEP. The unit is Ohm.

**[:SOURce]:SAFety:STEP<n>[:MAIN]:YDELta:LIMit:RCA:LOW <numeric value>
| OFF**

**[:SOURce]:SAFety:STEP<n>:SUB<s>:YDELta:LIMit:RCA:LOW <numeric value>
| OFF**

It sets the low limit of R3/Rca in Y/Delta mode for the selected STEP. The unit is Ohm. The setting of Low limit is turned off when the parameter is set to OFF.

**[:SOURce]:SAFety:STEP<n>[:MAIN]:YDELta:LIMit:RCA:LOW?
[:SOURce]:SAFety:STEP<n>:SUB<s>:YDELta:LIMit:RCA:LOW?**

It queries the low limit of R3/Rca in Y/Delta mode of the selected STEP. The unit is Ohm.

**[:SOURce]:SAFety:STEP<n>[:MAIN]:YDELta:RANGe:UPPer <numeric value>
[:SOURce]:SAFety:STEP<n>:SUB<s>:YDELta:RANGe:UPPer <numeric value>**

It sets the testing resistance range for the selected STEP. The unit is Ohm. The set resistance range will be larger than the inputted resistance.

**[:SOURce]:SAFety:STEP<n>[:MAIN]:YDELta:RANGe:UPPer?
[:SOURce]:SAFety:STEP<n>:SUB<s>:YDELta:RANGe:UPPer?**

It queries the testing resistance range of selected STEP. The unit is Ohm.

**[:SOURce]:SAFety:STEP<n>[:MAIN]:YDELta:RANGe[:LOWer] <numeric value>
[:SOURce]:SAFety:STEP<n>:SUB<s>:YDELta:RANGe[:LOWer] <numeric value>**

It sets the testing resistance range for the selected STEP. The unit is Ohm. The set resistance range will be smaller than the inputted resistance.

**[:SOURce]:SAFety:STEP<n>[:MAIN]:YDELta:RANGe[:LOWer]?
[:SOURce]:SAFety:STEP<n>:SUB<s>:YDELta:RANGe[:LOWer]?**

It queries the testing resistance range of selected STEP. The unit is Ohm.

**[:SOURce]:SAFety:STEP<n>[:MAIN]:YDELta:RANGe:AUTO <boolean> | ON |OFF
[:SOURce]:SAFety:STEP<n>:SUB<s>:YDELta:RANGe:AUTO <boolean> | ON |OFF**

It sets the testing resistance range to auto for the selected STEP.

**[:SOURce]:SAFety:STEP<n>[:MAIN]:YDELta:RANGe:AUTO?
[:SOURce]:SAFety:STEP<n>:SUB<s>:YDELta:RANGe:AUTO?**

It queries if the testing resistance range of selected STEP is set to auto.

**[:SOURce]:SAFety:STEP<n>[:MAIN]:YDELta:TIME:SWITCH <numeric value>
[:SOURce]:SAFety:STEP<n>:SUB<s>:YDELta:TIME:SWITCH <numeric value>**

It sets the SWITCH TIME required for the selected STEP. The unit is second.

**[:SOURce]:SAFety:STEP<n>[:MAIN]:YDELta:TIME:SWITCH?
[:SOURce]:SAFety:STEP<n>:SUB<s>:YDELta:TIME:SWITCH?**

It queries the SWITCH TIME required for the selected STEP. The unit is second.

**[:SOURce]:SAFety:STEP<n>[:MAIN]:YDELta:TIME[:TEST] <numeric value> | OFF
[:SOURce]:SAFety:STEP<n>:SUB<s>:YDELta:TIME[:TEST] <numeric value> | OFF**

It sets the testing time required for the selected STEP. The unit is second. When the parameter is set to OFF, the TEST TIME is turned off.

**[:SOURce]:SAFety:STEP<n>[:MAIN]:YDELta:TIME[:TEST]?
[:SOURce]:SAFety:STEP<n>:SUB<s>:YDELta:TIME[:TEST]?**

It queries the testing time of selected STEP required for testing. The unit is second.

[:SOURce]:SAFety:STEP<n>[:MAIN]:YDELta:TYPE Y | *DELTA*
[:SOURce]:SAFety:STEP<n>:SUB<s>:YDELta:TYPE Y | *DELTA*
It sets the Y/Delta mode test type for the selected STEP.

[:SOURce]:SAFety:STEP<n>[:MAIN]:YDELta:TYPE?
[:SOURce]:SAFety:STEP<n>:SUB<s>:YDELta:TYPE?
It queries the Y/Delta mode test type for the selected STEP.

[:SOURce]:SAFety:STEP<n>:SNUMBER?
It queries the number of sub STEPs for the selected STEP.

7.5.4 SCPI System Status

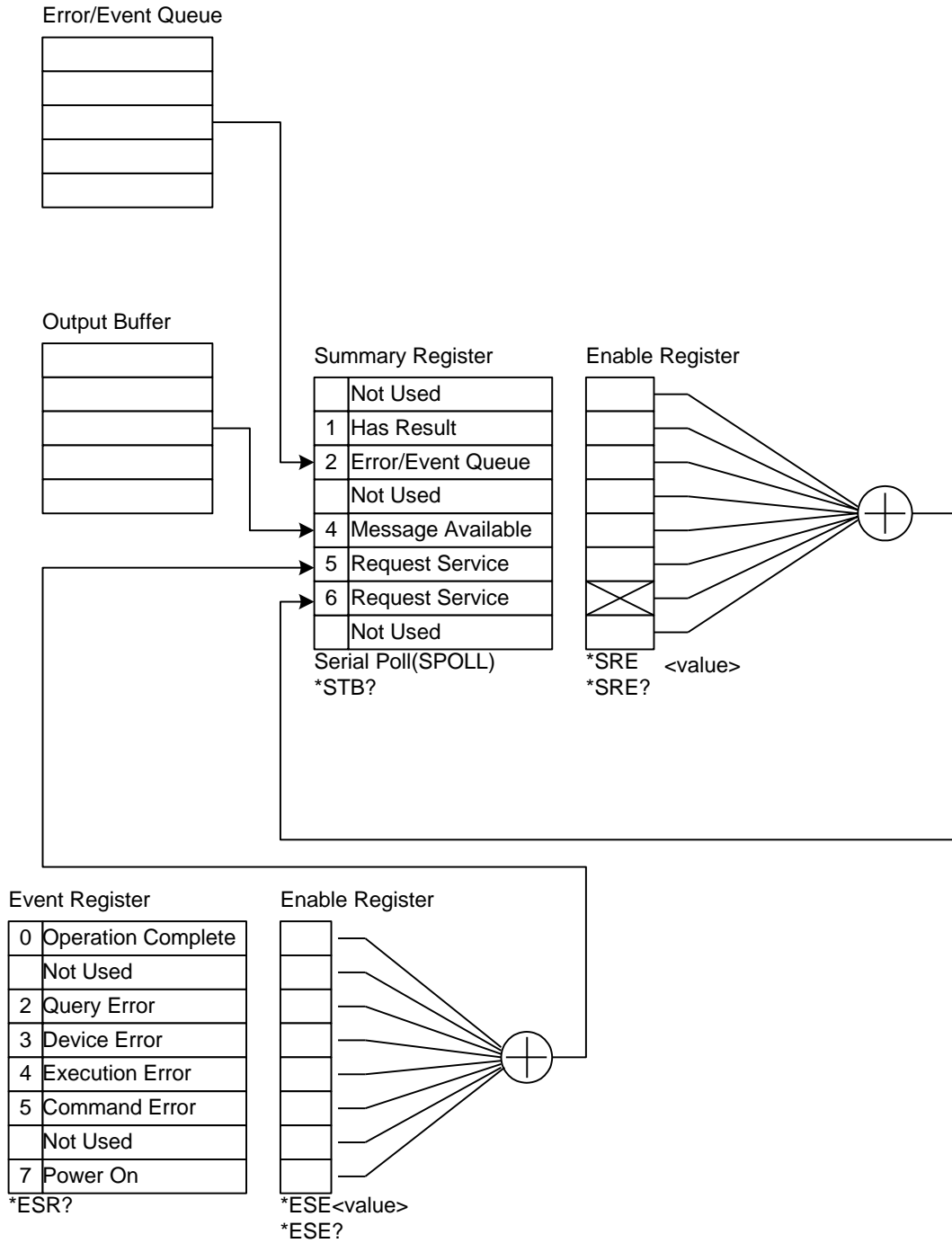

7.6 Error Messages

Notice

- The error messages stored in error queue will be returned in the way of first in first out (FIFO) which means the first error message returned is the first one being saved.
- When error messages exceed 10, the last one be stored in the error queue will be -350 "Queue overflow". It means the error queue is unable to store another error message until the error messages are extracted.
- If no error is generated, +0 "No error" will be stored in the first position of error queue.

-101	Invalid character
-102	Syntax error
-103	Invalid separator
-104	Data type error
-108	Parameter not allowed
-109	Missing parameter
-111	Header separator error
-112	Program mnemonic too long
-113	Undefined header
-114	Header suffix out of range
-120	Numeric data error
-141	Invalid character data
-151	Invalid string data
-158	String data not allowed
-161	Invalid block data
-168	Block data not allowed
-171	Invalid expression error
-178	Expression data not allowed
-200	Execution error
-203	Command protected
-221	Settings conflict
-222	Data out of range
-241	Hardware missing
-250	Mass storage error
-251	Missing mass storage
-256	File name not found
-257	File name error
-292	Referenced name does not exist
-293	Referenced name already exist
-350	Queue overflow
-363	Input buffer overrun
-410	Query INTERRUPTED
-420	Query UNTERMINATED



CHROMA ATE INC.

info@chromaate.com

www.chromaate.com