

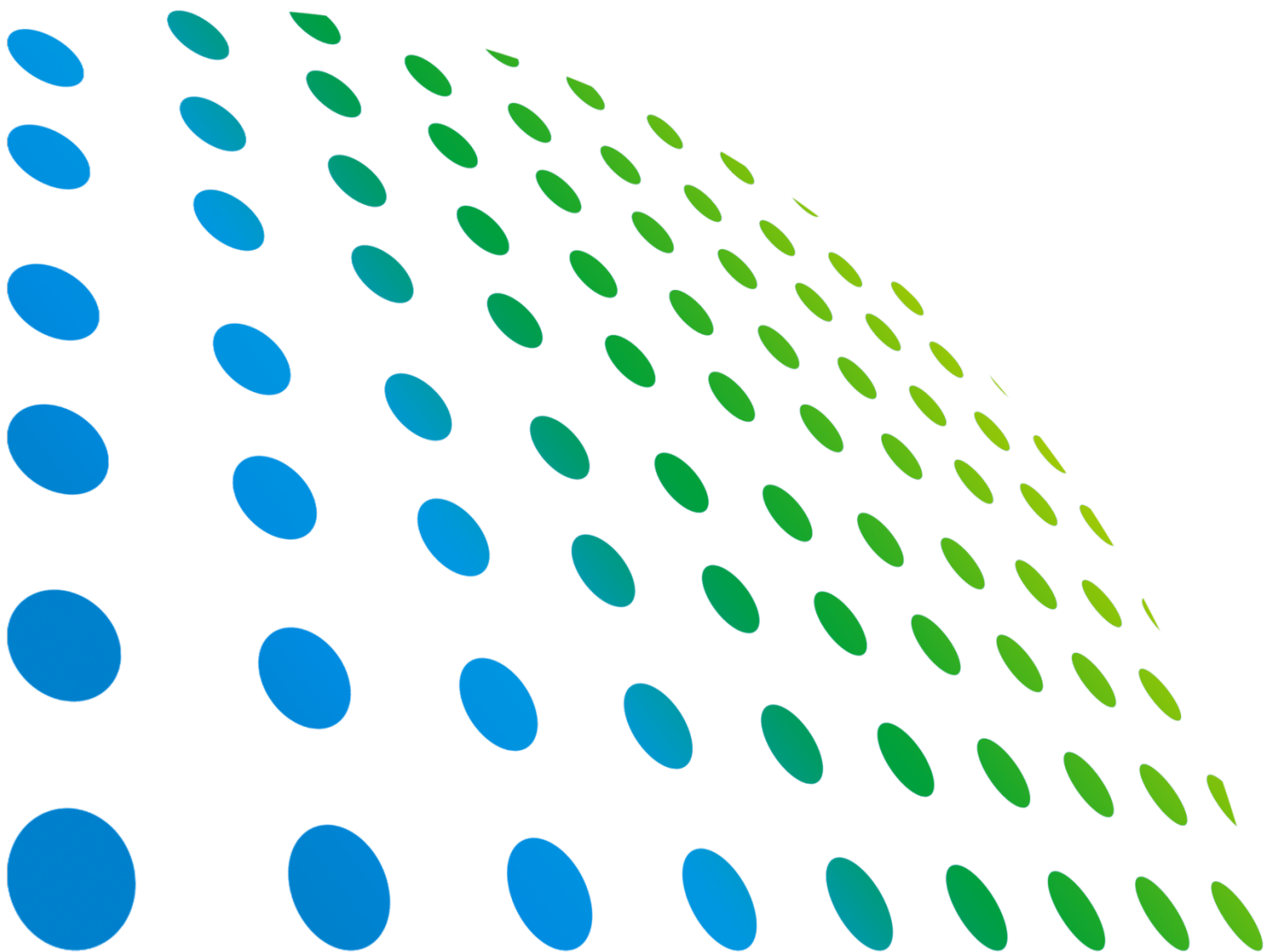

Electrical Safety Analyzer

19032

User's Manual



Electrical Safety Analyzer 19032 User's Manual



Version 2.7
April 2017

Legal Notices

The information in this document is subject to change without notice.

Chroma ATE INC. makes no warranty of any kind with regard to this manual, including, but not limited to, the implied warranties of merchantability and fitness for a particular purpose. Chroma ATE INC. shall not be held liable for errors contained herein or direct, indirect, special, incidental or consequential damages in connection with the furnishing, performance, or use of this material.

CHROMA ATE INC.

66 Huaya 1st Road, Guishan, Taoyuan 33383, Taiwan

Copyright Notices. Copyright 2004 Chroma ATE INC., all rights reserved. Reproduction, adaptation, or translation of this document without prior written permission is prohibited, except as allowed under the copyright laws.

Warranty

All Chroma instruments are warranted against defects in material and workmanship for a period of one year after date of shipment. Chroma agrees to repair or replace any assembly or component found to be defective, under normal use during this period. Chroma's obligation under this warranty is limited solely to repairing any such instrument, which in Chroma's sole opinion proves to be defective within the scope of the warranty when returned to the factory or to an authorized service center. Transportation to the factory or service center is to be prepaid by purchaser. Shipment should not be made without prior authorization by Chroma.

This warranty does not apply to any products repaired or altered by persons not authorized by Chroma, or not in accordance with instructions furnished by Chroma. If the instrument is defective as a result of misuse, improper repair, or abnormal conditions or operations, repairs will be billed at cost.

Chroma assumes no responsibility for its product being used in a hazardous or dangerous manner either alone or in conjunction with other equipment. High voltage used in some instruments may be dangerous if misused. Special disclaimers apply to these instruments. Chroma assumes no liability for secondary charges or consequential damages and in any event, Chroma's liability for breach of warranty under any contract or otherwise, shall not exceed the purchase price of the specific instrument shipped and against which a claim is made.

Any recommendations made by Chroma for use of its products are based upon tests believed to be reliable, but Chroma makes no warranty of the results to be obtained. This warranty is in lieu of all other warranties, expressed or implied, and no representative or person is authorized to represent or assume for Chroma any liability in connection with the sale of our products other than set forth herein.

CHROMA ATE INC.

66 Huaya 1st Road, Guishan, Taoyuan 33383, Taiwan

Tel: 886-3-327-9999

Fax: 886-3-327-8898

e-mail: info@chromaate.com

<http://www.chromaate.com>

Material Contents Declaration

The recycling label shown on the product indicates the Hazardous Substances contained in the product as the table listed below.



<Table 1>

Part Name	Hazardous Substances					
	Lead	Mercury	Cadmium	Hexavalent Chromium	Polybrominated Biphenyls/ Polybromodiphenyl Ethers	Selected Phthalates Group
	Pb	Hg	Cd	Cr ⁶⁺	PBB/PBDE	DEHP/BBP/DBP/DIBP
PCBA	○	○	○	○	○	○
CHASSIS	○	○	○	○	○	○
ACCESSORY	○	○	○	○	○	○
PACKAGE	○	○	○	○	○	○

“○” indicates that the level of the specified chemical substance is less than the threshold level specified in the standards of SJ/T-11363-2006 and EU Directive 2011/65/EU.

“×” indicates that the level of the specified chemical substance exceeds the threshold level specified in the standards of SJ/T-11363-2006 and EU Directive 2011/65/EU.

Remarks: The CE marking on product is a declaration of product compliance with EU Directive 2011/65/EU.

Disposal

Do not dispose of electrical appliances as unsorted municipal waste, use separate collection facilities. Contact your local government for information regarding the collection systems available. If electrical appliances are disposed of in landfills or dumps, hazardous substances can leak into the groundwater and get into the food chain, damaging your health and well-being. When replacing old appliances with new one, the retailer is legally obligated to take back your old appliances for disposal at least for free of charge.



<Table 2>

Part Name	Hazardous Substances					
	Lead	Mercury	Cadmium	Hexavalent Chromium	Polybrominated Biphenyls/ Polybromodiphenyl Ethers	Selected Phthalates Group
	Pb	Hg	Cd	Cr ⁶⁺	PBB/PBDE	DEHP/BBP/DBP/DIBP
PCBA	×	○	○	○	○	○
CHASSIS	×	○	○	○	○	○
ACCESSORY	×	○	○	○	○	○
PACKAGE	○	○	○	○	○	○

“○” indicates that the level of the specified chemical substance is less than the threshold level specified in the standards of SJ/T-11363-2006 and EU Directive 2011/65/EU..

“×” indicates that the level of the specified chemical substance exceeds the threshold level specified in the standards of SJ/T-11363-2006 and EU Directive 2011/65/EU..

1. Chroma is not fully transitioned to lead-free solder assembly at this moment; however, most of the components used are RoHS compliant.
2. The environment-friendly usage period of the product is assumed under the operating environment specified in each product's specification.

Disposal

Do not dispose of electrical appliances as unsorted municipal waste, use separate collection facilities. Contact your local government for information regarding the collection systems available. If electrical appliances are disposed of in landfills or dumps, hazardous substances can leak into the groundwater and get into the food chain, damaging your health and well-being. When replacing old appliances with new one, the retailer is legally obligated to take back your old appliances for disposal at least for free of charge.





Declaration of Conformity

For the following equipment :

Electrical Safety Analyzer

(Product Name/ Trade Name)

19032

(Model Designation)

CHROMA ATE INC.

(Manufacturer Name)

66 Huaya 1st Road, Guishan, Taoyuan 33383, Taiwan

(Manufacturer Address)

Is herewith confirmed to comply with the requirements set out in the Council Directive on the Approximation of the Laws of the Member States relating to Electromagnetic Compatibility (2014/30/EU) and Low Voltage Directive (2014/35/EU). For the evaluation regarding the Directives, the following standards were applied :

EN 61326-1:2013, CISPR 11:2009+A1:2010, EN 61326-2-1:2013

EN 61000-3-2:2006+A1:2009+A2:2009, EN 61000-3-3:2008

IEC 61000-4-2:2008, IEC 61000-4-3:2006+A1:2007+A2:2010,

IEC 61000-4-4:2012, IEC 61000-4-5:2005+corr.October:2009,

IEC 61000-4-6:2013, IEC 61000-4-8:2009, IEC 61000-4-11:2004

EN 61010-1:2010 and EN 61010-2-030:2010

The equipment describe above is in conformity with Directive 2011/65/EU of the European Parliament and of the Council of 8 June 2011 on the restriction of the use of certain hazardous substances in electrical and electronic equipment.

The following importer/manufacturer or authorized representative established within the EUT is responsible for this declaration :

CHROMA ATE INC.

(Company Name)

66 Huaya 1st Road, Guishan, Taoyuan 33383, Taiwan

(Company Address)

Person responsible for this declaration:

Mr. Vincent Wu

(Name, Surname)

T&M BU Vice President

(Position/Title)

Taiwan

(Place)

2017.02.21

(Date)

(Legal Signature)

Safety Summary

The following general safety precautions must be observed during all phases of operation, service, and repair of this instrument. Failure to comply with these precautions or specific WARNINGS given elsewhere in this manual will violate safety standards of design, manufacture, and intended use of the instrument. *Chroma* assumes no liability for the customer's failure to comply with these requirements.



BEFORE APPLYING POWER

Verify that the input power matches the rated input of this equipment.



PROTECTIVE GROUNDING

Connect the protective grounding cables to prevent an electric shock before turning on the power.

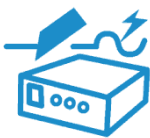

NECESSITY OF PROTECTIVE GROUNDING

Never cut off the internal or external protective grounding wires, or disconnect the wiring of the protective grounding terminal. Doing so will cause a potential shock hazard that may lead to injury or death.



FUSES

Only fuses with the required rated current, voltage, and specified type (normal blow, time delay, etc.) should be used. Do not use repaired fuses or short-circuited fuse holders. To do so could result in a shock or fire hazard.



DO NOT OPERATE IN AN EXPLOSIVE ATMOSPHERE













Do not operate the instrument in the presence of flammable gases or fumes. The instrument should only be used in an environment with good ventilation.



DO NOT REMOVE THE COVER OF THE INSTRUMENT

Operating personnel must not remove the cover of the instrument. Component replacement and internal adjustment can be done only by qualified service personnel.

Safety Symbols

	DANGER – High voltage.
	Explanation: To avoid injury, death of personnel, or damage to the instrument, the operator must refer to the explanation in the instruction manual.
	High temperature: This symbol indicates the temperature is hazardous to human beings. Do not touch it to avoid any personal injury.
	Protective grounding terminal: This symbol indicates that the terminal must be connected to ground before operation of the equipment to protect against electrical shock in case of a fault.
	Functional grounding: To identify an earth (ground) terminal in cases where the protective ground is not explicitly stated. This symbol indicates the power connector does not provide grounding.
	Frame or chassis: To identify a frame or chassis terminal.
	Alternating Current (AC)
	Direct Current (DC) / Alternating Current (AC)
	Direct Current (DC)
	Push-on/Push-off power switch
	The WARNING sign highlights an essential operating or maintenance procedure, practice, condition, statement, etc., which if not strictly observed, could result in injury to, or death of, personnel or long term health hazards. Do not proceed beyond a WARNING sign until the indicated conditions are fully understood and met.
	The CAUTION sign highlights an essential operating or maintenance procedure, practice, condition, statement, etc., which if not strictly observed, could result in damage to, or destruction of, equipment.
	The Notice sign denotes important information in procedures, applications, or areas that require special attention.

Unpacking Inspection

This instrument was inspected before shipment and found to be free of mechanical and electrical defects. As soon as the instrument is unpacked, inspect for any damage that may have occurred in transit. Save all packing materials in case the instrument has to be returned. If damage is found, file a claim with the carrier immediately. Do not return the instrument to Chroma without prior approval.

Standard Package

Item Name	Qty	Description
USA-type power cord	1	90° elbow USA-type power cord; length 1.8m
Power Adapter	1	USA-type power cord 3P – 2P adapter
High Voltage Lead Set	2	Alligator clip – cross HV head, red HV test cable, wire length 1m
Ground Continuity Test Lead Set	1	Alligator clip – banana plug, black HV test cable, wire length 1.2m
GB test cable	1	Cable used for GB test, wire length 1m – Max. 30A (one pair, 2 cables in total).
Power connector test cable	1	Test cable used for connecting power plug; wire length 1.5m.
Power adapter cable	2	Male female adapter cable for power plug test cable.
8A fuse	2	8A SLOW Blow, 110VAC
4A fuse	2	4A SLOW Blow, 240VAC
GB test fixture	1	Test fixture for GB (Ground Bond) zeroing.
Quick Start Guide	2	One English version and one Traditional Chinese version.
User's Manual CD	1	CD for user's manuals in English and Traditional Chinese.

Note | If additional items are required, contact Chroma and provide the item's description.

Hazardous Operating Conditions

1. Do not touch the test area when the analyzer's output is enabled. Electrical shock could result in physical injury or death.

Be sure to observe the following rules:

- Use a standard three prong (grounded) power cord.
- Ensure the earth ground is properly connected.
- Do not touch the output terminal.
- Do not touch the test wire that is connected to the terminal under test.
- Do not touch any unit under test.
- Do not touch any component that is connected to the output terminal for charging.
- Do not touch the test unit right after the test has ended or when the output has just been turned off. It can take several seconds for the high voltage to bleed off.

2. Shock accidents usually occur under the following conditions:

- The earth terminal of the analyzer is not properly connected.
- Insulating gloves are not used during testing.
- Touching the test unit immediately after the test is done.

3. The high voltage output can be remotely controlled via an external control signal. When the analyzer is being remotely controlled, follow the safety guidelines below:

- Determine if this analyzer is under remote control before accessing the test setup as an unexpected high voltage may exist on the DUT (Device Under Test), test cables or probes.
- Do not allow any operator or other personnel to touch the DUT, test cable, or probe output when high voltage is being output from the analyzer.
- Remote control is generally controlled by the high voltage test bar; however, other control circuits can also be used to control it instead. The test bar is the switch for controlling high voltage output, so the connected control wire should not be near the high voltage site and test cable to avoid causing any hazard.

CAUTION

1. Do not bundle or cross the high voltage wire with the RS-232 cable, GPIB control cables, or other low voltage side wires. It could damage the product or PC controller.
2. To avoid fire, heat, and electrical hazards, always check the cable connections of alligator clips and connectors for both COMMON (RTN/LOW) and OUTPUT (High voltage output) terminals before operation to make sure no test cable is loose or damaged.

DANGER



WARNING

1. See Chapter 3 – “*Safety Precautions*”, for safety notes on the proper setup and use of the analyzer.

Storage, Freight, Maintenance, and Cleaning

Storage

When not in use, pack the device properly and store in a suitable environment.

Freight

Pack the device carefully before moving it. If any of the original packing material is missing, use suitable alternative material and mark it “fragile” and “keep away from water” to avoid damaging the product. This product is a piece of precision test equipment; do not drop or hit it.

Maintenance

In case of any malfunction or abnormality, refer to the manual, or contact your local distributor for prompt service. Do not touch any parts inside the instrument to avoid any danger to yourself or damage to the product.

Cleaning

Be sure to unplug the input power cord from the device and remove all other connected wires before cleaning. Use a brush to clean the dust off the machine surface and a low pressure air gun to clean the dust inside the device or send it to your local distributor for cleaning.

Revision History

The following lists the additions, deletions and modifications in this manual at each revision.

Date	Version	Revised Sections
Jan. 2004	1.0	Complete this manual
Feb. 2004	1.1	Modify "Inspection and Examination" "Connecting DUT Methods" "Complete Calibration"
Jan. 2005	1.2	Modify "Inspection and Examination" "Notice Items before Use" "Front Panel" "Remote Command Summary" "Remote Command Description" "Introduction" "OFFSET" "Auto Range" "Start Wait Function" "Each Parameters Setting Description" "Test Procedure" "Test Parameter and Example" "GPIO/RS-232 Operation Description (IEEE-488.2)" Add "Standard Capacitance Value (GET Cs) Description" "OSC Test Procedure"
Sep. 2005	1.3	Modify "Display Area Magnification" and "Simplified Function Flow Chart" in the section of " <i>Front Panel</i> ". Modify the figure 4-3 in the section of " <i>Rear Panel</i> ". Modify the "SYSTEM SETUP" menu and "System parameter setting data description" in the section of " <i>System Parameter Setting</i> ". Modify the "PRESET SETUP" menu and the table "Testing preset parameter function description" in the section of " <i>Simple Setting Wizard</i> ". Modify the figure 4-4 and figure 4-5 in the section of " <i>Auto Range</i> ". Modify the figure 4-6, 4-7, 4-8, 4-9 and 4-10 in the section of " <i>Start Wait Function</i> ". Modify descriptions of "Ground Resistance Test Mode (GB)", "Withstanding Voltage Test Mode (AC)", "Withstanding Voltage Test Mode (DC)", "Insulation Resistance Test Mode (IR)" and "Open/Short Circuit Detection Mode (OSC)" in the section of " <i>Each Parameters Setting Description</i> ". Modify the description of "KEY LOCK setting method" in the section of " <i>KEY LOCK Function</i> ". Modify the figure 4-11 and "Note" in the section of " <i>FAIL LOCK Setting and Using</i> ". Modify the figure 4-16, 4-17, 4-18, 4-19, 4-20, 4-21, 4-22, 4-23 and 4-24 in the section of " <i>Single Test Mode</i> ". Modify the "STEP 1-3" menu in the section of " <i>Auto Mode Setting</i> ". Modify "SCPI Commands" in the section of " <i>Remote Command Summary</i> ". Modify "<item> character data list" in the section of " <i>Remote</i> "

			<i>Command Description</i> .
			Modify "Firmware Update Version" in the section of " <i>Firmware Update</i> ".
			Add the chapter of " <i>The Description of GPIB/RS-232 Interface (IEEE-488.1)</i> ".
Nov. 2006	1.4		Modify <ul style="list-style-type: none"> – the description of Disposal in "<i>Storage, Freight, Maintenance & Disposal</i>". – the description of "Operable range" in the section of "<i>Specifications</i>". – "Figure 3-1" and the description of "Storage" in the section of "<i>Notice Items before Use</i>". – "Figure 4-2" and "Figure 4-3" in the section of "<i>Rear Panel</i>". – the figure of "Test Step" in the section of "<i>Auto Mode Setting</i>". – "25Pin change to 9Pin" in the section of "<i>Cable Wiring Pattern</i>". – Modify the descriptions of RS-232/GPIB command in the section of "<i>Remote Command</i>".
March 2007	1.5		Add the section of " <i>Connector</i> " Add " <i>Material Contents Declaration</i> " Delete the description of Disposal in " <i>Storage, Freight, Maintenance & Disposal</i> ".
Feb. 2008	1.6		Add the following: <ul style="list-style-type: none"> – "EMC" Verification of conformity and "TUV" Test Report. – item 37 to 40 of the table in the section of "<i>IEEE-488.1 Command List</i>". – descriptions of item 6 to 11 in the section of "<i>Description of IEEE-488.1 New Command</i>". Modify the following sections: <ul style="list-style-type: none"> – Standard accessory table in "<i>Inspection and Examination</i>". – description in the section of "<i>An Overview of Product</i>". – description in the section of "<i>Features</i>". – description of "20.Storage" in the section of "<i>Notice Items before Use</i>". – description of item (3), (9) and (10) in the section of "<i>Rear Panel</i>". – "SYSTEM SETUP" screen in the section of "<i>System Parameter Setting</i>". – "PRESET SETUP" screen and description table in the section of "<i>Simple Setting Wizard</i>". – Figure 4-4 and 4-5 in the section of "<i>Auto Range</i>". – Figure 4-6, 4-7, 4-8, 4-9 and 4-10 in the section of "<i>Start Wait Function</i>". – description in the section of "<i>Each Parameters Setting Description</i>". – Figure 4-11 in the section of "<i>FAIL LOCK Setting and Using</i>". – display and description in the section of "<i>Test Parameter and Example</i>". – SCPI command in the section of "<i>Remote Command Summary</i>". – description in the section of "<i>Remote Command Description</i>".

Dec. 2008	1.7	<ul style="list-style-type: none"> – description in the section of <i>“Error Messages”</i>. <p>Add</p> <ul style="list-style-type: none"> – Step Signal of “System parameter setting data table” in the section of <i>“System Parameter Setting”</i>. <p>Modify</p> <ul style="list-style-type: none"> – the description in the section of <i>“Features”</i>. – the description for “PRINT Key” in the section of <i>“Front Panel”</i>. – the descriptions for “GPIB INTERFACE(Option)” and “Plug in SCANNER Insert Hole(Option)” in the section of <i>“Rear Panel”</i>. – the description for ARC LIMIT item of “Parameter settings” in the section of <i>“Single Test Mode”</i>. – “STEP 3: IR Menu” in the section of <i>“Auto Mode Setting”</i>. – the descriptions in the section of <i>“Remote Command”</i>.
Mar. 2010	1.8	<p>Add</p> <ul style="list-style-type: none"> – UL/TUV required descriptions. – LC OFFS GET of “System parameter setting data table” in the section of <i>“System Parameter Setting”</i>. – AC FREQ. of “Withstanding Voltage Test Mode (AC)” in the section of <i>“Each Parameters Setting Description”</i>. <p>Modify</p> <ul style="list-style-type: none"> – Ramp Judg. of “Testing preset parameter function description table” in the section of <i>“Simple Setting Wizard”</i>. – the description in the section of <i>“Single Test Mode”</i>. – the description in the section of <i>“Remote Command Summary”</i>. – the description in the section of <i>“Remote Command Description”</i>. – the description of “-221 Setting conflict” in the section of <i>“Error Messages”</i>. <p>Delete</p> <ul style="list-style-type: none"> – “CHLO” of “Fail Status Description Table” in the section of <i>“GB/AC/DC/IR Test Procedure”</i>.
Jun. 2010	1.9	Add two new items in the chapter of <i>“Precaution before Use”</i> .
Dec. 2010	2.0	Modify <i>“Material Contents Declaration”</i> .
May 2011	2.1	Modify standard package table in <i>“Inspection and Examination”</i> .
Feb. 2012	2.2	Add the section of <i>“Timing Diagram”</i> .
		Modify
		<ul style="list-style-type: none"> – <i>“CE Declaration”</i>. – the description in the section of <i>“Start Wait Function”</i>.
Aug. 2015	2.3	Add the warning to the section of <i>“Hazardous Operating Conditions”</i> .
Dec. 2015	2.4	Modify <i>“Specifications”</i> and <i>“System Parameter Settings”</i> in the chapter of <i>“Description of Panel”</i> .
Aug. 2016	2.5	Replace CE <i>“Declaration of Conformity”</i> .
Jan. 2017	2.6	Remove FAIL related description.
Apr. 2017	2.7	Update CE <i>“Declaration of Conformity”</i> .

Table of Contents

1.	Introduction.....	1-1
1.1	Product Overview	1-1
1.2	Features	1-1
2.	Specifications (18°C~28°C RH ≤ 70%)	2-1
3.	Safety Precautions.....	3-1
4.	Description of Panel	4-1
4.1	Front Panel.....	4-1
4.2	Rear Panel	4-5
4.3	Notes and Procedures before Operating	4-6
4.4	System Parameter Settings	4-7
4.4.1	Hardware/Software AGC	4-9
4.4.2	Discharge-V	4-9
4.4.3	OFFSET	4-9
4.5	Memory Management.....	4-10
4.5.1	Read Memory.....	4-10
4.5.2	Store Memory.....	4-10
4.5.3	Delete Memory	4-11
4.6	Setting Preset Parameter	4-11
4.6.1	Operation Methods.....	4-11
4.6.2	Simple Setting Wizard	4-11
4.6.3	Auto Range	4-13
4.6.4	Start Wait Function	4-14
4.7	GB-Floating Board.....	4-16
4.7.1	Operating Notes	4-16
4.7.2	GB-Floating Description	4-16
4.8	Program Setting	4-17
4.8.1	Operation Methods.....	4-17
4.8.2	Parameters Setting Descriptions	4-17
4.9	How to Process Test.....	4-22
4.9.1	Offset Value Calibration of Test Cable / Fixture.....	4-22
4.9.2	Standard Capacitance Value (GET Cs) Description.....	4-22
4.9.3	DUT Connecting Methods	4-22
4.9.4	Test Procedure	4-23
4.10	CALIBRATION Function	4-24
4.10.1	Enable Calibration	4-24
4.10.2	Clear Memory.....	4-25
4.11	KEY LOCK Function.....	4-25
4.12	User Password Setting	4-26
4.13	FAIL LOCK Function.....	4-26
4.13.1	Setting FAIL LOCK	4-26
4.13.2	Release FAIL LOCK	4-27
4.14	Remote Control	4-27
4.15	Output Signal	4-29
4.16	Timing Diagram	4-30
4.17	Test Parameter and Example	4-31
4.17.1	Single Test Mode.....	4-31
4.17.2	Auto Mode Setting.....	4-35
5.	 GPIB/RS-232 Operation Description (IEEE-488.2)	5-1
5.1	Guide	5-1

5.2	GPIB Interface Specification.....	5-1
5.2.1	Adaptable Standard.....	5-1
5.2.2	Interface Capability.....	5-1
5.2.3	Interface Message.....	5-2
5.2.4	Command Format Descriptions.....	5-2
5.2.5	GPIB Related Panel Descriptions.....	5-2
5.3	RS-232 Interface Specification.....	5-3
5.3.1	Data Format.....	5-3
5.3.2	Command Format Descriptions.....	5-3
5.3.3	Connector.....	5-3
5.3.4	Cable Wiring Pattern.....	5-4
5.4	Remote Commands.....	5-4
5.4.1	Remote Command Summary.....	5-4
5.4.2	Remote Command Description.....	5-10
5.4.3	Start Test by Serial No.....	5-45
5.4.4	SCPI Status System.....	5-46
5.5	Error Messages.....	5-47
5.6	Basic Examples.....	5-48
5.6.1	GPIB.....	5-48
5.6.2	RS-232 Operation Using Basic.....	5-51
6.	Description of GPIB/RS-232 Interface (IEEE-488.1).....	6-1
6.1	Preface.....	6-1
6.2	IEEE-488.1 Command List.....	6-1
6.3	Description of New IEEE-488.1 Commands.....	6-2
7.	Calibration Step.....	7-1
7.1	Calibration.....	7-1
7.2	Voltage Calibration.....	7-2
7.2.1	ACV Calibration.....	7-2
7.2.2	DCV Calibration.....	7-2
7.2.3	IR Voltage Calibration.....	7-2
7.3	Current Calibration.....	7-3
7.3.1	AC Current Calibration.....	7-3
7.3.2	DC Current Calibration.....	7-4
7.4	GBA/GBV Calibration.....	7-5
7.5	Withstanding Voltage Mode Arcing Calibration.....	7-6
7.6	IRA OFFSET Auto Deduction (No DUT Connected).....	7-6
7.7	Insulation Resistance Mode Resistor Calibration.....	7-6
7.8	Complete Calibration.....	7-7
8.	Firmware Update.....	8-1
9.	Maintenance.....	9-1
9.1	General.....	9-1
9.2	Battery Replacement.....	9-1
9.3	Instrument Return.....	9-1

1. Introduction

1.1 Product Overview

This instrument is designed for automatic dielectric withstand voltage (Hipot), insulation resistance, grounding resistance, open/short circuit detection, and dynamic leakage current testing of electromechanical and electronic equipment.

Withstand voltage output power: AC: 200VA (5kV, 40mA). DC: 72VA (6kV, 12mA).

Insulation resistance measurement range: 0.1M Ω ~ 50G Ω . Test voltage range: 50V ~ 1000V.

Grounding resistance measurement range: 0.1 ~ 150m Ω (under 10A the range is extended to 510m Ω .) Output test current range: 1 ~ 30A.

Dynamic leakage current measurement range: 0.01mA ~ 50.0mA (rms). Output test voltage range: 90V ~ 280VAC. (The test rules conform to IEC950, UL544, and UL2601.)

When testing for open/short circuit issues, obtain the standard capacitance value before testing with high voltage. Ensure the DUT is properly connected before beginning a high voltage test.

Display settings include: test mode, status, time, current, voltage, resistance value, and memory number.

The analyzer is equipped with PASS/FAIL logic and provides signal output of testing results and allows remote control operation. The analyzer includes an RS-232 interface (standard), GPIB interface (optional), and SCANNING interface (optional), for connection to automated test systems.

1.2 Features

- AC / DC withstand voltage, insulation / grounding resistance, open/short circuit detection, and dynamic leakage current scan test (option) in one model.
- Simultaneous twin port output.
- Dynamic leakage current simulation compensation.
- Open/short circuit detection.
- Reformation DC quick discharge.
- Follows UL, CSA, TUV, CDE, and CE test rules.
- 0.4ms cut off and 0.2sec discharge rates.
- Keypad lock and material protection function.
- Eight judgment result indication windows.
- Charge current low limit detection function.
- Allows combining a total of 500 test procedures or 100 sets of memory functions.
- GPIB interface (optional).
- Dynamic high voltage leakage current automatic scan function (optional).
- Full-function front panel calibration.

- Bar code scanning can be used to trigger the instrument to start testing.
- Ground Bond Smart Start function.
- Ground Bond with External CT function: 40Ampere, 45Ampere or 60Ampere (optional).

2. Specifications (18°C~28°C RH ≤ 70%)

■ Withstanding Voltage Test (Hipot)									
□ Test Voltage	AC: 0.05 ~ 5kV DC: 0.05 ~ 6kV Constant Voltage								
□ Voltage Regulation	≤ 1%+5V, Rated Load								
□ V-display Accuracy	± (1% of reading + 0.1% of full scale), 2V resolution								
□ Cutoff Current (Note 1)	AC: 0.1mA ~ 40mA DC: 0.01mA ~ 12mA 0.1uA DC resolution								
■ Current Display	<table border="0"> <tr> <td><u>Hi limit setting</u></td> <td><u>Display Range</u></td> </tr> <tr> <td>< 300μA:</td> <td>0.1μA~299.9μA (DC only)</td> </tr> <tr> <td>< 3mA:</td> <td>0.001mA~2.999mA</td> </tr> <tr> <td><40mA AC(12mAdc):</td> <td>0.01mA~40.00mA AC(12.00mAdc)</td> </tr> </table>	<u>Hi limit setting</u>	<u>Display Range</u>	< 300μA:	0.1μA~299.9μA (DC only)	< 3mA:	0.001mA~2.999mA	<40mA AC(12mAdc):	0.01mA~40.00mA AC(12.00mAdc)
<u>Hi limit setting</u>	<u>Display Range</u>								
< 300μA:	0.1μA~299.9μA (DC only)								
< 3mA:	0.001mA~2.999mA								
<40mA AC(12mAdc):	0.01mA~40.00mA AC(12.00mAdc)								
■ Current Accuracy (Note2)	WDC (Withstand DC):: 10.0μA~299.9μA: ±(1% of reading + 0.2% of full scale) 0.299mA~2.999mA: ±(1% of reading + 0.2% of full scale) 2.999mA~12.00mA: ±(1% of reading + 0.45% of full scale) WAC (Withstand AC): 0.100mA~2.999mA: ±(1% of reading + 0.2% of full scale) 2.99mA~40.00mA: ±(1% of reading + 0.13% of full scale)								
□ Output Frequency	50Hz - 600Hz								
□ Test Time	0.3 ~ 999 Sec., Continuous								
□ Ramp Time	0 ~ 999 Sec., Off								
□ Judgment Delay Time	0.3 ~ 99.9 Sec (WDC only)								
■ Arc Detection (Note 3)									
□ Setting Mode	Programmable Setting								
□ Detection Current	AC: 1mA ~ 20mA DC: 1mA ~ 10mA								
□ Min. pulse width	40us 20us 10us 4us approx.								
■ Insulation Resistance Test (Note 4)									
□ Test Voltage	DC: 0.05kV ~ 1kV, Constant Voltage								
□ V-display Accuracy	± (1% of reading + 0.5% of full scale)								
□ Resistance Range	0.1MΩ ~ 50GΩ								
□ Measuring Accuracy	≥ 500V: 1 ~ 1000MΩ: ± (5% of reading + 0.5% of full scale) 1001 ~ 9999MΩ: ±(10% of reading + 0.5% of full scale) 10GΩ ~ 50GΩ: ±(15% of reading + 1% of full scale) < 500V: 0.1 ~ 1000MΩ: ±(10% of reading + 0.5% of full scale) < 100V: 0.1 ~ 1000MΩ: ±(15% of reading + 0.5% of full scale)								
□ Test Time	0.3 ~ 999 Sec., Continuous								
■ Ground Bond Test (Note 5)									
□ Output Current	1.0 ~ 30.00A AC. Constant Current, 0.01A step								
□ Accuracy	± (1% of setting + 1% of full scale) at ≥ 3A								
□ Output Frequency	50Hz, 60Hz								
□ Current Meter	0.00 ~ 30.00A								
□ Accuracy	± (1% of reading + 0.17% of full scale) at ≥ 3A								
□ Resistance Range	0.1 ~ 510.0mΩ (with Offset value)								
□ Accuracy	± (1% of reading + 0.1% of full scale) at ≥10A ± (2% of reading + 1% of full scale) at ≥ 3A(<210mΩ) ± (3% of reading + 2% of full scale) at ≥ 3A(>210mΩ)								

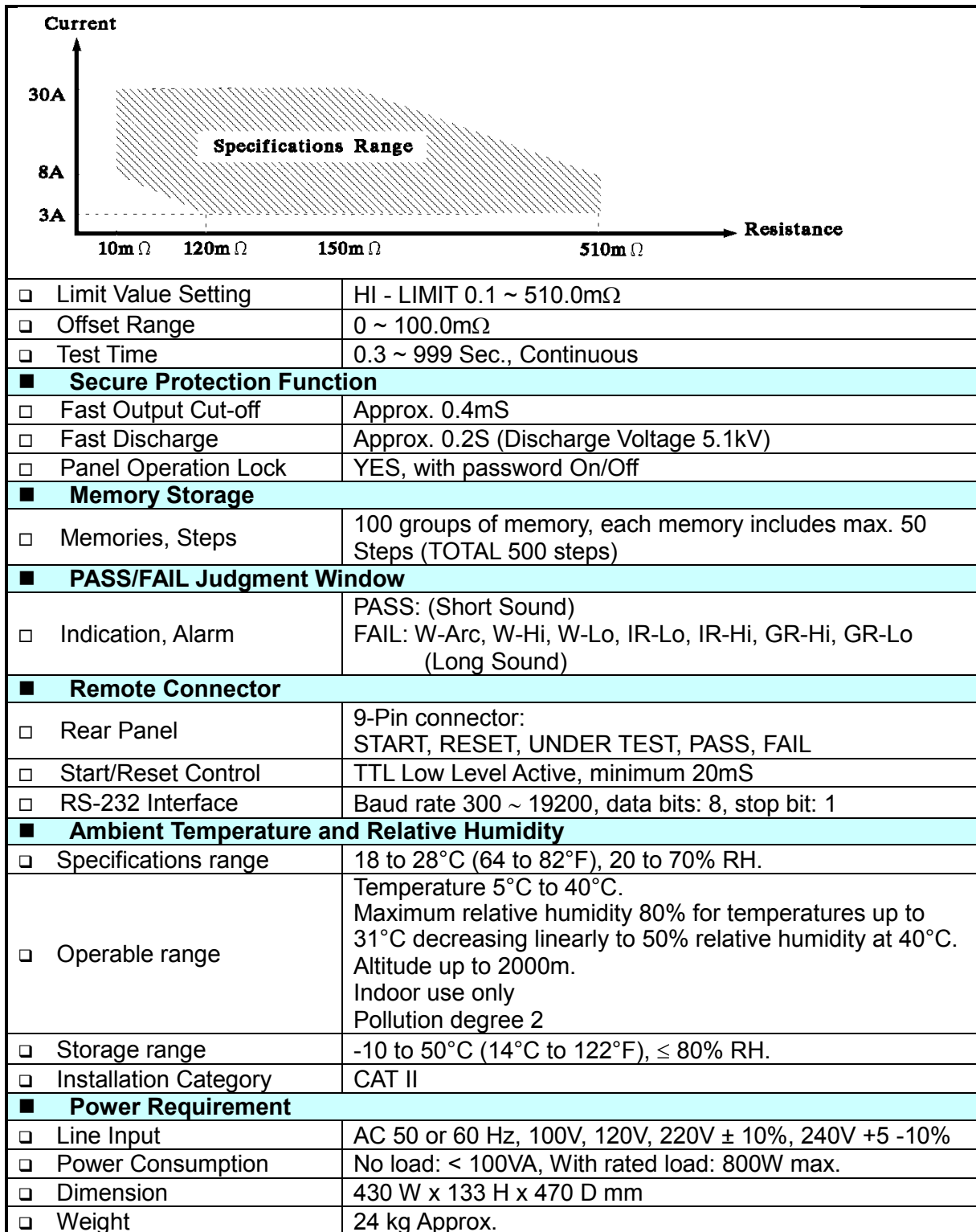

Ground Bond Floating

Rear Panel Output Only	
HV Output (Fixed port 3)	HV output can be set to HV, Low, or Off. Maximum Voltage is 5kVAC, 6kVDC (TUV list is 5kV) Maximum Current is 40mA ac or peak dc WAC maximum add 10 counts extra error WDC maximum add 2 counts extra error
Ground Bond Output (Floating Ground)	Ground Bond can be set to Close or Open (Floating Voltage 1000Vrms or 1400Vpeak AC maximum) Ground Bond Close, the maximum current is 30Amp Maximum (add 2m Ω extra error).

Note

1. Twin Port ON for 20mAac, 6mAdc maximum.
Twin Port ON for less than 1/2 duty cycle output only.
WAC:<1000V, >30mA the max. continuous duty time is 120sec.
WDC:<1000V, >8mA the max. continuous duty time is 120sec
The current resolution is 1.2 count for WAC, and 1.6 count for WDC calculated value.
2. Reference 1.2kV Resistance Load Only.
With standard test lead, to get best accuracy, does not need process OFFSET.
Exceed 1.2kV add 5 counts/kV for WAC mode; add 2 counts/kV for WDC mode.
WDC mode 0mA-0.01mA range, add 5 counts.
WAC mode 0-0.1mA range, add 10 counts.
WAC mode less than 500V add extra 3 counts.
3. Design Specifications
Validation point is 1.25kV with a 250k Ω resistor.
4. 10G Ω ~ 50G Ω without scan unit only.
5. Twin Port ON for 25Amps output maximum.
Twin Port ON for less than 1/2 duty cycle output only.
GB Scanner output, add extra 2m Ω error.
For optimal accuracy, use the standard four-wire type for measuring.
If the Offset is lower than 10m Ω , it is over test specification. Using the Offset can add an extra 5m Ω error.
Electric Strength Test potential for the high voltage terminal was based on circuits in Measurement Category I (CAT I).

3. Safety Precautions

The Electrical Safety Analyzer can provide an output voltage as high as 6000VDC (5000VAC) to the external device under test (DUT). Although the unit is designed with full attention to operator safety, serious hazards could occur if the instrument is used improperly and these safety instructions are not followed.

Never touch the metal of the High Voltage probe directly. Touch only the insulated parts of the lead(s).

Never touch the test leads, test fixture, or DUT in any manner (this includes insulation on all wires and clips) when high voltage is applied and the red DANGER light is ON.

Before turning the unit ON, make sure there is no device (DUT) or fixture connected to the test leads.

After each test, press the [STOP] (red) button for safety. This terminates the high voltage being applied to the output terminals.

When the red DANGER LED is illuminated or flashing, NEVER touch the device under test, the lead wires or the output terminals.

Before touching the test lead wires or output terminals make sure:

- a) The red [STOP] button has been pressed
- b) The red DANGER LED is OFF.

In the case of an emergency, turn OFF the POWER switch using a “hot stick” and disconnect the AC power cord from the wall. DO NOT TOUCH THE INSTRUMENT OR THE DUT.

If the DANGER LED does not go off when the [STOP] button is pressed, immediately stop using the analyzer. It is possible that the output voltage is still being delivered regardless of the TEST ON/OFF control signal.

When the analyzer is used in remote control mode, be extremely careful. The High Voltage Output is being turned On/Off with an external signal.

1. Electric Shock Hazard

To prevent electric shock, all operators should put on insulated rubber gloves before using the instrument.

2. Grounding

Operate the unit with its chassis connected to earth ground. The instrument is shipped with a three-prong power cord to provide this connection to ground. This power cord should only be plugged in to a receptacle that provides earth ground. Serious injury can result if the unit is not connected to earth ground. There is a ground terminal on the rear panel cover of the analyzer. Use the appropriate connector to connect the ground terminal to an actual earth ground. If the instrument is not connected to ground, there may be high voltage on the cover of the analyzer, causing a shock hazard. Make sure to connect the ground terminal to earth, as shown in *Figure 3-1*.

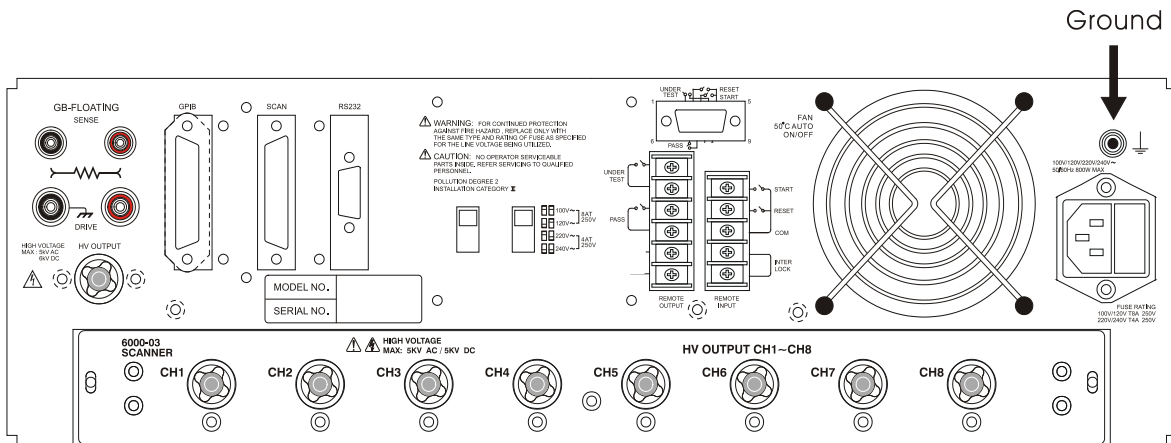

Figure 3-1

3. Connect test cable to COMMON terminal

Tightly connect cable(s) to the (black) DRIVE- terminal, as shown in *Figure 3-2*. If this is not done, the DUT's casing can be charged to the high voltage test level and serious injury or electrical shock hazards could result if the DUT is touched. To connect to the DUT with this cable, connect the test cable to the COMMON terminal before connecting it to the DUT.

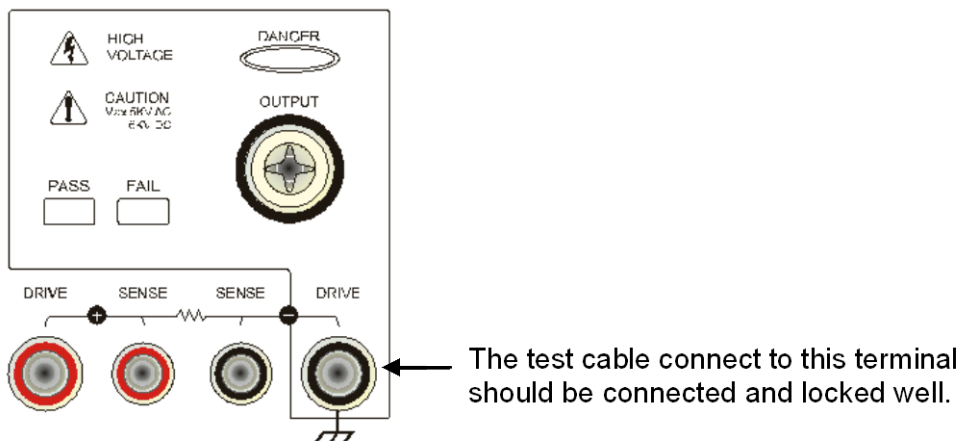

Figure 3-2

4. Connect test cable to High Voltage output terminal

After the COMMON test cable has been connected, follow the steps below to connect the high voltage output cable:

- Press the [STOP] key.
- Confirm the DANGER indicator LED is not illuminated.
- Short the COMMON terminal with the high voltage output terminal; confirm there is no voltage output.
- Plug the high voltage test cable into the high voltage output terminal.
- Connect the COMMON test cable to the DUT first, and then connect the high voltage test cable to the DUT.

5. Test stop

When the test is over or the analyzer is not running or needs to be shut down, turn the power switch OFF (0) as shown in *Figure 3-3*.

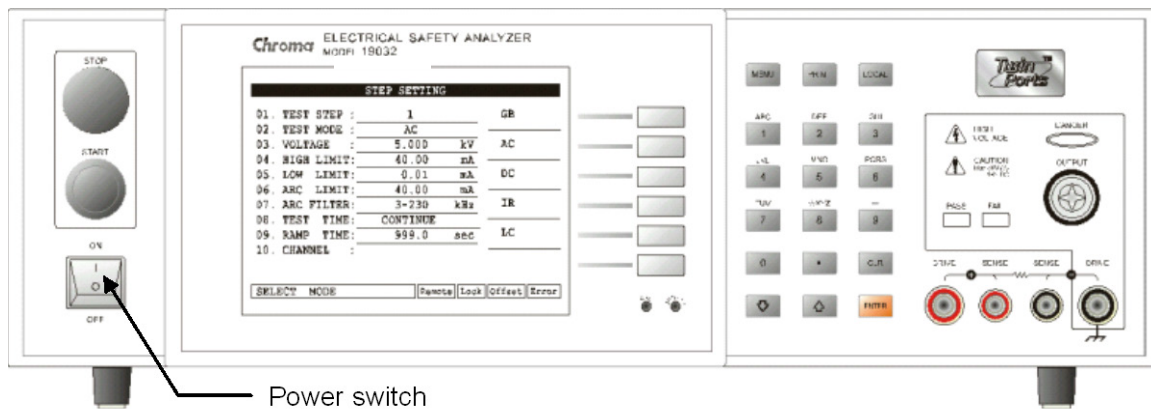

Figure 3-3

6. Dangerous areas during a test

It is very dangerous to touch any high voltage area while a test is running. Do not touch the DUT, test cable, probe, or output terminal.



WARNING Do not touch the alligator clips on the test cable when the analyzer is running a test. The insulation of the plastic layer is not enough to prevent a shock hazard (See Figure 3-4.)

Do not touch here when high voltage is present.

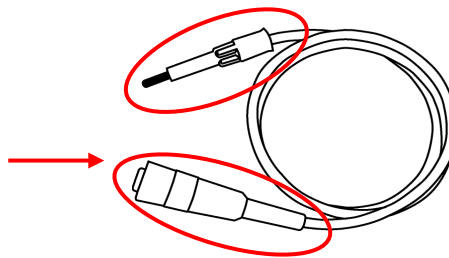

Figure 3-4



WARNING High voltage may be present for a period of time after the power has been turned off.

7. Test complete confirmation

Follow the steps below BEFORE touching the DUT, high voltage test cable, or output terminal areas when modifying the circuit under test conditions or upon test completion:

- Ensure the power switch is turned off.
- The DUT will have high voltage on it when the insulation resistance test is run.

Be sure to follow the steps in items 8 and 9.



WARNING High Voltage is present when testing insulation resistance.

8. Charge on DUT during insulation resistance test

When the insulation resistance test is run, the DUT, capacitor, test cable, probe, and output terminal have high voltage on them. After turning off the power switch, the test system needs a period of time to discharge. DO NOT touch any test area that may cause shock immediately after the power has been turned off.

9. Confirm charging voltage has been completely discharged

The discharge time depends on the testing voltage and DUT characteristics. Assume that the high voltage on the DUT is equivalent to the high voltage on a 0.01uF capacitor in parallel with a 100MΩ resistance circuit. After turning off the power, the voltage on the DUT will decrease to lower than 30V in approximately 3.5 seconds. When the test voltage is 500V it takes approximately 2.8 seconds. To calculate the time required for the voltage to decrease below 30V, use the formula below. (Refer to *Figure 3-5*.)

$$\text{Formula: } V_0 e^{-t/RC} = V_{IL}$$

$$\text{Ex.: } 1000V \times e^{-t/RC} = 30V$$

$$e^{-t/RC} = 0.03$$

$$-t/RC = \ln 0.03 \quad \therefore t = 3.5 \text{ Sec}$$

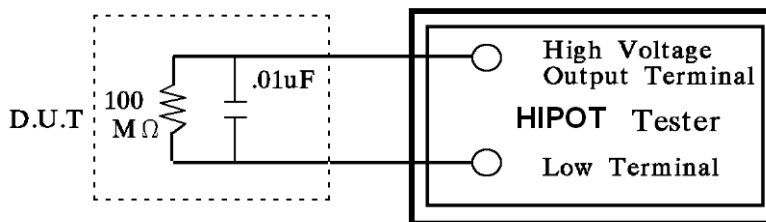

Figure 3-5

10. Remote control of the analyzer

This instrument allows remote control of the high voltage output by an external control signal. To prevent shock hazards, observe the following rules:

- Do not allow any unexpected high voltage output that may be dangerous.
- When the analyzer is putting out high voltage, do not permit the operator or other personnel to contact the DUT, test cable, or probe output terminal.

11. Turning the power switch on and off

The analyzer should be positioned so that the power switch can be easily reached by the operator during an emergency. When the power switch is turned off, wait a few seconds before turning it back on. Do not turn it on and off continuously, especially during high voltage output. **Do not connect any object to the high voltage output terminal when switching the power on or off.**

12. Other safety items

Ensure the cover of the analyzer has been connected to earth ground before the high voltage output terminal is short-circuited with the COMMON terminal.

13. Handling a dangerous event

Under any hazardous situation, such as shock, the DUT is burning, or the analyzer is burning, follow the steps below to remove the danger:

- In the case of an emergency, turn OFF the POWER switch using a “hot stick” and disconnect the AC power cord from the wall. **DO NOT TOUCH THE INSTRUMENT OR THE DUT.**

14. Instrument Problems

The following is a very dangerous situation. If this condition occurs, turn off power and remove the AC power plug immediately. Do not use the instrument; send it back to Chroma for repair.

- If the DANGER LED does not go off when the [STOP] button is pressed, immediately stop using the analyzer. It is possible that the output voltage is still being delivered regardless of the TEST ON/OFF control signal.

15. DANGER LED error

When the [START] key is pressed, if there is already a reading on the voltage meter and the DANGER LED is not illuminated, turn the analyzer off immediately. Return the unit to Chroma ATE for repair.

16. Running the analyzer for an extended period of time.

Check the ambient temperature when running the ‘withstand voltage test’. If the high limit setting value is 20.00mA, stop the test if the ambient temperature goes higher than 40°C, and wait until it cools down to normal temperature before resuming the test.

17. Select the proper AC INPUT power setting.

Set the voltage selection switch on the rear panel to the correct position according to the local power. Before plugging in the power cable, make sure the input AC power scale is the same as the rear panel switch power setting. Make sure the proper fuse is installed. See the following table for the correct voltage setting and fuse to be used:

Scale	Nominal Value	Range	Fuse
100	100V	90V ~ 110V	8A Slow/250V
120	120V	110V ~ 130V	8A Slow/250V
220	220V	200V ~ 240V	4A Slow/250V
240	240V	220V ~ 250V	4A Slow/250V

Make sure the correct fuse/voltage combination is used. Replace the fuse only after the power has been disconnected. Remove the fuse stand from the power socket and press the new fuse into the fuse stand, then plug in the power socket.

 **CAUTION** : Use the correct fuse when replacing the fuse. Failure to do so may result in a hazardous situation.

18. Unstable AC power.

If the AC power is unstable within the selected voltage range it may cause the unit to malfunction. If necessary, use a power stabilizer to correct the situation.

19. Analyzer drawing maximum current.

When the DUT is drawing maximum current before a fail judgment is made, it may continue to draw the maximum current (about ten amperes) up to ten milliseconds before shutdown.

20. Storage

The unit normally operates in a temperature/humidity range of 5°C ~ 40°C, 80% RH. Operating outside of this range may cause a malfunction. The unit storage temperature/humidity range is -10°C ~ 50°C, 80% RH. If the unit will not be used for a long time, store it in the original packing material. Keep the unit from direct sunlight, high temperature, vibration, humidity, or dusty places.

21. Warm up

The analyzer unit should be warmed-up for 15 minutes prior to use and 30 minutes prior to calibration.

22. Warning signal during testing

“DANGER – HIGH VOLTAGE TEST IN PROGRESS, UNAUTHORIZED PERSONS KEEP AWAY”

23. TWIN PORT

The unit process twin port measurement mode with AC withstand, DC withstand, or IR (insulation impedance) on GB (grounding impedance). When processing the maximum AC or DC output current in this measurement mode, do not exceed 1/2 the maximum specification on a continuous basis.

24. Description of ground bond lead wiring

The maximum output current of this unit is 30A AC. A loose cable connection may cause a temperature rise and the ground bond output terminal may be damaged.

Follow the steps below to ensure a good wiring connection:

- Remove both the DRIVE+ (red) and DRIVE- (black) caps.
- Use a hex box spanner to loosen both nuts and then remove the nuts.
- Slip the test leads onto both terminals.
- Install the nuts and use a hex box spanner to tighten both nuts.
- Re-install both the DRIVE+ (red) and DRIVE- (black) caps.
- Tighten both caps.
- The correct Ground Bond lead wiring is shown below:

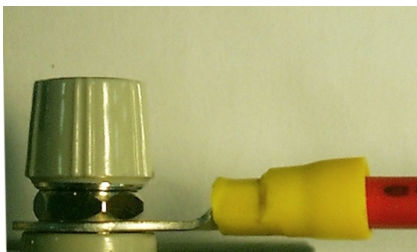

25. Keep test cable away from the panel

Keep the high voltage cable and the DUT away from the panel at least 30 cm during operation to avoid display interference caused by high-voltage discharge.

26. Connecting automated devices

- Connect the grounds of the device and the automated station together.
- Add an anti-interference iron core to the high voltage cable and the 2 ends (device output and DUT) of the RTN/LOW test cable with a minimum of one turn of wire through the core.
- The high voltage and RTN/LOW test cables must be separated from the control cable.

4. Description of Panel

4.1 Front Panel

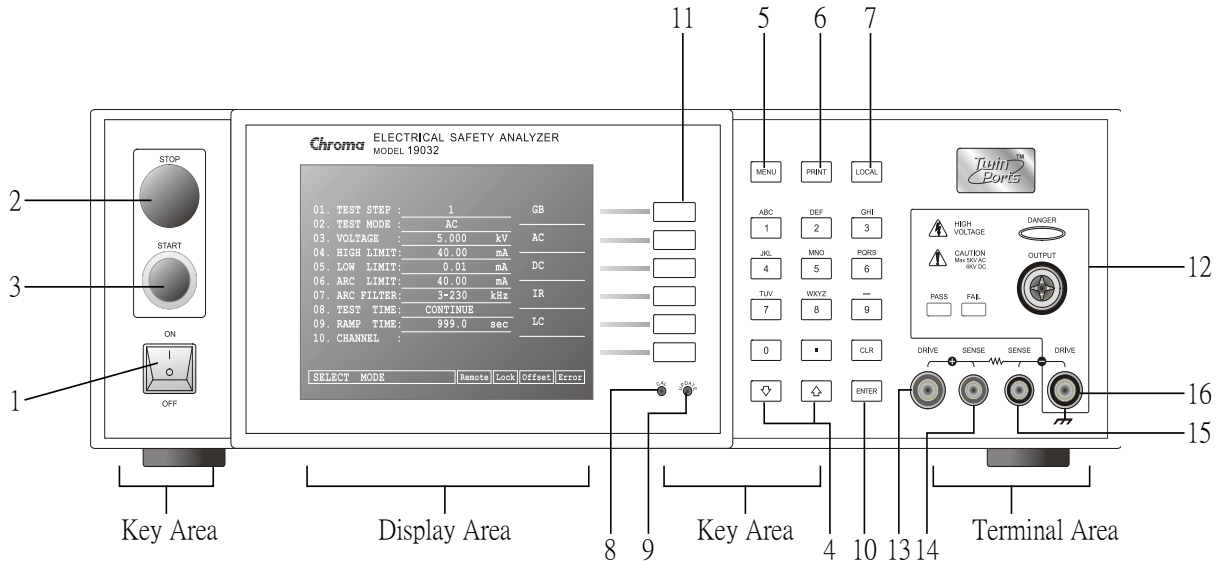
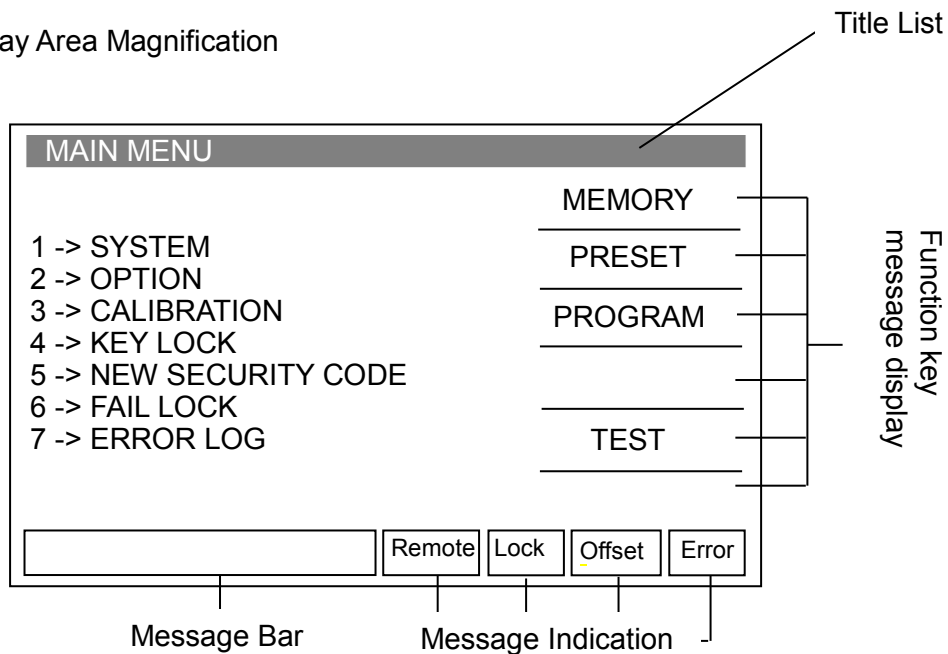

Figure 4-1

Figure 4-1 illustrates the controls and indicators on the front panel of the Electrical Safety Analyzer.

■ Display Area Magnification



Display Area

Title List: This list displays the current setting of the analyzer or testing mode.

Function Key Message Display area:

Different function descriptions are displayed for each of the different menus. The right side of the display shows the corresponding Function Keys. If the description is blank or gray scale font, the corresponding function is invalid.

Message Bar: This list displays the setting mode, the range of the setting value, and the testing time.

Message Indication Diagram:

Remote: When this area is highlighted, the analyzer is under remote control (the analyzer is being controlled by a PC through either the RS-232 or GPIB interfaces connected to the PC). At the same time, all of the keys are disabled except for the [STOP] and [LOCAL] keys.

Lock: When this area is highlighted, the analyzer is in parameter-protected mode. All other keys are disabled except for "MEMORY", "TEST", "KEY LOCK", and "ERROR LOG" modes.

Offset: When this area is highlighted, the analyzer has zeroed the leakage current of test cables and test leads.

Error: When this area is highlighted, an error message has been received.

Simplified Function Flow Chart

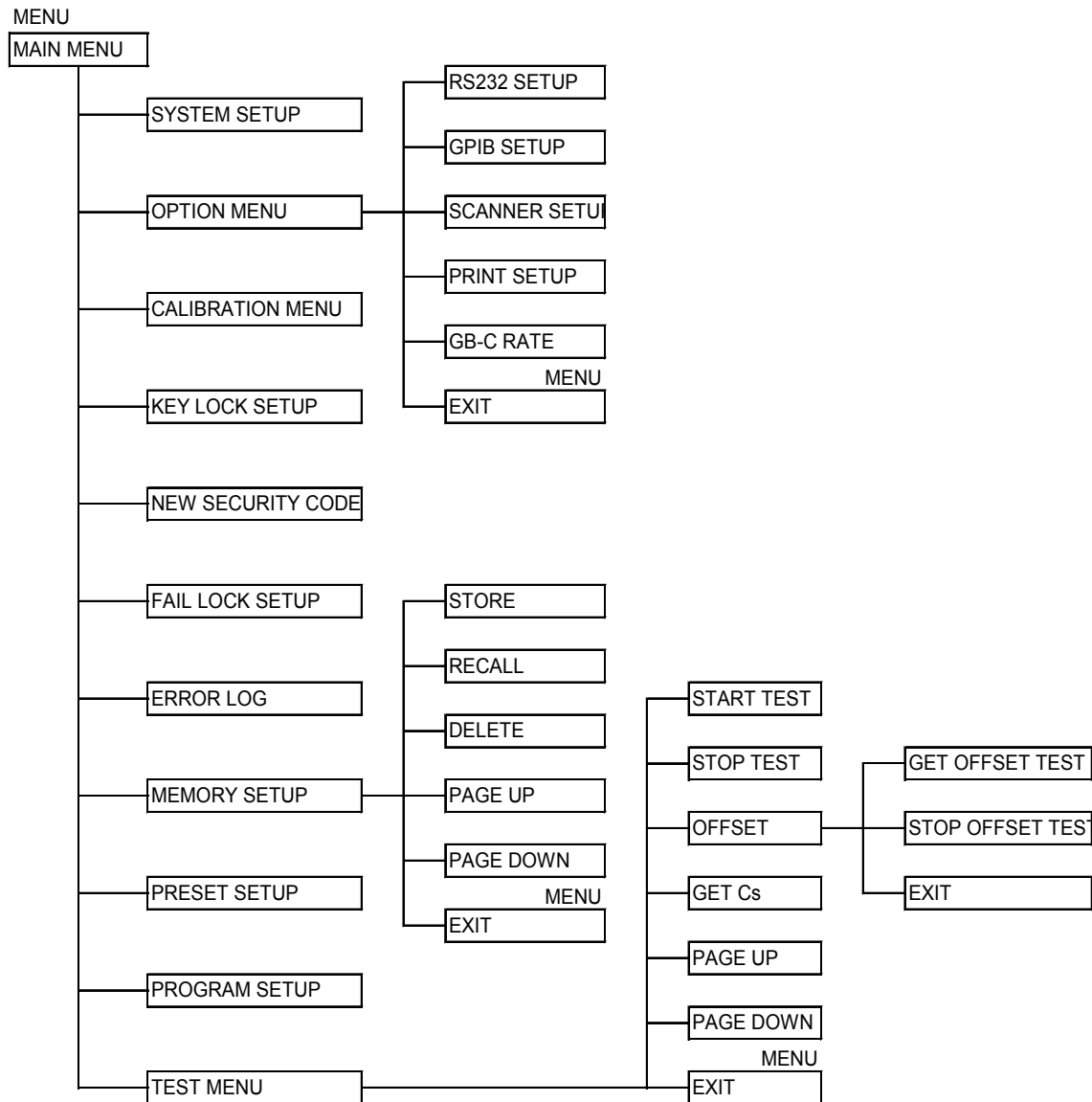

Key Area

(1) Power Switch: This switch turns on AC power to the analyzer. Before starting, read *Chapter 3 "Safety Precautions"*.

(2) STOP Key: Stops the test in progress.

(3) START Key: Starts a test and applies high voltage to the Test Terminals.

(4) Cursor Keys: [Δ], [∇] keys to move highlighted cursors.

(5) MENU Key: Under each main display mode, press this key to return to "MAIN MENU" mode.

(6) PRINT Key: This key is disabled.

(7) LOCAL Key: In REMOTE status, pressing [LOCAL] returns the analyzer to LOCAL mode.

- (8) **Cal-Enable:** Calibration switch. Used by qualified service personnel for unit calibration. Should NOT be used by any other operator.
- (9) **Update:** Update firmware switch. Used by qualified service personnel for unit service. Should NOT be used by any other operator.
- (10) **Data Entry Keys/Program Key**
- [0][.] ~ [9]:** Numeric key/character key, for inputting test parameter data (numeral or alphabet). Under "MAIN MENU" display mode, [1], [2], [3], [4], [5] keys can enter each display mode.
 - [ENTER]:** Enter key. After entering a test parameter, press this key to confirm entry.
 - [CLR]:** Clear key. If an error is made when entering a test parameter, press this key to cancel the input.
- (11) **Function Keys:** Function Key. Selects sub-menus and enters test parameters. If the description is blank, the corresponding function is invalid.

Terminal Area

- (12) **OUTPUT:** High Voltage Terminal (AC/DC Hipot & IR).
This terminal has a high electric potential output. Do not touch when the DANGER LED is illuminated.
- (13) **DRIVE (+):** High Current Terminal (Driver) for Ground Bond Test.
- (14) **SENSE (+):** High Voltage Terminal (Sense) for Ground Bond Test
- (15) **SENSE (-):** Low Voltage Terminal (Sense) for Ground Bond Test.
- (16) **DRIVE (-):** Ground Reference for ALL Tests.
This terminal is the high voltage test and reference terminal ground (low electric potential terminal).

4.2 Rear Panel

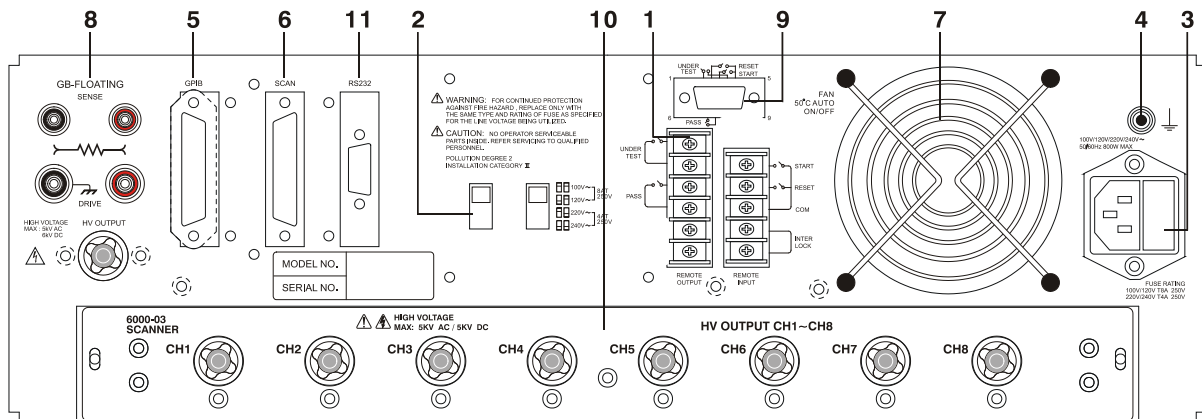

Figure 4-2

- (1) **REMOTE I/O:** The test result signal input/output terminals.
START: Start test signal input terminal.
RESET: Stop test signal input terminal.
INTER LOCK: HV can only be enabled when the two terminals are shorted together.
UNDER TEST: When the analyzer is running a test the output terminal relay contacts will close. The relay contacts can support 115V AC, <0.3A. The test runs until the RESET signal is received.
PASS: When the analyzer determines the DUT passed the test the output terminal relay contacts will close. The relay contacts can support 115V AC, <0.3A. The signal remains until the RESET signal is received.

(2) VOLTAGE SELECTOR Input Power Supply Range Switch

This test instrument supports the following input power voltage ranges:

- 100V adaptable voltage range 90~110V AC
- 120V adaptable voltage range 100~130V AC
- 220V adaptable voltage range 200~240V AC
- 240V adaptable voltage range 220~250V AC

If the voltage range is changed, be sure to change the fuse at the same time.

- (3) **AC LINE:** AC power socket and fuse holder.
 3-wire connection for AC power source. Fuse drawer: 8A 250V for 100-120 operation, 4A 250V for 220-240 operation.
- (4) **GND TERMINAL:** Safety GND terminal. Connect this terminal to earth ground. If this terminal is not grounded, high voltage may exist on the cover, resulting in a safety hazard.
- (5) **GPIB INTERFACE (Option):**
 This socket is for an optional GPIB interface (IEEE-488-1978). Refer to “Chapter 5 – GPIB/RS-232 Operation Description (IEEE-488.2)” in this manual for a detailed description.
- (6) **SCAN INTERFACE:**
 This interface connects with the 9030A Scanning Box (Option).

(7) **FAN:** Temperature control fan. When the temperature exceeds 50°C, the fan turns ON. When the temperature is less than 45°C, the fan turns OFF.

(8) **REAR PANEL GB OUTPUT Terminal**
This terminal Floating status is selectable, that is open-circuited with front panel GB terminal.

(9) **9 Pin D Connector**
All of the 9 pin D-Sub connector functions are the same as (1) Remote I/O.

(10) **Plug in SCANNER (Option):**

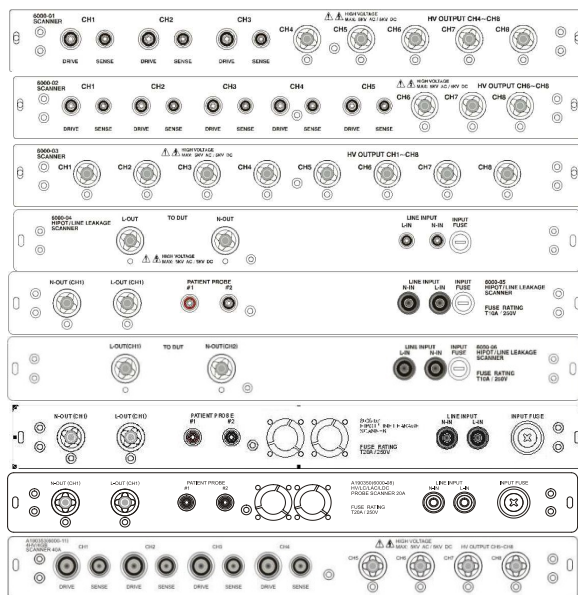

Option (6000-01): 5 points of HV output & 3 (UL approval) sets of grounding terminals.
Option (6000-02): 3 points of HV output & 5 (UL approval) sets of grounding terminals.
Option (6000-03): 8 points of HV output. (UL approval)
Option (6000-04): HV / LC scanner
Option (6000-05): HV / LC scanner with probe
Option (6000-06): L-N Scanner & Leakage Current Scanner
Option (6000-07): HV / LC scanner with probe 20A
Option (6000-08): HV / LC / LAC / LDC probe scanner 20A
Option (6000-11): 4 HV output & 4 sets of grounding terminals

Figure 4-3

(11) **RS-232 INTERFACE:**
RS-232 interface. (GPIB and RS-232 interface cannot be used simultaneously.)

4.3 Notes and Procedures before Operating

1. Before plugging in the AC power cable, ensure the fuse and voltage selector settings match the power source being used.
2. Before turning on power, read *Chapter 3 "Safety Precautions"*.
3. When the power is turned on, the analyzer will automatically perform a self-test. If the self-test indicates there is a problem, turn off the power switch and remove the power cord.

4.4 System Parameter Settings

Entering Data:

1. When title shows "SYSTEM SETUP", press the [△], [▽] keys to move the highlighted cursor to the parameter to be set.
2. Press the numeric/character key or Function Key to select the parameter data.
3. If the cursor is blinking, parameter data entry has not been completed. If an error is made when entering data, press [CLR] to clear and enter again. Press [ENTER] to save the parameter data.

SYSTEM SETUP			
01. Contrast	:	17	UP
02. Beeper Vol.	:	HIGH	
03. Compensate	:	20%	
04. DC 50V AGC	:	OFF	
05. Discharg-V	:	3.6kV	DOWN
06. Pass ON	:	CONTINUE	
07. Use Source	:	OFF	
08. After Fail	:	RESTART	
09. AC OFFSET	:	0.10mA	
10. LC OFFSET	:	0.00mA	
11. IEEE-488.1	:	OFF	
1-31 Remote Lock Offset Error			

System parameter setting data descriptions:

Setting Item	Range	Initial Setting	Description
Contrast	1~31	17	Adjust LCD brightness
Beeper Volume	HIGH/MEDIUM/LOW/OFF	HIGH	Adjust the buzzer volume
Compensate	5% - 50%	20%	LC input voltage compensation
DC 50V AGC	ON/OFF	ON	Hardware compensation for voltage over 50VDC
Discharg-V	0.05-5.1KV	3.60KV	DC discharge setting
Pass ON	0.1~99.9s, CONTINUE	CONTINUE	Length of time the PASS signal on the REMOTE terminal on the rear panel will remain active after a successful test of the DUT
Use Source	ON/OFF	OFF	When the 6000-04~6000-8 scanner is installed on 19032, it can set the connected AC Source output voltage and frequency (6000-04~6000-08) in LC Mode if Use Source is set to ON. Note : The models of AC Source can be connected are CHROMA 615XX /616XX /64XX.
After Fail	CONTINUE/RESTART/STOP	RESTART	(1) When set to CONTINUE, if any test STEPs fail, the test will continue until all STEPs are completed. (2) When set to RESTART, if any test STEPs fail, press START to restart the test.

			(3) When set to STOP, if any test STEPs fail, press STOP , then press START to restart the test.
AC OFFSET	0 ~ 2.5mA	0.10mA	(1) When Offset value is higher than AC OFFSET value, Current reading = Current real measurement value – Offset value. (2) When Offset value is lower than AC OFFSET value, Current value $= \sqrt{(\text{Real measurement value})^2 - (\text{Offset})^2}$
LC OFFSET	0 ~ 2.5mA	0.00mA	(1) When Offset value is higher than LC OFFSET value, Current reading = Current real measurement value – Offset value. (2) When Offset value is lower than LC OFFSET value, Current reading = $\sqrt{(\text{Real measurement value})^2 - (\text{Offset})^2}$
IEEE-488.1	ON/OFF	OFF	(1) When set to ON, GPIB/RS-232 command format is IEEE-488.1 (compatible with 9032C). (2) When set to OFF, GPIB/RS-232 command format is IEEE-488.2.
Step Signal	ON/OFF	OFF	(1) When Step Signal is set to ON, the signals on the rear panel are as follows: 1. UNDER TEST = EOT 2. PASS = EOS 3. FAIL = PASS/FAIL (when the signal is PASS, RELAY OPEN. When the signal is FAIL, RELAY CLOSE.) (2) When Step Signal is OFF, the signals of UNDER TEST, PASS and FAIL on rear panel follows the original definition. Note : When the Step Signal is ON, the PASS setting is disabled since the PASS signal changes to EOS.
LC OFFS GET	ON/OFF	ON	(1) When set to ON, LC Mode will be included when performing OFFSET GET. (2) When set to OFF, LC Mode will not be included when performing OFFSET GET.

4.4.1 Hardware/Software AGC

The AGC function helps stabilize the output voltage when it is affected by the load.

ACV : 50V~5KV (Hardware AGC is always ON. Software AGC initial setting is ON; can be set to OFF.)

DCV : 50V~499V (Hardware AGC initial setting is ON, can be set to OFF. Software AGC initial setting is ON; can be set to OFF.)

DCV : 500V~6KV (Hardware AGC is always ON, software AGC initial setting is ON; can be set to OFF.)

IR : 50V~1KV (No hardware AGC, software AGC initial setting is ON; can be set to OFF.)

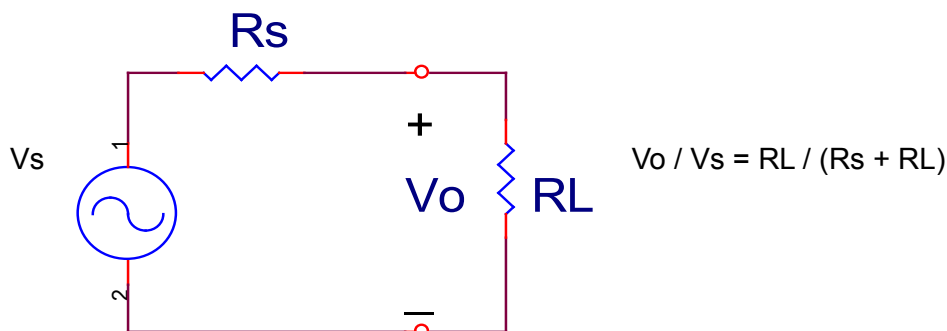

1. Hardware AGC: when $V_o < V_s$ due to a load affect, the hardware AGC circuit will equalize the voltage within 0.1sec.
2. Software AGC: This analyzer uses software AGC under DC 50V-500V and IR 50V-1000V. Software compensation is slower than hardware compensation so it does not cause a voltage shock to the DUT. The general IR R_L is larger than the R_s of the analyzer, so $V_o \sim V_s$.

4.4.2 Discharge-V

Discharge-V: The discharge function permits the user to set the value of the voltage that the instrument will discharge to upon completion of a test. The range is 0.05kV to 5.10kV (the default value is 3.6kV). The time it will take to discharge to a specific voltage is dependent on the capacitance of the DUT. The discharge time is a natural log function. When the voltage drops below the Discharg-V setting, the voltage will be discharged to 0V in 0.2sec.

4.4.3 OFFSET

1. DC OFFSET: Before testing WDC mode, connects test cable first. After the fixture is tested, then processes OFFSET for ensure test value accuracy. The current calculation formula: Current reading = Current real measurement value – Offset value.
2. AC OFFSET: Before testing WAC mode, connects test cable first. After the fixture is tested, then processes OFFSET for ensure test value accuracy. Especially when test voltage is higher and leakage current of test fixture and instrument is more increase. The happened of Offset current is often caused by capacitance feature. According to mathematics, when test a resistive load, its' current value =

$\sqrt{(\text{Resistance load value})^2 + (\text{Offset})^2}$. Therefore, when measured out resistive load current value, current reading = $\sqrt{(\text{Real measurement value})^2 - (\text{Offset})^2}$. When tests a capacitive load, current reading = (real measurement value) – (Offset).

3. LC OFFSET: Before testing dynamic leakage current mode, connects test cable first. After the fixture is tested, then processes OFFSET for ensure test value accuracy especially when measures small current. The leakage current of general test fixture, isolation transformer and the instrument are mostly caused by capacitance feature. According to mathematics, when test a resistive load, its' current value = $\sqrt{(\text{Resistance load value})^2 + (\text{Offset})^2}$. Therefore, when measured out resistive load current value, current reading = $\sqrt{(\text{Real measurement value})^2 - (\text{Offset})^2}$. When tests a capacitive load, current reading = (real measurement value) – (Offset).
4. GB OFFSET: use the standard 4-wires test cable to process standard resistance test, doesn't need additional OFFSET operation. If using with our grounding accessories, the maximum test error is possible increased to 2mohm. Before Offset test is done, be sure offset resistance. When Offset resistance value is lower than 5mohm, do Offset is not recommended. Incorrect Offset may influence error of real test value.
5. OSC OFFSET: There is stray capacitance on wire or fixture, does OFFSET elimination again on changing wire or fixture every time for ensure the accuracy of testing.

4.5 Memory Management

When the title displays "MAIN MENU", press the [MEMORY] Function Key. The title will display "MEMORY SETUP". The memory can be read, stored or deleted. Each memory location includes the test parameter, test preset parameter, and memory name.

4.5.1 Read Memory

1. When the title displays "MEMORY SETUP", press the [Δ], [∇] keys or the [NEXT PAGE] Function Key to move the highlighted cursor to the memory name to be recalled.
2. Press the [RECALL] Function Key. The confirm window then displays
3. Press the [ENTER] key to confirm or press the [EXIT] Function Key to cancel.

4.5.2 Store Memory

1. When the title displays "MEMORY SETUP", press the [Δ], [∇] keys or the [NEXT PAGE] Function Key to move the highlighted cursor to the memory number position to be stored.
2. Press the [STORE] Function Key. The highlighted cursor becomes a blinking underscored cursor. Input the memory name by using the numeric/character keys. Pressing the same numeric/character keys repeatedly switches the display between numeric and alphabetic. Use the [NEXT CHAR] Function Key to move the blinking underscored cursor to the next character.
3. Press the [ENTER] key to confirm or press the [EXIT] Function Key to cancel.

4.5.3 Delete Memory

1. When title displays “MEMORY SETUP”, press the [△], [▽] keys or the [NEXT PAGE] Function Key to move the highlighted cursor to the memory name to be deleted.
2. Press the [DELETE] Function Key. The confirm window will then display.
3. Press the [ENTER] key to confirm or press the [EXIT] Function Key to cancel.

4.6 Setting Preset Parameter

4.6.1 Operation Methods

1. When title shows “PRESET SETUP”, press the [△], [▽] keys to move the highlighted cursor to the parameter item to be set.
2. Press the numeric/character key or Function Key to set the parameter.
3. Press [ENTER] to confirm or press [CLR] to reset.

4.6.2 Simple Setting Wizard

1. When title displays “PRESET SETUP”, press the [ENTER] key to move the highlighted cursor to the parameter to be set.
2. Press the numeric/character key or Function Key to set the parameter.
3. When the highlighted cursor is on the last parameter, press [ENTER] key will go to test parameter setting menu directly for user continuous setting.

PRESET SETUP	
01. Pass Hold	: 0.5 sec
02. Step Hold	: 0.2 sec
03. AC Freq.	: 60 Hz
04. GB Freq.	: 60 Hz
05. IEC-601	: OFF
06. GB Voltage	: 9.0 V
07. Auto Range	: OFF
08. Soft. AGC	: ON
09. Part No.	:
10. Lot No.	:
11. SERIAL No.	:
0.2-99.9s Remote Lock Offset Error	

Preset parameter function description table:

No.	Setting Item	Range	Initial Setting	Description
01	Pass Hold	0.2~99.9s	0.5	Length of time the PASS buzzer sounds and the Pass Relay on the Remote I/O will remain closed.
02	Step Hold	0.1~99.9s / KEY	0.2	Time interval between test procedure steps. KEY: Requires [START] key to be pressed before continuing to the next test step.
03	AC Freq.	50-600Hz	60	Frequency (Hz) of output voltage when running AC withstand test.
04	GB Freq.	50, 60Hz	60	Frequency (Hz) of output current when testing ground impedance.
05	IEC-601-1	ON/OFF	OFF	When the setting is ON: Test will initially apply ½ the programmed test voltage, then gradually apply a linear ramp to the test voltage over the programmed ramp time until the required test voltage is achieved. It then holds the voltage for the programmed test time then ramps back down identical to the ramp up (see waveform shown in Note 1.)
06	GB Voltage	6.0~9.0V	9.0	Open circuit voltage during ground bond testing.
07	Auto Range	ON/OFF	OFF	Sets withstand voltage auto-range function On or Off
08	Soft. AGC	ON/OFF	ON	Sets software auto gain compensation function On or Off.
09	Part No.	Not over 13 characters	Blank	Assigns a part number to the device under test.
10	Lot No.	Not over 13 characters	Blank	Assigns a lot number to the device under test.
11	Serial No. (Note 2)	Not over 13 characters	Blank	Assigns a serial number to the device under test.
12	Start Wait	0.1~99.9s / OFF	OFF	Delay time – after connection to the device is made and before current is applied to begin the ground bond test
13	Ramp Judg.	ON / OFF	ON	If Ramp Judg. Is set to ON, it will judge if the current value is over the High Limit setting value as the Ramp time is executed. If Ramp Judg. Is set to OFF, it will not judge if the current value is over the High Limit setting value as Ramp time is executed.

Note 1. When IEC-601-1 is set to ON, the output voltage waveform follows the pattern as shown below.

TEST					
	MODE	SOURCE	LIMIT	RES.	OFFSET
01	AC	1.000 kV	0.503 mA		
					Get Cs
					PAGE UP
					PAGE DOWN
					SCANNER-1
					1 2 3 4 5 6 7 8
					AC H
TEST TIME: 0.0s		Remote	Lock	Offset	Error

Figure 4-5

4.6.4 Start Wait Function

The Start Wait time is a delay time – after connection to the device is made and before current is applied to begin the ground bond test. This feature is normally used in a probing application. For example: If a 3 second start wait time is programmed, once the continuity between high and low GB connections is made, the unit waits the 3 sec. programmed start time, then applies current to the DUT.

1. Set Start Wait time, e.g., set to 3 seconds.
2. For example: CURRENT: 25.00A, HIGH LIMIT: 100mΩ, TEST TIME: 3.0sec. (See Figure 4-6)

TEST					
	MODE	SOURCE	LIMIT	RES.	OFFSET
01	GB	25.00 A	100.0 mΩ		
					Get Cs
					PAGE UP
					PAGE DOWN
					SCANNER-1
					1 2 3 4 5 6 7 8
					GB
		Remote	Lock	Offset	Error

Figure 4-6

3. After the DUT is connected, press [STOP], then [TEST] to start the test; the countdown starts as shown in Figure 4-7.

TEST					
	MODE	SOURCE	LIMIT	RES.	OFFSET
01	GB	25.00 A	100.0 mΩ		
					Get Cs
					PAGE UP
					PAGE DOWN
					SCANNER-1 1 2 3 4 5 6 7 8
					GB
GB CONTACT 2.3s					Remote Lock Offset Error

Figure 4-7

- After GB CONTACT, the timer counts down for three seconds (Start Wait setting time), and then the test starts, as shown in *Figure 4-8*.

TEST					
	MODE	SOURCE	LIMIT	RES.	OFFSET
01	GB	25.00 A	1.9 mΩ		
					Get Cs
					PAGE UP
					PAGE DOWN
					SCANNER-1 1 2 3 4 5 6 7 8
					GB
TEST TIME: 1.3s					Remote Lock Offset Error

Figure 4-8

- When the test ends, if the DUT PASSES, the display will show:

TEST					
	MODE	SOURCE	LIMIT	RES.	OFFSET
01	GB	25.01 A	1.9 mΩ		
					Get Cs
					PAGE UP
					PAGE DOWN
					SCANNER-1 1 2 3 4 5 6 7 8
					GB
WAIT GB OPEN..					Remote Lock Offset Error

Figure 4-9

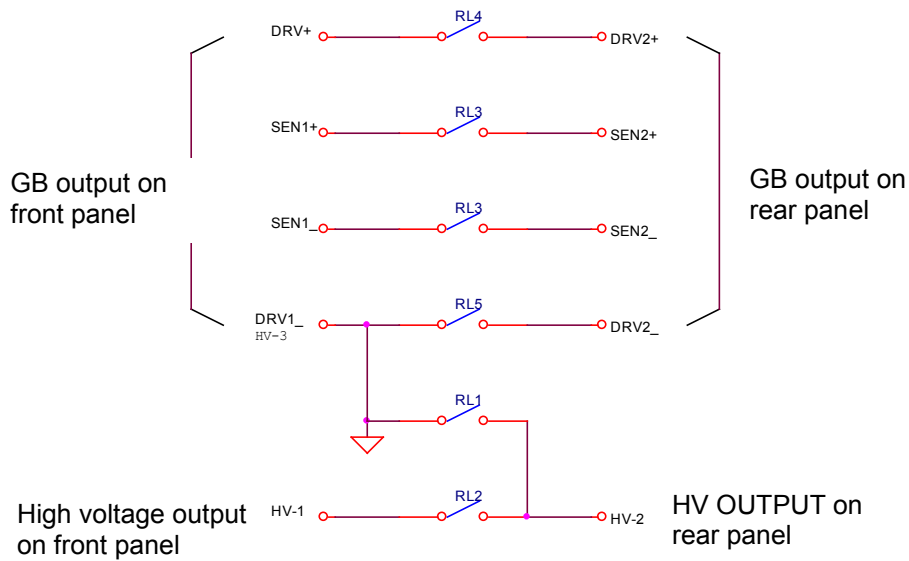

TEST 1: RL2, RL3, RL4, RL5 ----- ON, RL1 ----- OFF
 HV OUTPUT on rear panel is high voltage output.

TEST 2: RL1 ----- ON, RL2, RL3, RL4, RL5 ----- OFF
 HV OUTPUT on rear panel is GND, DRV2_ on rear panel is Floating.

4.8 Program Setting

4.8.1 Operation Methods

1. When the title list displays “STEP SETTING”, press the [△], [▽] keys to move the highlighted cursor to the parameter to be set.
2. Press the numeric/character keys or Function Keys to set the parameter data.
3. Press [ENTER] to confirm or press [CLR] to reset.

4.8.2 Parameters Setting Descriptions

TEST STEP: Sets the test step.

TEST MODE: Selects the test mode – GB / AC /DC /IR / LC (optional modes - PA / OCS).

The following sections describe the parameter settings of each test mode:

Ground Resistance Test Mode (GB)

CURRENT: Sets the ground resistance test current.

Note: Because the high limit (determined by multiplying the test current by the resistance) cannot be higher than 6.3V, the High limit for resistance will auto modify to an acceptable value when it does not correspondence to the above condition.

HIGH LIMIT: Sets the ground resistance judgment high limit value. The high limit value is 510mΩ or 6.3V/CURRENT.

LOW LIMIT :Sets the ground resistance judgment low limit value. The range is from 0 to

- the high limit of resistance. (0=OFF)
- TEST TIME : Sets the duration of the test. (0=CONTINUOUS)
- TWIN PORT : Selects twin port mode ON / OFF. When set to ON, and the next STEP is AC/DC or IR, the two steps can operate simultaneously. The highest AC rated current when twin port mode is selected should not exceed 5kV/20mA and GB current should not exceed 25A, or it may cause output voltage/current distortion.
- CHNL (H-L) : Sets the scan test point (set with optional device, for example 6000-01).

Withstanding Voltage Test Mode (AC)

- VOLTAGE: Sets the required voltage for the withstanding voltage test.
- HIGH LIMIT: Sets the leakage current high limit value.
- LOW LIMIT: Sets the leakage current low limit value. The range is \leq high limit value of leakage current or OFF.
- ARC LIMIT: Sets the arc current high limit value.
- ARC FILTER: Selects the frequency range of arc detection. Four ranges can be selected: 3~23 kHz / 3~50 kHz / 3~100 kHz / 3~230 kHz.
- TEST TIME: Sets the test duration time. (0=CONTINUOUS)
- RAMP TIME: Sets the ramp time. (0=OFF)
- FALL TIME: Sets the fall time of the voltage to 0. (0=OFF)
- CHNL (H-L): Sets the GB-Floating test selection point.

(1) When CHANNEL 3 is set H (high):

(a) Start test: The HV OUTPUT, DRIVE, and SENSE terminals on the front panel are connected to the HV OUTPUT, DRIVE, and SENSE terminals on the rear panel as shown below:

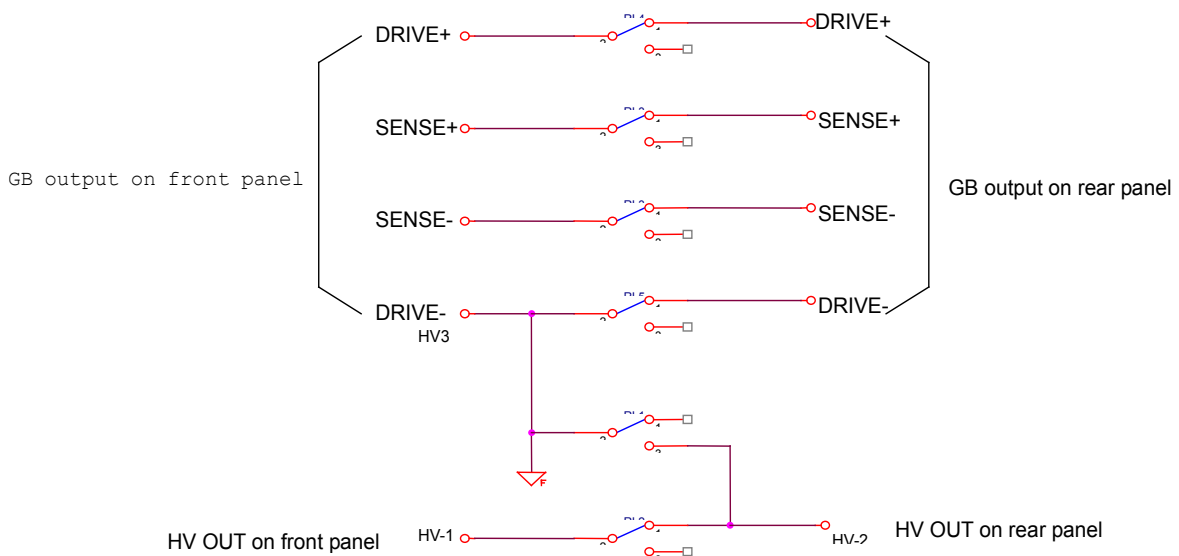

(b) End test: The HV OUTPUT terminals on the front and rear panels are connected. When the [STOP] key is pressed, the HV OUTPUT terminals on the front and rear panel are disconnected.

(2) When CHANNEL 3 is set L (low):

(a) Start test: The HV OUTPUT terminal on the rear panel and the DRIVE- on front panel are connected. The DRIVE and SENSE terminals on the front panel are disconnected from the DRIVE and SENSE terminals on rear panel as shown below:

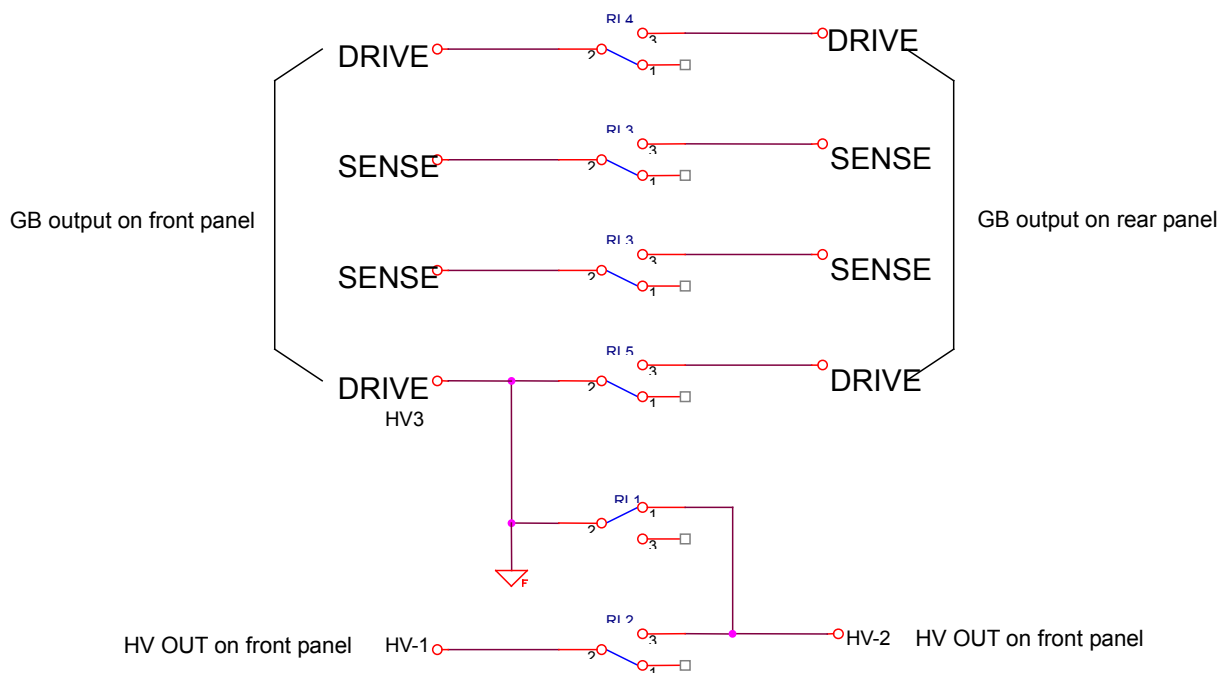

- (b) End test: The HV OUTPUT terminal on rear panel and the DRIVE-terminal on front panel are connected. When the [STOP] key is pressed, the HV OUT on the rear panel and the DRIVE-terminal on the front panel are disconnected. The DRIVE and SENSE terminals on the front panel are connected to the DRIVE and SENSE terminals on the rear panel.
- (3) When CHANNEL 3 is set as X (disable):
- (a) The HV OUTPUT terminals on the rear and front panels are disconnected.
 - (b) The DRIVE and SENSE terminals on the front panel are connected to the DRIVE and SENSE terminals on the rear panel.

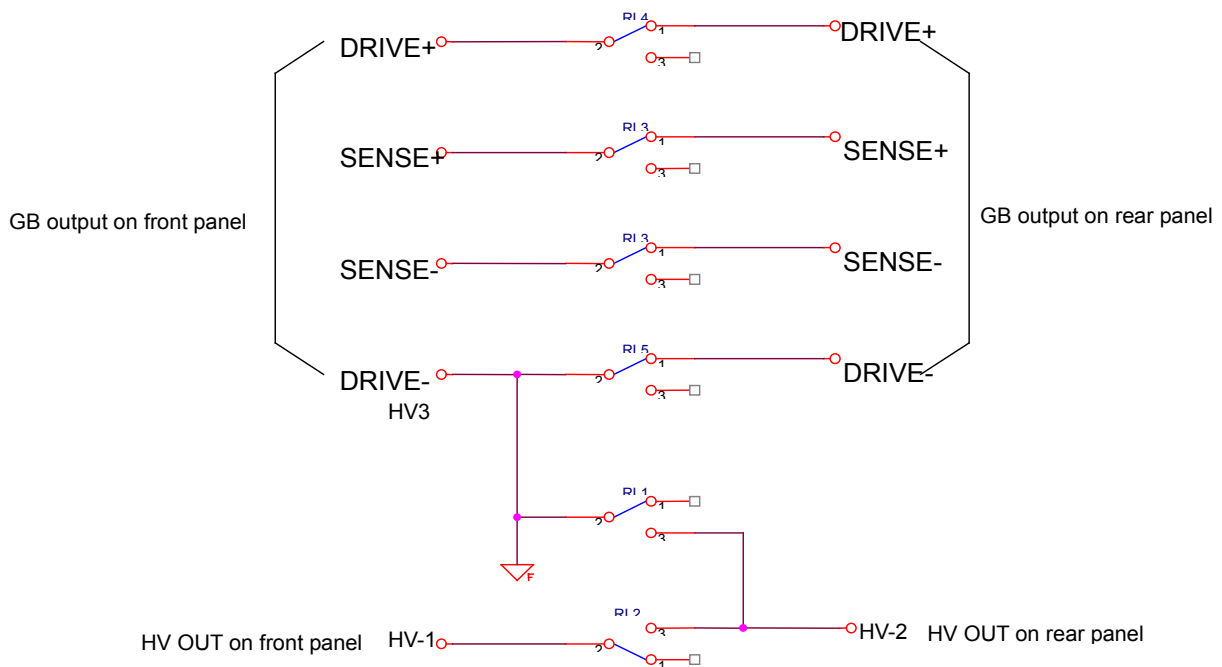

Example:

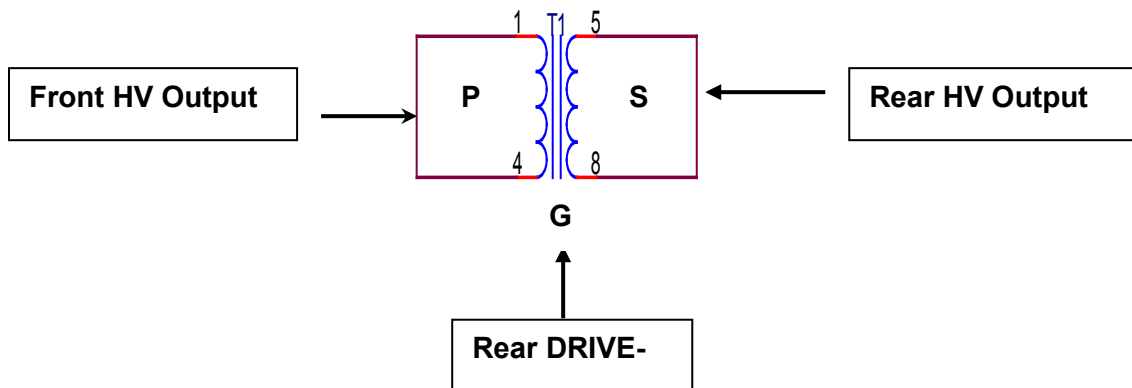

- (1) P – S: Sets CHANNEL 3 to L.
- (2) P – G: Sets CHANNEL 3 to X.
- (3) (P+S) – G: Sets CHANNEL 3 to H.

Or scanning test selection point (use with optional device, for example: 6000-03)

Withstanding Voltage Test Mode (DC)

- VOLTAGE : Sets the voltage for the withstanding voltage test.
- HIGH LIMIT : Sets the leakage current high limit value.
- LOW LIMIT : Sets the leakage current low limit value. The range is \leq leakage current high limit value or OFF.
- DWELL TIME: Sets the DWELL time. (0=OFF). (Do not read the high and low limit values of leakage current during the DWELL TIME. The limitation is not over 1.5 times the high limit range or high limit of leakage current.)
- ARC LIMIT : Sets the arc current high limit value.
- ARC FILTER : Selects the frequency range of detection arc. Four ranges can be selected: 3~23 kHz / 3~50 kHz / 3~100 kHz / 3~230 kHz.
- (TEST TIME : Sets the test duration time. (0=CONTINUOUS).
- RAMP TIME : Sets the ramp time. (0=OFF).

FALL TIME : Sets the fall time of the voltage to 0. (0=OFF).
 CHNL (H-L) : The setting is the same as AC CHANNEL.

Insulation Resistance Test Mode (IR)

VOLTAGE : Sets the insulation resistance test voltage.
 LOW LIMIT : Sets the insulation resistance low limit value.
 HIGH LIMIT : Sets the insulation resistance high limit value. The value is \geq insulation resistance low limit value or OFF.
 TEST TIME : Sets the test duration time. (0=CONTINUOUS)
 RAMP TIME : Sets the ramp time. (0=OFF)
 FALL TIME : Sets the fall time of the voltage to 0 (0=OFF)
 RANGE : Select the test file for the insulation resistance test (AUTO= Auto Range). The relationship between the current file and resistance measurement range is shown in the table below:

File	IR Value	
	Setting Voltage 50V ~ 250V	Setting Voltage 250V ~ 1000V
10mA(3 ~ 10mA)	0.1M Ω ~ 0.1M Ω	0.1M Ω ~ 1.0M Ω
3mA(0.3 ~ 3mA)	0.1M Ω ~ 0.9M Ω	0.1M Ω ~ 3.5M Ω
300uA(30 ~ 300uA)	0.1M Ω ~ 9.0M Ω	0.1M Ω ~ 29.9M Ω 25M Ω ~ 35M Ω
30uA(3 ~ 30uA)	0.1M Ω ~ 29.9M Ω 25M Ω ~ 90M Ω	0.1M Ω ~ 29.9M Ω 25M Ω ~ 249M Ω 0.20G Ω ~ 0.35G Ω
3uA(0.3 ~ 3uA)	0.1M Ω ~ 29.9M Ω 25M Ω ~ 249M Ω 0.20G Ω ~ 0.90G Ω	0.1M Ω ~ 29.9M Ω 25M Ω ~ 249M Ω 0.20G Ω ~ 3.33G Ω
300nA(20 ~ 300nA)	0.1M Ω ~ 29.9M Ω 25M Ω ~ 249M Ω 0.20G Ω ~ 2.00G Ω	0.1M Ω ~ 29.9M Ω 25M Ω ~ 249M Ω 0.20G Ω ~ 3.99G Ω 3.5G Ω ~ 19.9G Ω 15G Ω ~ 50G Ω

Note: Use the test voltage and insulation resistance of the DUT to calculate the value of current to choose the suitable current file.

CHNL (H-L): The setting is the same as AC/DC CHANNEL.
 Or scanning test selection point (use with optional device, for example 6000-03).

Leakage current test mode (LC) ---- Option

Pause test mode (PA)

MESSAGE: Message string. The string may be alphabetic, numeric, or symbolic [-] (max. 13 characters.)

UNDER TEST: Set to ON or OFF.

- (1) When set to ON: the UNDER TEST relay terminal on the rear panel is closed.
- (2) When set to OFF: the UNDER TEST relay terminal on the rear panel is open.

TEST TIME: Set the action method of pause mode.

- (1) When set to CONTINUE, pause mode will be ended till press [START] on panel or re-trigger START signal on rear panel.

(2) Setting range 0.3 to 999sec: When the setting time is up then end the pause mode.

Open/Short Circuit Detection Mode (OSC)

OPEN CHK : Set the judgment test result to open condition (compare the test reading with the read standard capacitance value [Cs]).

SHORT CHK : Set the judgment test result to short condition (compare the test reading with the read standard capacitance value [Cs]).

CHNL (H-L) : The setting is the same as AC/DC CHANNEL.

4.9 How to Process Test

4.9.1 Offset Value Calibration of Test Cable / Fixture

1. Ground test adaptable test cable plug in (+) and (-) terminals of DRIVE and SENSE. And then makes test cable short-circuit (be sure under grounding test status now). Press the [OFFSET] Function Key. The display will show the "MESSAGE" window.
2. After pressing the [START] key, the title will show "GET OFFSET TEST".
3. The DANGER LED on the front panel turns ON. Current is output for five seconds (when the TEST TIME is set to CONTINUE). The analyzer starts to measure the resistance of the test cable and shows its value on the display. It is then stored in the memory.
4. When the test time ends, [OFFSET] is highlighted.
5. Press the [START] again and if the line resistance of measured test cable is 0 ~ 0.1mΩ, it means line resistance of test cable had been deducted.

4.9.2 Standard Capacitance Value (GET Cs) Description

1. Before starting an open/short circuit detection mode (OSC Mode) test or changing the capacitance under test, acquire the standard capacitance value (GET Cs).
2. Before reading the standard capacitance value (GET Cs), press the [OFFSET] Function Key to do the OFFSET elimination. Do an OFFSET elimination when changing wires or fixtures to ensure the accuracy of the testing.
3. Before reading the standard capacitance value (GET Cs), use the standard capacitance sample in testing as the DUT. Press the [GET Cs] Function Key to read the standard capacitance value for the standard value in testing.
4. When running an open/short circuit detection mode (OSC Mode) test, the OPEN/SHORT test pass or fail condition is based on the GET Cs reading.

4.9.3 DUT Connecting Methods

Ground Resistance Test Mode (GB)

Ensure there is no output current and the DANGER LED is OFF. Attach the test cables to the terminals using a box spanner and then connect the test cables to the DUT.

 **CAUTION** : Ensure the ground cable has been tightened with a box spanner

Withstand Voltage / Insulation Resistance Test Mode (AC / DC / IR / OSC)

Ensure there is no output voltage and the DANGER LED is OFF. Connect the black ground

cable to the DRIVE (-) terminal of the analyzer. Short this test cable and the high voltage output terminal together and confirm there is no high voltage output. Plug the red or white high voltage test cable into the high voltage OUTPUT terminal. Connect the ground test cable to the DUT first, and then connect the high voltage test cable to the DUT.

4.9.4 Test Procedure

4.9.4.1 GB/AC/DC/IR Test Procedure

1. Connect the DUT via correct connection.
When the title shows "MAIN MENU", press the [TEST] Function Key to enter the TEST function list; the title will display "TEST". The display shows a list of STEPs which are set and waiting for testing. The first field is STEP, the second field is test mode, the third field is the test value, the fourth field is the output high limit value, and the fifth field is the test result.
2. Press the [STOP] key.
Press the [START] key to start the test. When this key is pressed, high voltage will be output and the DANGER LED will be illuminated.

⚠ WARNING The test is now running with the maximum current / voltage output applied to the DUT. Use extreme caution when working near the analyzer or the DUT.

The third field will show the output current / voltage reading, the fourth will show the output resistance / current reading. The timer counts down or starts to count and shows on status list.

3. PASS judgment
When all the tests have been completed and the fifth field test result shows PASS, then the DUT is judged as GOOD and the output is stopped. The rear panel outputs the PASS signal and the buzzer is turned ON.
4. FAIL judgment
If the measurement value is abnormal, the DUT is judged as FAIL and the output is stopped. The rear panel outputs the FAIL signal and the buzzer is turned ON. The analyzer stays on the function until the **STOP** key is pressed. The fifth field test result shows FAIL.

Fail Status Description Table

Test result	Meaning
HIGH	Measurement current / Resistance value over high limit
LOW	Measurement current / Resistance value under low limit
ARC	Current arc over high limit
ADNO	Voltage / current reading over hardware valid digit.
ADIO	Current / resistance reading over hardware valid digit.
Curr	Current reading-Set current >1 ampere
PWHI	Power measurement value over high limit
PWLO	Power measurement value under low limit

Press the [STOP] key to stop test output.

4.9.4.2 OSC Test Procedure

1. Connect the DUT via correct connection.
When the title shows "MAIN MENU", press the [TEST] Function Key to enter the TEST function list. The title will display "TEST". The display shows a list of STEPs which are set and waiting for testing. The first field is STEP, the second field is test mode (OSC), the third field is output voltage setting value, the fourth field is capacitance reading, and the fifth field is test result.
2. Press the [STOP] key.
Press the [START] key to start the test. When this key is pressed, high voltage will be output and the DANGER LED will be illuminated.

WARNING The test is now running with the maximum current / voltage output applied to the DUT. Use extreme caution when working near the analyzer or the DUT.

The third field will show the output voltage reading and the fourth will show the capacitance reading. The timer counts down and displays on the status list.

3. PASS judgment
When all the tests have been completed and the fifth field test result shows PASS, then the DUT is judged as GOOD and the output is stopped. The rear panel outputs the PASS signal and the buzzer is turned ON.
4. FAIL judgment
If the measurement value is abnormal, the DUT is judged as FAIL and the output is stopped. The rear panel outputs the FAIL signal and the buzzer is turned ON. The analyzer stays on the function until the [STOP] key is pressed. The fifth field test result shows FAIL.

Fail Status Description Table

Test result	Meaning
OPEN	Capacitance open circuit/reading is less than OPEN CHK setting.
SHORT	Capacitance short circuit/reading is greater than SHORT CHK setting.

Press the [STOP] key to stop the test output.

Note The valid display digit of capacity in OSC mode is determined by the Cs current range.
Example:
Get Cs voltage 0.018kV, Get Cs capacitance value 17.4nF, current= 1.18mA -- at the max current range.
Get Cs voltage 0.016kV, Get Cs capacitance value 17.42nF, current= 0.97mA -- at the medium current range.

4.10 CALIBRATION Function

4.10.1 Enable Calibration

The instrument requires a minimum 30-minute warm up period prior to calibration. With the instrument in standby status ([STOP] button previously pressed and no lights flashing), remove the front panel calibration seal and push (using the tip of a small screwdriver) the recessed switch through the hole in the front panel labeled **Cal- Enable** (to the in position).

1. With the title list displaying “MAIN MENU”, press the numeric key [4] that corresponds to CALIBRATION. The display will show “ENTER CALIBRATION PASSWORD”.
2. Using the numeric keys, input [7] [9] [3] [1] [ENTER].
3. After the [ENTER] key has been pressed, select **[DEVICE]**.

4.10.2 Clear Memory

All stored test conditions in instrument memory (100 setups) may be cleared. NOTE: all preset and option parameters are cleared as well as all memory locations. All parameters will be reset to default values.

1. With the title list displaying “MAIN MENU”, press the numeric key [4] that corresponds to CALIBRATION. The display will show “ENTER CALIBRATION PASSWORD”.
2. Using the numeric keys, input [8] [5] [2] [4] [6] [ENTER].
3. After the [ENTER] key has been pressed, the instrument displays the message: “Clear Memory?”
4. Press the [YES] Function Key to clear all memory.
5. Press the [NO] Function Key to abort the clear all memory function.
6. Press [EXIT] to return to MAIN MENU.
7. After the memory has been cleared, all option parameters need to be reset.

4.11 KEY LOCK Function

When KEY LOCK is ON, the **LOCK** status LED on the display is illuminated and the MEMORY and TEST functions are operational.

Setting KEY LOCK:

1. When the title list displays “MAIN MENU”, if “LOCK” is not highlighted, press the numeric key that corresponds to KEY LOCK [4], to display the “KEY LOCK” window.
2. Using the numeric keys, input [0][0][0][0] [ENTER] (See **Note 1** below).
3. After pressing the [ENTER] key the display will show the “MESSAGE” window with the “LOCK” text block highlighted. Select whether to lock or not lock the “MEMORY RECALL” function using the [YES], [NO] Function Keys.
4. Press [EXIT] to complete setting the KEY LOCK function.

- Note**
1. If the Security Code has been changed, [0][0][0][0][ENTER] will not work for KEY LOCK. Use the new Security Code.
 2. When the 19032 is powered down with KEY LOCK ON, it will boot to the TEST menu when powered back ON.

Cancelling KEY LOCK:

1. When the title list displays “MAIN MENU”, if “LOCK” is not highlighted, press the numeric key that corresponds to KEY LOCK [4], to display the “RELEASE KEY LOCK” window.
2. Using the numeric keys, input [0][0][0][0] [ENTER] (See **Note 1** above).
3. Press [EXIT] to complete cancelling the KEY LOCK function.

4.12 User Password Setting

The initial user password is [0][0][0][0]. A password of up to 12 numeric characters may be set.

1. When the title list displays "MAIN MENU", press the numeric key that corresponds to NEW SECURITY CODE [5] to display the "ENTER USER PASSWORD" window.
2. Using the numeric keys, input [0][0][0][0] (when PASSWORD is not set – see NOTE below). Press the [ENTER] key to display the "ENTER NEW PASSWORD" window.
3. Using the numeric keys, enter the NEW PASSWORD (the maximum is twelve characters). Press the [ENTER] key to display the "ENTER CONFIRM PASSWORD" window.
4. Using the numeric keys, enter the CONFIRM PASSWORD (which is the same as NEW PASSWORD). Press the [ENTER] key to display the "MESSAGE" window (the new PASSWORD has been set.)
5. Press any key to EXIT.

Note | If the password has been forgotten, follow the steps in section 4.10.2 "Clear Memory" to
 | clear the memory. The PASSWORD will be reset to the initial value, *i.e.* 0000.

4.13 FAIL LOCK Function

4.13.1 Setting FAIL LOCK

When FAIL LOCK is ON, the **LOCK** status LED on the display is illuminated and only the TEST function is operational. Use Fail Lock when a supervisor is to be notified when a failure occurs. Once a failure occurs, no test can be run until the password is entered.

1. When the title list displays "MAIN MENU", press the numeric key that corresponds to FAIL LOCK [6] to display the "FAIL LOCK" window.
2. Using the numeric keys, input the PASSWORD [0] [0] [0] [0] (or the NEW SECURITY CODE if it has been set).
3. Press the [ENTER] key. The [LOCK] will be highlighted. All keys are locked except for [STOP], [START], [TEST] Function Key, and FAIL LOCK, until the FAIL LOCK function is unlocked.
4. If the DUT fails a test, the FAIL LOCK function will be activated, as shown in *Figure 4-11*.

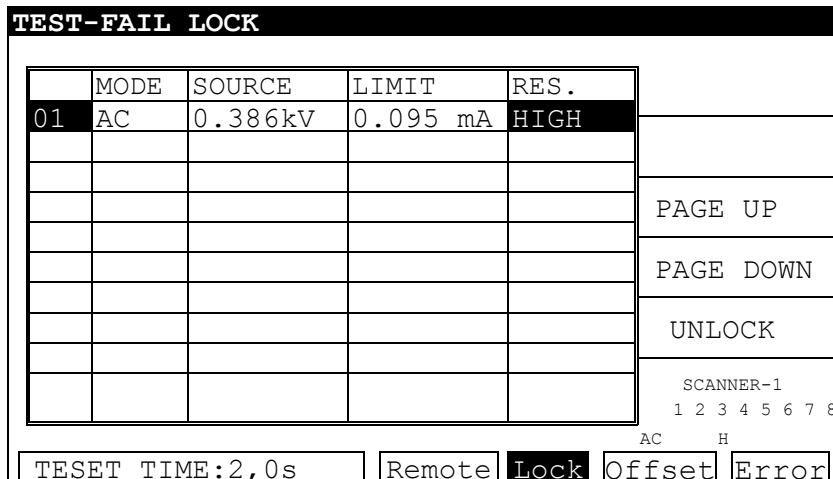

Figure 4-11

5. Press the [STOP] key then [UNLOCK] to clear the buzzer sound. The display will show the “UNLOCK” window.
6. Using the numeric keys, input the PASSWORD [0] [0] [0] [0] (or the NEW SECURITY CODE if it is set).
7. Press the [START] key to restart the test.
8. Press [MENU] to return to the MAIN MENU.

- Note**
1. If the User Password has been changed, [0][0][0][0][ENTER] will not work for FAIL LOCK. Use the new User Password.
 2. When the 19032 is powered down with FAIL LOCK ON, it will boot to the TEST menu when powered back ON.

4.13.2 Release FAIL LOCK

1. When the title list displays “MAIN MENU”, press the numeric key which corresponds to FAIL LOCK [6] to display the “RELEASE FAIL LOCK” window.
2. Using the numeric keys, input the PASSWORD [0] [0] [0] [0] (or the NEW SECURITY CODE if it has been set).
3. Press the [ENTER] key. The FAIL LOCK function will be turned off and the display will show the “LOCK” window.

4.14 Remote Control

This analyzer has two terminal strips and a 9 pin D-series connector on the rear panel for remote control. There is a black 6 screw relay strip for the remote output signals: UNDER TEST, PASS, & FAIL. There is a black 5 screw relay strip for the remote input connections: START, RESET, COM, & INTER LOCK. Inputs require a contact closure and outputs provide a contact closure, as shown in Figure 4-15. To control this analyzer with an external signal, connect the signal cable to the appropriate terminal. Remote control is generally controlled by the high voltage probe; however, other control circuits can also be used to control it instead. The test bar is the switch for controlling the high voltage output, so the connected control wire should not be near the high voltage site and test cable to avoid causing any hazard.

1. Remote control can be by individual START and STOP signals or by a continuous signal, as shown in *Figures 4-12 and 13*.

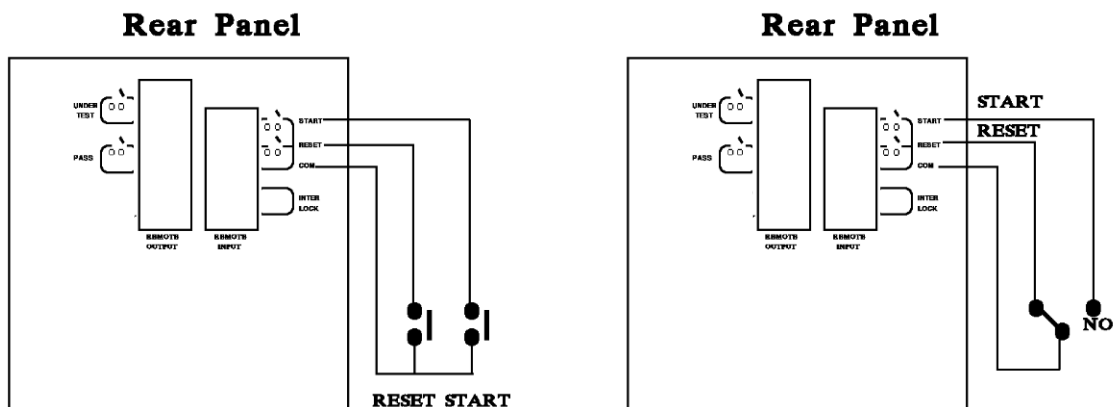

Figure 4-12 – Single Control of START and STOP Figure 4-13 – Continuous Control of STOP

2. As shown in *Figure 4-13*, the analyzer is under STOP status (the NC contact is connected to STOP and the NO contact is connected to START.)
3. Logic components such as transistors, FETs, optocouplers, etc., can also be used for control circuits, as shown in *Figure 4-14*.
4. The control signals should be within the following ranges:
 - (1) The HIGH signal voltage should be between 4.5 and 5V.
 - (2) The LOW signal voltage should be between 0 and 0.6V.
 - (3) The LOW signal current should be 2mA or less.
 - (4) The control signals should be active for at least 20mS.

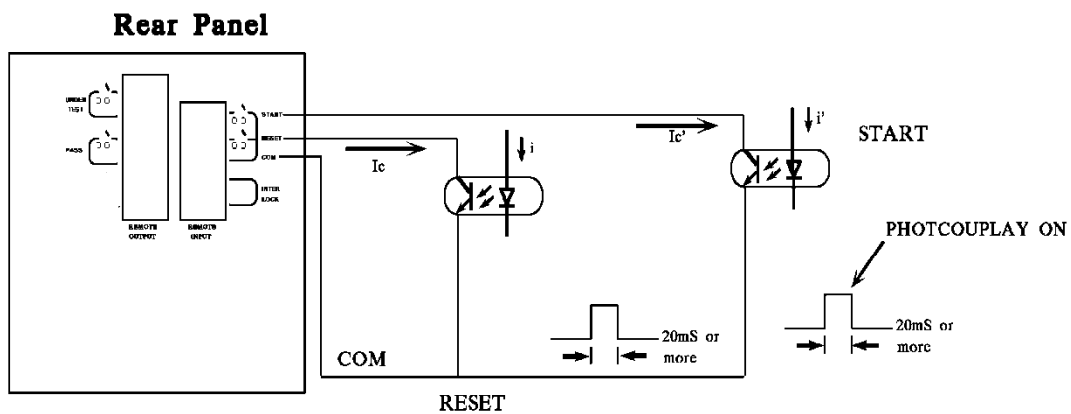

Figure 4-14

5. The relay switch control shown in *Figure 4-12* and the optocoupler control shown in *Figure 4-14* both provide contact closure. Avoid interference on the signal lines to prevent unexpected system operation.
6. The REMOTE CONTROL pin diagram is shown in *Figure 4-15*. Use this pin diagram when connecting external control signals.

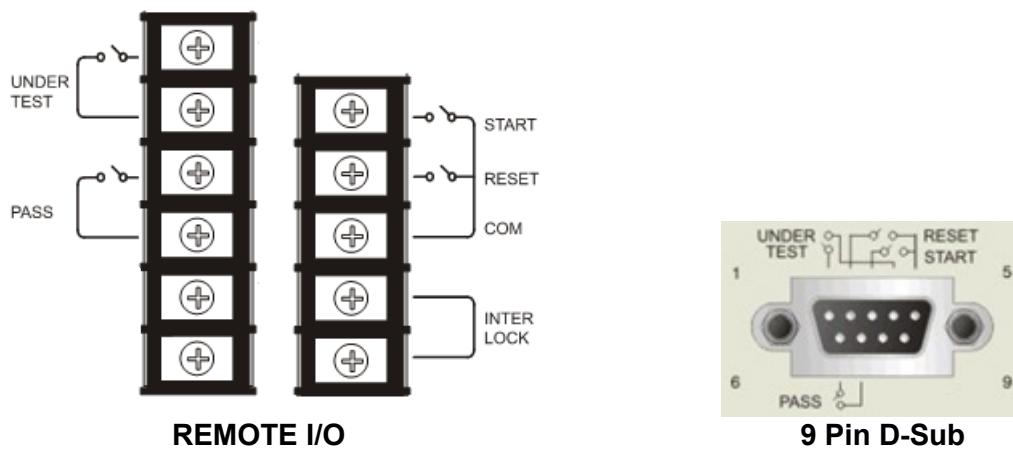

Figure 4-15

4.15 Output Signal

The analyzer has two internal signal indications: LED and buzzer. The rear panel of the analyzer has the following output signals:

UNDER TEST: While the analyzer is running a test, this relay output terminal will be closed. This closed condition can be used to control an external signal. The relay contacts can support 115V AC, <0.3A.

PASS: When the DUT passes a test, this relay output terminal will be closed. This closed condition can be used to control an external signal. The relay contacts can support 115V AC, <0.3A. This signal will remain until the RESET signal is received.

4.16 Timing Diagram

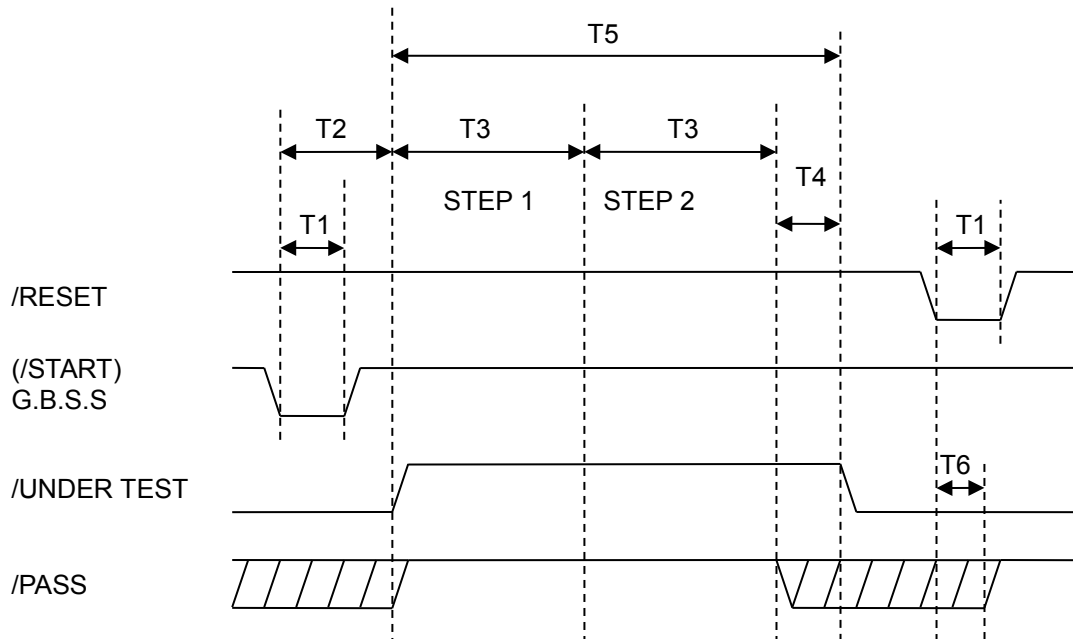

Timing diagram example for two test steps

Time	Limit	Description
T1	> 20mS	External trigger signals /START and /RESET need to be at least 20mS in duration.
T2	< 200mS	The time of external trigger signal /START to /UNDER TEST signal to be cleared, it will be smaller than 200mS. The previous STEP test result /PASS signal status has been cleared in advance.
	< 300mS	The time of external trigger signal /START to /UNDER TEST signal to be cleared, it will be smaller than 300mS. The previous STEP test result /PASS signal status hasn't been cleared in advance.
T3	-	Test time of the test steps.
T4	> 15mS	/PASS signal sent larger than 15mS, /UNDER TEST signal is end.
T5	-	The time used for testing. The signal is simultaneous with Danger lamp on panel.
T6	>5mS	/RESET signal sent larger than 5mS, /PASS signal is ended.

4.17 Test Parameter and Example

4.17.1 Single Test Mode

a. Grounding resistance test __ GB MODE

MAIN MENU	
1 -> SYSTEM	MEMORY
2 -> OPTION	PRESET
3 -> CALIBRATION	
4 -> KEY LOCK	PROGRAM
5 -> NEW SECURITY CODE	
6 -> FAIL LOCK	
7 -> ERROR LOG	TEST
<input type="text"/> Remote Lock Offset Error	

Figure 4-16

After turning on the analyzer, press the [PROGRAM] Function Key on the right side of the MAIN MENU (see *Figure 4-16*) to enter the STEP SETTING screen. Move to TEST MODE by pressing the [▽] key and select GB MODE as shown in *Figure 4-17*. Step through the menu and enter all of the parameter values.

STEP SETTING	
01. TEST STEP :	1 GB
02. TEST MODE :	GB
03. CURRENT :	25.00 A AC
04. HIGH LIMIT :	100.0 mΩ
05. LOW LIMIT :	OFF DC
06. TEST TIME :	3.0 sec
07. TWIN PORT :	ON IR
08. CHNL (H-L) :	LC
PAGE 1/2	
<input type="text"/> Remote Lock Offset Error	

Figure 4-17

Set the following parameters as required by the test:

01. TEST STEP: Select the number of the test step to set the parameters for.
02. TEST MODE: Select the test mode – GB / AC /DC /IR / LC (optional modes - PA / OCS)
03. CURRENT: Set the required current – 1 - 30A
04. HIGH LIMIT: Set the high limit - 0.1 - 510mΩ
05. LOW LIMIT: Set the low limit – 0 - HIGH (0 = OFF)
06. TEST TIME: Set the test duration time - 0.3 – 999 Sec (0 = CONTINUOUS)
07. TWIN PORT: Select ON or OFF (When this function is ON, STEP 2 can be set as AC, DC, or IR in order to execute a Twin Port test for STEP1 and STEP2 simultaneously.)
08. CHNL: Press the (SETUP) Function Key.

After completing the parameter settings, return to the MAIN MENU by pressing the [MENU] key and then press the [TEST] Function Key to enter the TEST menu (see *Figure 4-18.*)

(TWIN PORT: OFF)

TEST					
	MODE	SOURCE	LIMIT	RES.	OFFSET
01	GB	25.00 A	100.0 mΩ		
					Get Cs
					PAGE UP
					PAGE DOWN
					SCANNER-1 1 2 3 4 5 6 7 8
					GB
Standby					Remote
					Lock
					Offset
					Error

Figure 4-18

Press the [STOP] then [START] Function Keys to start the test.

(TWIN PORT: ON)

EX: STEP 2 set IR

TEST					
	MODE	SOURCE	LIMIT	RES.	OFFSET
01	GB	25.00 A	100.0 mΩ		
02	IR	0.500 KV	1.0 MΩ		
					Get Cs
					PAGE UP
					PAGE DOWN
					SCANNER-1 1 2 3 4 5 6 7 8
					GB
Standby					Remote
					Lock
					Offset
					Error

Figure 4-19

Press the [STOP] then [START] Function Keys on this menu to start the test.

b. Withstanding test __ AC Mode

After entering the STEP SETTING menu, move to TEST MODE by pressing the [▽] key and select AC MODE as shown in *Figure 4-20.* Step through the menu and enter all of the parameter values.

STEP SETTING			
01. TEST STEP	:	1	GB
02. TEST MODE	:	AC	
03. VOLTAGE	:	OFF	AC
04. AC FREQ.	:	DEFAULT	
05. HIGH LIMIT	:	0.500 mA	DC
06. LOW LIMIT	:	OFF	
07. ARC LIMIT	:	OFF	IR
08. ARC FILTER	:	3-230 kHz	
09. TEST TIME	:	3.0 sec	LC
10. RAMP TIME	:	OFF	
11. FALL TIME	:	OFF	PAGE 1/2
12. CHNL (H-L)	:	OFF	
SELECT MODE Remote Lock Offset Error			

Figure 4-20

Set the following parameters as required by the test:

01. TEST STEP: Select the number of the test step to set the parameters for.
02. TEST MODE: Select the (AC) test mode
03. VOLTAGE: Set the required voltage - 0.05 - 5KV
04. AC FREQ.: Set the require frequency – 50 - 600Hz (0=DEFAULT)
05. HIGH LIMIT: Set the high limit - 0.001 - 40mA
06. LOW LIMIT: Set the low limit – 0 - 40mA (0 = OFF)
07. ARC LIMIT: Set the arc limit – 1 -30 mA (0 = OFF)
08. ARC FILTER: Select the filter range (3-23kHz / 3-50kHz / 3-100kHz / 3-230kHz)
09. TEST TIME: Set the test duration time - 0.3 – 999 Sec (0 = CONTINUOUS)
10. RAMP TIME: Set the ramp time – 0 – 999 Sec (0 = OFF)
11. FALL TIME: Set the fall time – 0 – 999 Sec (0=OFF)
12. CHNL (H-L): Press the (SETUP) Function Key

Press the [SETUP] Function Key to enter the SETUP SCANNER-1 menu:

STEP SETTING			
01. TEST STEP	:	1	
02. TEST MODE	:	AC	
03. VOLTAGE	:	OFF	
SETUP SCANNER-1			
		1 2 3 4 5 6 7 8	NEXT BOX
		X X X X X X X X	
09. TEST TIME	:	3.0 sec	
10. RAMP TIME	:	OFF	
11. FALL TIME	:	OFF	EXIT
12. CHNL (H-L)	:	OFF	
PRESS NUMBER KEYS Remote Lock Offset Error			

Figure 4-21

Press the numeric Key [3] repeatedly to select H, L, or X.

H: The HV OUTPUT on both the front and rear panels are ON.

L: The HV OUTPUT on the rear panel and the DRIVE- on front panel are short grounded. The DRIVE- on the rear panel is floating.

X: The HV OUTPUT on both the front and rear panels are open circuit. GB terminals on the front and rear panels are ON.

After the parameter settings have been completed, press the [EXIT] and [MENU] keys to return to the MAIN MENU and then press the [TEST] Function Key to enter the TEST menu as shown in *Figure 4-22*.

TEST					
	MODE	SOURCE	LIMIT	RES.	OFFSET
01	AC	1.000 kV	0.500 mA		
					Get Cs
					PAGE UP
					PAGE DOWN
					SCANNER-1
					1 2 3 4 5 6 7 8
					AC H
Standby		Remote	Lock	Offset	Error

Figure 4-22

Press the [STOP] then [START] Function Keys to the start test.

c. Withstanding test __ DC Mode / Insulation resistance test __ IR Mode

Setting methods are the same as **b. Withstanding test __ AC Mode**.

d. Open/Short circuit detection test __ OSC Mode

After entering the STEP SETTING menu, press the [▽] key to move to TEST MODE to select OSC MODE. Step through the menu and enter all of the parameter values as shown in *Figure 4-23*.

STEP SETTING			
01. TEST STEP	:	1	PA
02. TEST MODE	:	OSC	
03. OPEN CHK.	:	50%	OSC
04. SHORT CHK.	:	300%	
05. CHNL (H-L)	:	OFF	
			PAGE 2/2
SELECT MODE		Remote	Lock
		Offset	Error

Figure 4-23

Set the following parameters as required by the test:

01. TEST STEP: Select the number of the test step to set the parameters for.
02. TEST MODE: Select the (OSC) test mode
03. OPEN CHK: Set the pass/fail test result to open condition (compare the test reading with the standard capacitance value [Cs]).
04. SHORT CHK: Set the pass/fail test result to short condition (compare the test reading

with the standard capacitance value [Cs]).
 05. CHNL (H-L): The same as AC/DC CHANNEL setting.

4.17.2 Auto Mode Setting

STEP 1: GB

STEP SETTING	
01. TEST STEP	: 1 UP
02. TEST MODE	: GB
03. CURRENT	: 3.00 A
04. HIGH LIMIT	: 100.0 mΩ
05. LOW LIMIT	: OFF DOWN
06. TEST TIME	: 3.0 sec
07. TWIN PORT	: OFF
08. CHNL (H-L)	: INSERT
	: DELETE
SELECT STEP	
Remote Lock Offset Error	

STEP 2: AC

STEP SETTING	
01. TEST STEP	: 2 UP
02. TEST MODE	: AC
03. VOLTAGE	: 0.050 KV
04. HIGH LIMIT	: 0.500 mA
05. LOW LIMIT	: OFF DOWN
06. ARC LIMIT	: OFF
07. ARC FILTER	: 3-230 kHz
08. TEST TIME	: 3.0 sec
09. RAMP TIME	: OFF INSERT
10. FALL TIME	: OFF
11. CHNL (H-L)	: OFF DELETE
SELECT STEP	
Remote Lock Offset Error	

STEP 3: IR

STEP SETTING	
01. TEST STEP	: 3 UP
02. TEST MODE	: IR
03. VOLTAGE	: 0.050 KV
04. LOW LIMIT	: 0.1 MΩ
05. HIGH LIMIT	: OFF DOWN
06. TEST TIME	: 3.0 sec
07. RAMP TIME	: OFF
08. FALL TIME	: OFF
09. RANGE	: AUTO INSERT
10. CHNL (H-L)	: OFF DELETE
SELECT STEP	
Remote Lock Offset Error	

Test Step

- a. Confirm there is no voltage output and the high voltage output DANGER LED is not illuminated. Connect the test cable (black) for low potential to the DRIVE- terminal on the rear panel. Secure the fixed flap, short circuit the test cable and high voltage output terminal. Confirm there is no high voltage output.
- b. Plug the two high voltage test cables (red or white) into the HV OUTPUT terminal (High) on the front panel and HV OUT (Low) on the rear panel. Connect the low potential test cable to the DUT and then connect the high potential test cable to the DUT.
- c. When doing the $P_{(L+N)} - S$ withstanding test, the ground terminal is Floating, as shown below:

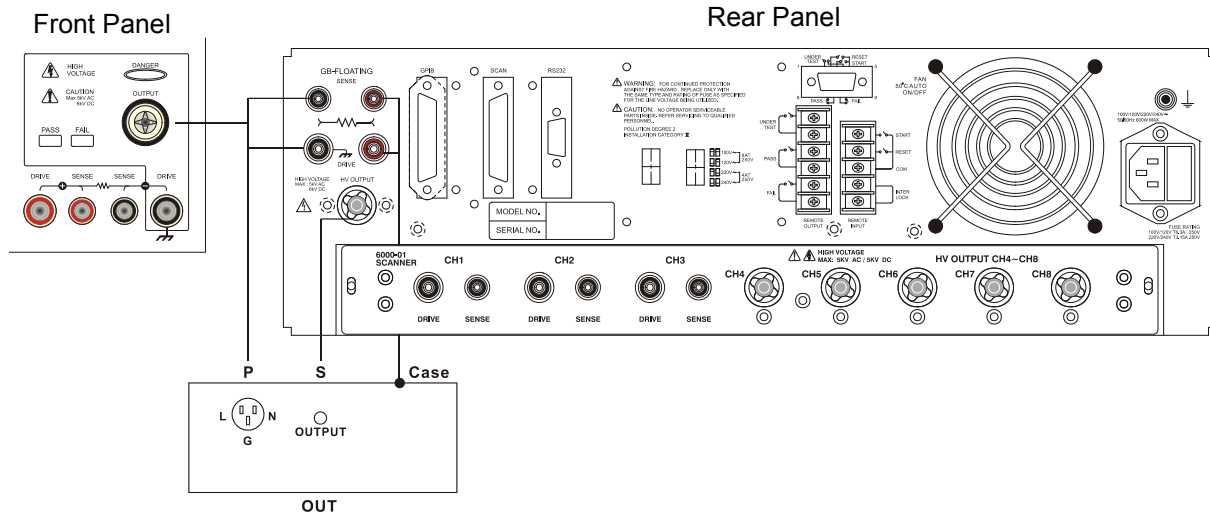

5. GPIB/RS-232 Operation Description (IEEE-488.2)

5.1 Guide

A computer can be used for remote control of the 19032 using either a GPIB (IEEE 488-1978) or RS-232 interface.

The IEEE-488 (GPIB) address is defined in the [OPTION] submenu by selecting [MENU] [2] and [GPIB].

The 19032 is in a remote control status when the **REMOTE** LED is ON.

To switch to Local from Remote press the [LOCAL] Function Key. (The [LOCAL] key may be disabled by the LLO [Local lockout] command message.)

The only control functional under Remote operation is [LOCAL], which switches to Local, and [STOP], which resets the unit.

5.2 GPIB Interface Specification

5.2.1 Adaptable Standard

IEEE488-1978 standard

5.2.2 Interface Capability

Code	Meaning
SH1	Source Handshake
AH1	Acceptor Handshake
T4	Basic Talker requirement
L4	Basic Listener requirement
SR1	Service request requirement
RL1	All remote/local requirement
PP0	No Parallel poll requirement
DC1	All device clear requirement
DT0	No Device trigger requirement
C0	No controller requirement

5.2.3 Interface Message

The analyzer is capable of responding to the following messages.

Messages	Meaning	Response
GTL	Go To Local	Switches unit to LOCAL mode.
SDC	Selected Device Clear	Resets the unit.
LLO	Local Lockout	Disables [LOCAL] switch to local mode.
IFC	Interface Clear	Resets the GPIB interface.

5.2.4 Command Format Descriptions

The interface function is controlled by ASCII commands which include:

{[command + parameter] ; [command + parameter] + ending code}

The length of the command string is limited to 1024 characters (including the end code). It is not necessary to input any sign or space between the command and parameter. Any two commands can be connected by ";" and [Ending Code]. The Ending Code can be any type in the following table:

Ending Codes

LF
CR + LF
EOI
LF + EOI
CR + LF + EOI

5.2.5 GPIB Related Panel Descriptions

1. Address Setting

- Under "MAIN MENU", press the numeric key [2] to enter the "OPTION MENU".
- Press the [GPIB] Function Key to enter the "GPIB SETUP" menu and then select the GPIB Address using the [UP] or [DOWN] Function Keys.
- Press the [EXIT] Function Key to exit.

2. Remote / Local

- If "Remote" is highlighted in the signal block, the analyzer is in "Remote" status.
- In "Remote" status the [LOCAL] key on the front panel can be used to switch the analyzer to LOCAL status.
- In Remote status, all of the panel keys are disabled except for [LOCAL] (switch to Local) and [STOP] (reset instrument) keys.
- The LLO [Local lockout] command disables the [LOCAL] key.

5.3 RS-232 Interface Specification

5.3.1 Data Format

Baud Rate: 300 / 600 / 1200 / 2400 / 4800 / 9600 / 19200
 Parity: NONE / ODD / EVEN
 Flow control: NONE / SOFTWARE
 Bits: 1 start bit
 8 data bits or 7 data bits add 1 parity bit
 1 end bit

5.3.2 Command Format Descriptions

The interface function is controlled by ASCII commands which include:

{[command + parameter] ; [command + parameter] + ending code}

The length of the command string is limited to 1024 characters (including the end code). It is not necessary to input any sign or space between the command and parameter. Any two commands can be connected by ";" and [Ending Code]. The Ending Code can be any type in the following table:

End of String

LF
CR + LF

5.3.3 Connector

RS-232 9 pin female connector configuration/descriptions:

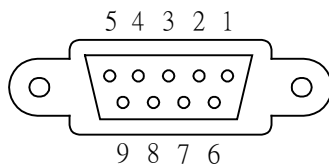

Pin No.	Description
1 *	Not used
2 TxD	Transmit data
3 RxD	Receive data
4 *	Not used
5 GND	Signal ground
6 *	Not used
7 *	Not used
8 *	Not used
9 *	Not used

5.3.4 Cable Wiring Pattern

RS-232 9 pins female connector wiring diagram.

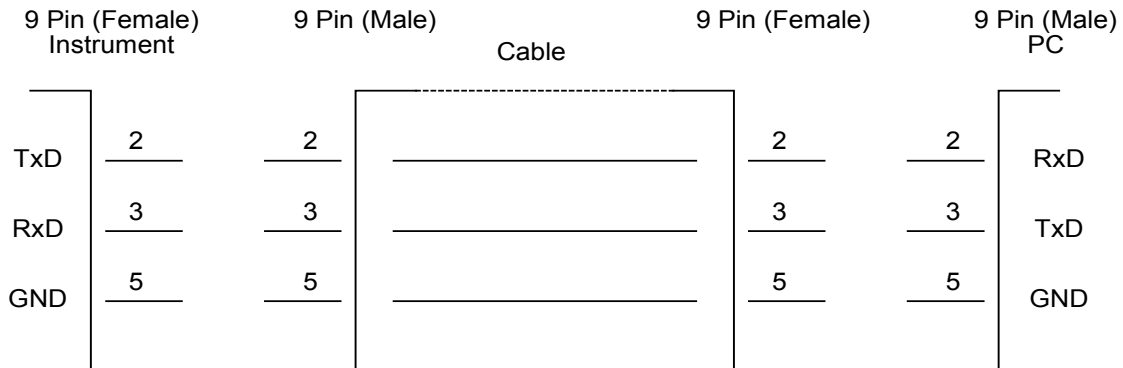

5.4 Remote Commands

5.4.1 Remote Command Summary

- **IEEE 488.2 Commands**

```
*CLS
*ESE < enable value >
*ESE?
*ESR?
*IDN?
*OPC
*OPC?
*PSC 0 | 1
*PSC?
*RST
*RCL < register number >
*SAV < register number >
*SRE < enable value >
*SRE?
*STB?
```

The SCPI (Standard Commands for Programmable Instruments) parameter syntax format is listed below:

- (1) The dual arrow symbol "< >" denotes the defined parameter is a standard SCPI command.
- (2) The symbol "< numeric value >" denotes the metric system value.
- (3) The symbol "< boolean >" denotes the Boolean equation data (its value is 0 or 1).
- (4) The vertical line "|" denotes the 'OR' parameter.
- (5) The symbol "< channel list >" denotes Scanner and Channel status: (@S(C1, C2...)) S denotes Scan number and C1, C2... denotes Channel number.

• SCPI Commands

```

:MEMory
|   :DELeTe
|   |   [:NAME]      < name >
|   |   :LOCAtion   < register number >
|   :STATe
|   |   :DEFine    < name >, < register number >
|   |   :DEFine?  < name >
|   :FREE
|   |   :STATe?
|   |   :STEP?
|   NSTates?
:SYSTem
|   :ERRor
|   |   [NEXT]?
|   :VERSion?
[:SOURce]
|   :SAFETy
|   |   :FETCh?   [ < item > ] [ , < item > ]
|   |   :START
|   |   |   [:ONCE]
|   |   |   :OFFSet   GET | OFF
|   |   |   :OFFSet?
|   |   |   :CSTandard GET
|   |   :STOP
|   |   :BCONTinue
|   |   :STATus?
|   |   :SNUMber?
|   |   :RESult
|   |   |   :ALL
|   |   |   |   [:JUDGment]?
|   |   |   |   [:JUDGement]?
|   |   |   |   :OMETerage?
|   |   |   |   :MMETerage
|   |   |   |   |   [:NORMAl]?
|   |   |   |   |   :LAC?
|   |   |   |   |   :LDC?
|   |   |   |   :MODE?
|   |   |   |   :TIME
|   |   |   |   |   [ELAPsed]
|   |   |   |   |   |   :RAMP?
|   |   |   |   |   |   |   [:TEST]?
|   |   |   |   |   |   |   :DWELL?
|   |   |   |   |   |   |   :FALL?
|   |   |   :COMPLeted?
|   |   |   [:LAST]
|   |   |   |   [:JUDGment]?
|   |   |   |   [:JUDGement]?
|   |   |   :AREPort < boolean > / ON / OFF (RS-232 Interface only)
|   |   |   :AREPort? (RS-232 Interface only)
|   |   |   |   :ITEM [ < item > ] [ , < item > ] (RS-232 Interface only)
|   |   |   |   :ITEM? (RS-232 Interface only)
|   |   |   ASAVe < boolean > / ON / OFF (RS-232 Interface only)
|   |   :STEP<n>
|   |   |   :DELeTe
|   |   |   :SET?
|   |   |   :MODE?

```

```

:GB
|
|
|
| :CURRent
|   | :OFFSet <numeric value>
|   | :OFFSet?
|   | [:LEVel] < numeric value >
|   | [:LEVel]?
|   | :LIMit
|   | | [:HIGH] < numeric value >
|   | | [:HIGH]?
|   | | :LOW < numeric value >
|   | | :LOW?
|   | :TIME
|   | | [:TEST] < numeric value >
|   | | [:TEST]?
|   | :TPORt < boolean > | ON | OFF
|   | :TPORt?
|   | :CHANnel
|   | | [:HIGH] < channel list >
|   | | [:HIGH]?
:AC
|
|
|
| :CURRent
|   | :OFFSet <numeric value>
|   | :OFFSet?
|   | [:LEVel] < numeric value >
|   | [:LEVel]?
|   | :LIMit
|   | | [:HIGH] < numeric value >
|   | | [:HIGH]?
|   | | :LOW < numeric value >
|   | | :LOW?
|   | | :ARC
|   | | | [:LEVel] < numeric value >
|   | | | [:LEVel]?
|   | | | :FILTer < numeric value >
|   | | | :FILTer?
|   | :TIME
|   | | :RAMP < numeric value >
|   | | :RAMP?
|   | | | [:TEST] < numeric value >
|   | | | [:TEST]?
|   | | | :FALL < numeric value >
|   | | | :FALL?
|   | :CHANnel
|   | | [:HIGH] < channel list >
|   | | [:HIGH]?
|   | | | :LOW < channel list >
|   | | | :LOW?
:DC
|
|
|
| :CURRent
|   | :OFFSet <numeric value>
|   | :OFFSet?
|   | | :FREQuency <numeric value>
|   | | :FREQuency?
|   | [:LEVel] < numeric value >
|   | [:LEVel]?
|   | :LIMit
|   | | [:HIGH] < numeric value >

```



```

:OSC
:CRANge? <MAXimun|MINimum|NOW>
:CURRent<m>
| :OFFSet <numeric value>
| :OFFSet?
:LIMit
| [:OPEN] < numeric value >
| [:OPEN]?
| :SHORT < numeric value >
| :SHORT?
:CHANnel
| [:HIGH] < channel list >
| [:HIGH]?
| :LOW < channel list >
| :LOW?
:CSTandard <range>,<numeric value>
:CSTandard?
:LC (6000-04, 6000-05,6000-06, 6000-07 and 6000-08 only)
:CURRent
| :OFFSet
| | [:LC] <numeric value>
| | [:LC]?
| | :LAC <numeric value> ( 6000-08 only )
| | :LAC? ( 6000-08 only )
| | :LDC <numeric value> ( 6000-08 only )
| | :LDC? ( 6000-08 only )
[:DEVice] UL1950 | UL1563 | UL544NP | UL544P | UL2601
| 1950-U1 |2601-U1 (1950-U1, 2601-U1 6000-08 only)
[:DEVice]?
:DISPlay RMS | PEAK ( 6000-08 only )
:DISPlay?
:LAC[:HIGH] <Range 0 ~ high limit, 0 means off> (6000-08 only)
:LAC[:HIGH]? (6000-08 only)
:LDC[:HIGH] <Range 0~1mA, if high limit is lower than 1mA, range
| is 0~high limit, 0 means off> (6000-08 only)
:LDC[:HIGH]? (6000-08 only)
:LINE NORmal | REVerse | SFNormal | SFReverse
:LINE?
:METER L | P, P | G (6000-05/07/08 only)
:METER? (6000-05/07/08 only)
:GSWItch < boolean > | ON | OFF (6000-05/07/08 only)
:GSWItch? (6000-05/07/08 only)
:LIMit
| [:HIGH] < numeric value >
| [:HIGH]?
| :LOW < numeric value >
| :LOW?
:TIME
| [:TEST] < numeric value >
| [:TEST]?
| :DWELI < numeric value >
| :DWELI?
:POWer
| :MODE VOLTage | CURRent | VA | SIMUlation | SOURce
| :MODE?
| :VOLTage
| | [:LIMit]

```



```

| | | :IEC <boolean > | ON | OFF
| | | :IEC?
| | | :RJUDgment <boolean > | ON | OFF
| | | :RJUDgment?
| | | :SCREen <boolean > | ON | OFF
:TRIGger:SOURce:EXTernal:STATe <boolean > | ON | OFF
:TRIGger:SOURce:EXTernal:STATe?

```

5.4.2 Remote Command Description

- **IEEE 488.2 Commands**

***CLS**

Clear Status

Clear standard event status register

Clear status bit group register except for MAV bit (bit 4).

***ESE < numeric value >**

Event Status Enable

Enable standard event status register value. <metric system value> range is 0 ~255.

***ESE?**

Event Status Enable Query

Query standard event status of device enable register. <metric system value> range is 0 ~255.

***ESR?**

Event Status Register Query

Query standard event register value of device. After this command, the standard event register is cleared to 0. <metric system value> range is 0 ~255.

***IDN?**

Identification Query

Query/Read basic device data (a comma separates the identification fields). It denotes the manufacturer, device model, serial number, and firmware version.

***OPC**

Operation Complete

Operation is complete.

***OPC?**

Operation Complete Query

Query Operation complete. The output format is ASCII character "1".

***PSC 0 | 1**

Power On

Clear status of Power On.

***PSC?**

Power On Query

Query Power On. The output format is ASCII character "1" or "0".

***RST**

Reset
The device reset command.

***RCL < numeric value >**

Recall
Recall command. Recalls the saved parameters.

***SAV < numeric value >**

Save
Save command. Saves the current parameters to memory.

***SRE < numeric value >**

Service Request Enable
Enable service request register value. <metric system value> range is 0 ~ 255.

***SRE?**

Service Request Enable Query
Query/Read service request register value. <metric system value> range is 0 ~255.

***STB?**

Status Byte Register Query
Query/Read status byte register value. <metric system value> range is 0 ~255.

- **SCPI Commands**

:MEMory:DELeTe[:NAME] < name >

This command deletes the parameter data of the <name> indicated in the main memory.

The < name > is character data.

Example: Input command "**MEM:DEL "123"**"

Description: This command deletes the parameter data of "123" in the main memory.

:MEMory:DELeTe:LOCAtion < register number >

This command deletes the parameter data of <register number> in the main memory.

< register number > is integer data.

Example: Input command "**MEM:DEL:LOCA 1**"

Description: This command deletes the first parameter data in the main memory.

:MEMory:STATe:DEFine < name >, < register number >

This command assigns the memory name of <register number> in the main memory.

Example: Input command "**MEM:STAT:DEF TEST,1**"

Description: This command assigns the parameter data name TEST to the first memory location in the main memory.

:MEMory:STATe:DEFine? < name >

This command queries the <register number> memory defined by <name>.

Example: Input command "**MEM:STAT:DEF? TEST**"

Return message "1"

Description: Return message "1" means the location of TEST parameter data is at the beginning.

:MEMory:FREE:STATe?

This command queries the next free PRESET parameter number in the main memory.

Example: Input command "**MEM:FREE:STAT?**"

Return message "**97, 3**"

Description: Return message "**97, 3**" means the parameter data number 97 can be set (three groups have already been used.)

:MEMory:FREE:STEP?

This command queries the next free step in main memory.

Example: Input command "**MEM:FREE:STEP?**"

Return message "**497, 3**"

Description: Return message "**497, 3**" means the next STEP, 497, can be set (three steps have already been used.)

:MEMory:NSTates?

This command queries the maximum value plus 1 of the analyzer *SAV / *RCL parameter can be used.

Example: Input command "**MEM:NST?**"

Return message "**101**"

Description: Return message "**101**" means the storage capacity of the main memory is 100 groups (101-1).

:SYSTem:ERRor[:NEXT]?

This command reads the message in the Error Queue.

(Refer to section 5.5 Error Message.)

Example: Input command "**SYST:ERR?**"

Return message "**+0, "No error"**"

Description: Return message "**+0, "No error"**" means there is no error message in the queue.

:SYSTem:VERSion?

This command queries the SCPI version of this device.

Example: Input command "**SYST:VERS?**"

Return message "**1990.0**"

Description: Return message "**1990.0**" means the device supported SCPI version is 1990.0.

[:SOURce]:SAFETy:FETCh? [*item* >] [, < *item* >]

This command queries the data for the current test. The < item > is character data. The command returns the following data:

Data	Return Data
STEP	The step number.
MODE	The test mode.
OMETerage	The current output value.
MMETerage	The measured value.
LACMETerage	The LAC value.
LDCMETerage	The LDC value.

RELapsed	The ramp elapsed time.
RLEAve	The time left in the ramp cycle
DELapsed	The dwell elapsed time.
DLEAve	The time left in the dwell cycle.
TELapsed	The elapsed time of test. Return the leave time when Test Time is limited. Return 9.9000001E+37 when Test Time is CONT.
TLEAve	The time left in the test cycle. Return the leave time when Test Time is limited. Return 9.9000001E+37 when Test Time is CONT.
FELapsed	The current elapsed Fall Time.
FLEAve	The current remaining Fall Time.
CHANnel	The current Channel.

Example: Input command **"SAFE: FETH?"STEP, MODE, OMET**
Return message **"1, AC, +5.000000E+02"**

Description: Return message **"1, AC, +5.000000E+02"** means the current STEP, MODE, and output values are set to STEP1, AC MODE and 0.500kV.

[[:SOURce]:SAFety:START[:ONCE]

This command is for starting the test.

Example: Input command **"SAFE:STAR"**

Description: This command starts the test.

[[:SOURce]:SAFety:START:OFFSet GET | OFF

This command gets the offset value when the parameter is GET and turns off the offset function when the parameter is OFF.

Example: Input command **"SAFE:STAR OFFS GET"**

Description: This command gets the offset value.

Example: Input command **"SAFE:STAR OFFS OFF"**

Description: This command turns the offset function off.

[[:SOURce]:SAFety:START:OFFSet?

This command queries if the offset function is ON or OFF

Example: Input command **"SAFE:STAR OFFS?"**

Return message **"0"**

Description: Return message **"0"** means the analyzer is not using the offset function

[[:SOURce]:SAFety: START: CSTandard GET

This command triggers the unit to get the Cs value

Example: Input command **"SAFE: STAR: CST GET"**

Description: This command starts the GET Cs function for the open/short circuit detection mode. A known good DUT must be connected when this command is sent.

[[:SOURce]:SAFety:STOP

This command is for stopping the test.

Example: Input command **"SAFE:STOP"**

Description: This command stops the analyzer test.

:SOURCE]:SAFETY:BCONTINUE

This command is able to interrupt the step testing when the TEST TIME of the testing step is set to CONTINUE.

Example: Input command "**SAFE:BCON**"

Description: It interrupts the step testing.

[:SOURCE]:SAFETY:STATUS?

This command queries the execution status of the current device under test. The returned character data is either RUNNING or STOPPED.

Example: Input command "**SAFE:STAT?**"

Return message "**RUNNING**"

Description: Return message "**RUNNING**" means the analyzer is running the test.

[:SOURCE]:SAFETY:SNUMBER?

This command queries how many steps have been set in the memory.

Example : Input command "**SAFE:SNUM?**"

Return message "**+2**"

Description: Return message "**+2**" means 2 steps in the main memory have been set.

[:SOURCE]:SAFETY:RESULT:ALL:OMETERAGE?

This command queries all the voltage (OUTPUT METER) readings for the step.

Example : Input command "**SAFE:RES:ALL:OMET?**"

Return message "**5.100000E+01**"

Description: Return message "**5.100000E+01**" means the query OUTPUT METER returned a value of 0.051kV.

[:SOURCE]:SAFETY:RESULT:ALL:MMETERAGE[:NORMAL]?

This command queries all the MEASURE METER readings for the step.

Example : Input command "**SAFE:RES:ALL:MMET?**"

Return message "**7.000000E-05**"

Description: Return message "**7.000000E-05**" means the query MEASURE METER returned a value of 0.07mA.

[:SOURCE]:SAFETY:RESULT:ALL:MMETERAGE:LAC?

This command queries all the MEASURE METER LAC readings for the step.

Example : Input command "**SAFE:RES:ALL:MMET:LAC?**"

Return message "**1.000000E-04**"

Description: Return message "**1.000000E-04**" means the query MEASURE METER LAC returned a value of 0.10mA.

[:SOURCE]:SAFETY:RESULT:ALL:MMETERAGE:LDC?

This command queries all the MEASURE METER LDC readings for the step.

Example : Input command "**SAFE:RES:ALL:MMET:LDC?**"

Return message "**1.000000E-04**"

Description: Return message "**1.000000E-04**" means the query MEASURE METER LDC returned a value of 0.10mA.

[:SOURCE]:SAFETY:RESULT:ALL:MODE?

This command queries the MODE of all steps. The returned format is:

AC|DC|GB|IR|LC|PA|OSC.

Example: Input command "**SAFE:RES:ALL:MODE?**"

Return message "**DC**"

Description: Return message "**DC**" means the unit is set to test mode DC.

[[:SOURce]:SAFETy:RESult:ALL:TIME[:ELAPsed]:RAMP?

This command queries elapse time of ramp of all steps.

Example : Input command **"SAFE:RES:ALL:TIME: RAMP?"**

Return message **"1.000000E+00"**

Description: Return message **"1.000000E+00"** means ramp to the setting voltage time is 1 second.

[[:SOURce]:SAFETy:RESult:ALL:TIME[:ELAPsed][:TEST]?

This command queries the test time of all steps.

Example : Input command **"SAFE:RES:ALL:TIME?"**

Return message **"3.000000E+00"**

Description : Return message **"3.000000E+00"** means the test needed time result is 3 seconds.

[[:SOURce]:SAFETy:RESult:ALL:TIME[:ELAPsed]:DWELI?

This command queries the test dwell time of all steps.

Example : Input command **"SAFE:RES:ALL:TIME:DWEL?"**

Return message **"2.500000E+00"**

Description: Return message **"2.500000E+00"** means the test dwell time is 2.5 seconds.

[[:SOURce]:SAFETy:RESult:ALL:TIME[:ELAPsed]:FALL?

This command queries the test fall time of all steps.

Example : Input command **"SAFE:RES:ALL:TIME:FALL?"**

Return message **"2.500000E+00"**

Description: Return message **"2.500000E+00"** means the test fall time is 2.5 seconds.

[[:SOURce]:SAFETy:RESult:ALL[:JUDGment]?

This command queries the judgment results of all steps. Return formats are:

First Step Result, Second Step, Result..., Last Step Result.

Code meaning list:

Mode	GB		AC		DC		IR		LC		OSC		ALL	
	HEX	DEC	HEX	DEC	HEX	DEC	HEX	DEC	HEX	DEC	HEX	DEC	HEX	DEC
STOP													70	112
USER STOP													71	113
CAN NOT TEST													72	114
TESTING													73	115
PASS													74	116
HIGH FAIL	11	17	21	33	31	49	41	65	51	81				
LOW FAIL	12	18	22	34	32	50	42	66	52	82				
ARC FAIL			23	35	33	51								
HIGH FAIL			24	36	34	52			54	84	64	100		
CHECK FAIL					35	53								
OUTPUT A/D OVER	16	22	26	38	36	54	46	70	56	86	66	102		
METER A/D OVER	17	23	27	39	37	55	47	71	57	87	67	103		
CURR FAIL	18	24												
POWER HIGH FAIL									58	88				

POWER LOW FAIL									59	89				
SHORT FAIL											61	97		
OPEN FAIL											62	98		

Example : Input command "**SAFE:RES:ALL?**"
 Return message "**116**"
 Description : Return message "**116**" means judgment result is pass.

[[:SOURce]:SAFety:RESult:COMPlated?

This command queries if all the test results are completed. Returns 1 or 0.

Example: Input command "**SAFE:RES:COMP?**"

Return message "**1**"

Description: Return message "**1**" means all of the test results are completed.

[[:SOURce]:SAFety:RESult[:LAST][:JUDGment]?

This command queries the judgment result code of the last step.

Example: Input command "**SAFE:RES:LAST?**"

Return message "**116**"

Description: This command means the judgment result of the last step is pass.

[[:SOURce]:SAFety:RESult:AREPort < boolean > | ON | OFF

This command sets the automatic reporting of the test results (RS-232 Interface only).

Example: Input command "**SAFE:RES:AREP ON**"

Description: The analyzer auto reports the test result after the test is completed.

[[:SOURce]:SAFety:RESult:AREPort?

This command queries if the Automatic Reporting of test results is ON or OFF. Returns 1 or 0 (RS-232 interface only).

Example: Input command "**SAFE:RES:AREP?**"

Return message "**1**"

Description: Return message "**1**" means auto report test result after the analyzer test is completed is "ON".

[[:SOURce]:SAFety:RESult:AREPort:ITEM [< item >] [, < item >]

Sets test data for auto report; < item > is for character data (meaning is listed below):

Character Data	Returned Data
MODE	Measurement MODE.
OMETerge	Output value
MMETerge	Measurement value
LACMETerge	LAC measurement value
LDCMETerge	LDC measurement value
RELapsed	The elapsed time for Ramp.
DELapsed	The elapsed time for Dwell.
TELapsed	The elapsed time for Test. When Test Time is set to CONT. and Test Time is higher than 999sec, it responds 9.9000001E+37.
FELapsed	The elapsed time for Fall Time.
STATE	The test result code

The sequence for report data is:

MODE, OMETerage, MMETerage, LACMETerage, LDCMETerage, RELApsed, DELApsed, TELApsed, FELApsed, STATe

Example: 1. Input command "**SAFE: RES: AREP ON**". Sets auto reporting "ON".

2. Input command "**SAFE: RES: AREP: ITEM STAT, MODE, OMET**".

Sets the data to be reported. It assumed the test as AC

MODE, then return message is as below. AC, +5.200000E+01, 116

Description: When the test is done, it will follow the setting to report the data.

Note: It is no need to set the parameters in sequence; however, the data will report sequentially.

[[:SOURce]:SAFEty:RESult:AREPort:ITEM?

Queries data item of device auto report test as well as returns data report item.

(RS-232 interface only)

Example: Input command "**SAFE:RES:AREP:ITEM?**"

Return message "MODE,OMET,STAT"

Description: The return message presents "Measurement MODE", "Output value" and "Test result code".

SOURce:SAFEty:RESult:ASAVe < boolean > | ON | OFF

This command sets the auto report function to "ON" or "OFF" at the next power on.

(RS-232 interface only)

Example: Input command "**SOUR:SAFE:RES:ASAV ON**"

Description: The auto report function is set to "ON" at the next power on.

SOURce:SAFEty:RESult:ASAVe?

Queries the device if the auto report function is active at the next power on.

Example: Input command "**SOUR:SAFE:RES:ASAV?**"

Description: It returns "1" if the auto report function is active the next power on.

[[:SOURce]:SAFEty:STEP<n>:DELete

This command deletes step <n> and the step behind <n> will fill in the vacancy.

Example: Input command "**SAFE:STEP 1:DEL**"

Description: This command deletes step 1 setting value in the main memory.

[[:SOURce]:SAFEty:STEP<n>:SET?

This command queries all setting values in the selected step.

Example : Input command **SAFE:SETP 1:SET?**

Return message 1, AC, 5.000000E+03, 6.000000E-04,
7.000000E-06, 8.000000E-03, 2.300000E+05, 3.000000E+00,
1.000000E+00, 2.000000E+00, 6.000000E+01, (0),(0)

Description: This command means STEP setting value is STEP 1, AC, VOLT: 5.000kV, HIGH: 0.600mA, LOW: 0.007mA, ARC: 8.0mA, ARC FILTER: 230kHz, TIME: 3.0s, RAMP: 1.0s, FALL: 2.0s, FREQ: 60Hz, SCAN BOX: OFF.

[[:SOURce]:SAFEty:STEP<n>:MODE?

This command queries the test Mode of the selected step.

The return format is: GB | AC | DC | IR | OSC | PA.

Example: Input command "**SAFE:RES:ALL:MODE?**"

Return message "DC"

Description: Return message "DC" means the mode is DC.

[[:SOURce]:SAFety:STEP<n>:GB:CURRent:OFFSet <numeric value>

This command sets the Offset value of the ground bond test for the selected step.

Parameter **<numeric value>**: Offset value of ground bond test in ohms (Ω).

Range: 0.000 ~ 0.5000

Example: Input command "**SAFE:STEP1:GB:CURR:OFFS 0.1**"

Description: This command sets the Offset value of the ground bond test in STEP 1 to 100m Ω .

[[:SOURce]:SAFety:STEP<n>:GB:CURR:OFFSet?

This command queries the Offset value of the ground bond test for the selected step.

Example: Input command "**SAFE:STEP1:GB:CURR:OFFS?**"

Return message "**+1.000000E-01**"

Description: Return message "**+1.000000E-01**" means the Offset value for the ground bond test in STEP 1 is 100m Ω .

[[:SOURce]:SAFety:STEP<n>:GB[:LEVel] < numeric value >

This command sets the grounding resistance test current value in amperes (A) for the selected step.

Range : The range can be set as follows:

1. 30:30 : 1 ~30
2. 30:40 : 1 ~40
3. 30:45 : 1 ~45
4. 30:60 : 1 ~60

Example : Input command "**SAFE:STEP1:GB 5**"

Description : This command sets the step 1 current value to 5A.

[[:SOURce]:SAFety:STEP<n>:GB[:LEVel]?

This command queries the grounding resistance test current value for the selected step.

Example : Input command "**SAFE:STEP:GB?**"

Return message "**+5.000000E+00**"

Description : Return message "**+5.000000E+00**" means the current value of the grounding resistance test is 5A.

[[:SOURce]:SAFety:STEP<n>:GB:LIMit[:HIGH] < numeric value >

This command sets the grounding resistance high limit value in Ohms for the selected step.

Range : 0.0001 ~ 0.51 (the high limit value of grounding resistance x current value should be $\leq 6.3V$)

Example : Input command "**SAFE:STEP1:GB:LIM 0.11**"

Description : This command sets the step 1 grounding resistance high limit value to 0.11 ohm.

[[:SOURce]:SAFety:STEP<n>:GB:LIMit[:HIGH]?

This command queries the grounding resistance high limit value for the selected step.

Example : Input command "**SAFE:STEP:GB:LIM?**"

Return message "**+1.100000E-01**"

Description : Return message "**+1.100000E-01**" means the grounding resistance high limit value is 0.11 ohm.

[[:SOURce]:SAFETy:STEP<n>:GB:LIMit:LOW

This command sets the grounding resistance low limit value in Ohms for the selected step.

Range : 0.0001 ~0.51 (the low limit value of grounding resistance should be ≤ the high limit value)

Example : Input command "**SAFE:STEP1:GB:LIM:LOW 0.01**"

Description : This command sets the step 1 grounding resistance low limit value to 0.01 ohm.

[[:SOURce]:SAFETy:STEP<n>:GB:LIMit:LOW?

This command queries the grounding resistance low limit value for the selected step.

Example : Input command "**SAFE:STEP:GB:LIM:LOW?**"
Return message "**+1.000000E-02**"

Description : Return message "**+1.000000E-02**" means the grounding resistance low limit value is 0.01 ohm.

[[:SOURce]:SAFETy:STEP<n>:GB:TIME[:TEST] < numeric value >

This command sets the test time in seconds for the selected step.

Range : 0 or 0.3~999.0 (0=CONTINUOUS)

Example : Input command "**SAFE:STEP1:GB:TIME 0.5**"

Description : This command sets the step 1 test time to 0.5 seconds.

[[:SOURce]:SAFETy:STEP<n>:GB:TIME[:TEST]?

This command queries the test time for the selected step.

Example : Input command "**SAFE:STEP:GB:TIME?**"
Return message "**+5.000000E-01**"

Description : Return message "**+5.000000E-01**" means the test time is 0.5 seconds.

[[:SOURce]:SAFETy:STEP<n>:GB:TPORT < boolean > | ON | OFF

This command enables or disables the twin port function (ON or OFF).

Example : Input command "**SAFE:STEP1:GB:TROP ON**"

Description : This command sets the step 1 twin port function ON.

[[:SOURce]:SAFETy:STEP<n>:GB:TPORT?

This command queries the twin port function for the selected step.

Example : Input command "**SAFE:STEP:GB:TROP?**"
Return message "**1**"

Description : Return message "**1**" means the step 1 twin port output function is ON.

[[:SOURce]:SAFETy:STEP<n>:GB:CHANnel[:HIGH] < channel list >

This command sets the high scan channels for the selected step. The <channel list> format is: (@SN(C1, C2, C3)). SN is the scan box number; C1, C2, and C3 are the channel numbers.

Example : Input command "**SAFE:STEP1:GB:CHAN(@2(1,2))**"

Description : This command sets the high scan channel in STEP 1 to BOX 2 channel 1 and 2 HIGH output.

Example : Input command "**SAFE:STEP1:GB:CHAN(@2(0))**"

Description : This command means the BOX 2 high scan channel in STEP 1 is set to OFF.

[[:SOURce]:SAFety:STEP<n>:GB:CHANnel[:HIGH]?]

This command queries the high scan channels for the selected step.

Example : Input command "**SAFE:STEP1:AC:CHAN?**"

Return message "**(@2(1,2))**"

Description : Return message "**(@2(1,2))**" means the high scan channel in STEP 1 is set to BOX 2 channel 1 and 2 HIGH output.

[[:SOURce]:SAFety:STEP<n>:AC:CURREnt>:OFFSet <numeric value>]

This command sets the Offset value of the AC withstand test of the selected step.

Parameter **<numeric value>**: The Offset value of the AC withstand test in Amperes (A).

Range: The Offset range is 0.000000~0.002999 when High Limit range is from 0.001 to 2.999mA.

The Offset range is 0.00000~0.04000 when High Limit range is from 3 to 40mA.

Example: Input command "**SAFE:STEP2:AC:CURR:OFFS 0.0001**".

Description: Sets the Offset value of the AC withstand test in Step 2 of the analyzer to 0.1mA.

[[:SOURce]:SAFety:STEP<n>:AC:CURR:OFFSet?]

This command queries the Offset value of the AC withstand test of the selected step.

Example: Input command "**SAFE:STEP2:AC:CURR:OFFS?**".

Return message "**+1.000000E-04**"

Description: Return message "**+1.000000E-04**" means the Offset value of the AC withstand test in Step 1 is 0.1mA.

[[:SOURce]:SAFety:STEP<n>:AC:FREQuency <numeric value>]

This command sets the test frequency of the AC withstand test for the selected step.

Parameter **<numeric value>**: The test frequency of the AC withstand test in Hertz (Hz).

Range: 0 or 50~600Hz (0=DEFAULT). When the setting is 0, the output frequency is set by the AC Freq. setting under PRESET.

Example: Input command "**SAFE:STEP2:AC:FREQ 60**".

Description: Sets the frequency of the AC withstand test in Step 2 of the main unit to 60Hz.

[[:SOURce]:SAFety:STEP<n>:AC:FREQuency?]

This command queries the test frequency of the AC withstand test for the selected step.

Example: Input command "**SAFE:STEP2:AC:FREQ?**".

Return message "**+6.000000E+01**"

Description: Return message "**+6.000000E+01**" means the test frequency of the AC withstand test in Step 2 is 60Hz.

[[:SOURce]:SAFety:STEP<n>:AC[:LEVel]< numeric value >]

This command sets the AC withstand voltage level in volts (V) for the selected step.

Range: 50~5000

Example: Input command "**SAFE:STEP2:AC 3000**".

Description: Sets the AC withstand voltage level in STEP 2 to 3000V.

[[:SOURce]:SAFEty:STEP<n>:AC[:LEVel]?

This command queries the AC withstand voltage level for the selected step.

Example: Input command "**SAFE:STEP2:AC?**"

Return message "**3.000000E+03**"

Description: Return message "**3.000000E+03**" means the voltage in Step 2 of the AC withstand voltage test is 3000V.

[[:SOURce]:SAFEty:STEP<n>:AC:LIMit[:HIGH] < numeric value >

This command sets the AC withstand voltage leakage current high limit in amperes (A) for the selected step.

Range: 0.000001~0.04

Example: Input command "**SAFE:STEP2:AC:LIM 0.01**"

Description: This command sets the AC withstand voltage leakage current high limit in STEP 2 to 10mA.

[[:SOURce]:SAFEty:STEP<n>:AC:LIMit[:HIGH]?

This command queries the AC withstand voltage leakage current high limit value for the selected step.

Example : Input command "**SAFE:STEP2:AC:LIM?**"

Return message "**1.000000E-02**"

Description: Return message "**1.000000E-02**" means the AC withstand voltage leakage current high limit value in STEP 2 is 10mA.

[[:SOURce]:SAFEty:STEP<n>:AC:LIMit:LOW < numeric value >

This command sets the AC withstand voltage leakage current low limit value for the selected step.

Example : Input command "**SAFE:STEP2:AC:LIM:LOW 0.00001**"

Description: This command sets the AC withstand voltage leakage current low limit value in STEP 2 to 0.01mA.

[[:SOURce]:SAFEty:STEP<n>:AC:LIMit:LOW?

This command queries the AC withstand voltage leakage current low limit value for the selected step.

Range : 0.000001~0.04 (low limit value of leakage current ≤ setting high limit value)

Example : Input command "**SAFE:STEP2:AC:LIM:LOW?**"

Return message "**1.000000E-05**"

Description: Return message "**1.000000E-05**" means the AC withstand voltage leakage current low limit value in STEP 2 is 0.01mA.

[[:SOURce]:SAFEty:STEP<n>:AC:LIMit:ARC[:LEVel] < numeric value >

This command sets the arc current limit in amperes (A) for the selected step.

Range : 0 or 0.0010~0.0300 (0=OFF).

Example : Input command "**SAFE:STEP2:AC:LIM:ARC 0.004**"

Description: This command sets the arc current limit in STEP 2 to 4mA.

[[:SOURce]:SAFEty:STEP<n>:AC:LIMit:ARC[:LEVel]?

This command queries the arc current limit for the selected step.

Example : Input command "**SAFE:STEP2:AC:LIM:ARC?**"

Return message "**4.000000E-03**"

Description: Return message "**4.000000E-03**" means the arc current limit in STEP 2 is 4.0mA.

[[:SOURce]:SAFety:STEP<n>:AC:LIMit:ARC:FILTer < numeric value >

This command sets the arc filter in Hertz (Hz) for the selected step.

Range : ARC bandwidth 23 kHz = 2.300000E+04
ARC bandwidth 50 kHz = 5.000000E+04
ARC bandwidth 100 kHz = 1.000000E+05
ARC bandwidth 230 kHz = 2.300000E+05

Example : Input command "**SAFE:STEP2:AC:LIM:ARC:FILT 230000**"

Description : This command sets the arc filter in STEP 2 to 230000Hz (230kHz).

[[:SOURce]:SAFety:STEP<n>:AC:LIMit:ARC:FILTer?

This command queries the arc filter for the selected step.

Example: Input command "**SAFE:STEP2:AC:LIM:ARC:FILT?**"

Return message "**2.300000E+05**"

Description: Return message "**2.300000E+05**" means the arc filter in STEP 2 is 230000Hz (230kHz).

[[:SOURce]:SAFety:STEP<n>:AC:TIME:RAMP < numeric value >

This command sets the ramp time in seconds (s) for the selected step.

Range : 0 or 0.1~999.0 (0=OFF).

Example : Input command "**SAFE:STEP2:AC:TIME:RAMP 5**"

Description: This command sets the ramp time in STEP 2 to 5.0sec.

[[:SOURce]:SAFety:STEP<n>:AC:TIME:RAMP?

This command queries the ramp time for the selected step.

Example: Input command "**SAFE:STEP2:AC:TIME:RAMP?**"

Return message "**5.000000E+00**"

Description: Return message "**5.000000E+00**" means the ramp time in STEP 2 is 5.0sec.

[[:SOURce]:SAFety:STEP<n>:AC:TIME[:TEST] < numeric value >

This command sets the test time in seconds (s) for the selected step.

Range: 0 or 0.3~999.0, 0 is for setting CONTINUE

Example: Input command "**SAFE:STEP2:AC:TIME 10**"

Description: This command sets the test time in STEP 2 to 10.0sec.

[[:SOURce]:SAFety:STEP<n>:AC:TIME[:TEST]?

This command queries the test time for the selected step.

Example: Input command "**SAFE:STEP2:AC:TIME?**"

Return message "**1.000000E+01**"

Description: Return message "**1.000000E+01**" means the test time in STEP 2 is 10.0sec.

[[:SOURce]:SAFety:STEP<n>:AC:TIME:FALL < numeric value >

This command sets the time required for the voltage to fall to 0 in seconds (s) for the selected step.

Range: 0 or 0.1~999.0 (0=OFF).

Example: Input command "**SAFE:STEP2:AC:TIME:FALL 3**"

Description: This command sets the time required for the voltage to fall to 0 for STEP 2 to 3.0sec.

[[:SOURce]:SAFety:STEP<n>:AC:TIME:FALL?

This command queries the time required for the voltage to fall to 0 for the selected step.

Example: Input command **"SAFE:STEP2:AC:TIME:FALL?"**

Return message **"3.000000E+00"**

Description: Return message **"3.000000E+00"** means the time required for the voltage to fall to 0 in STEP 2 is 3.0sec..

[[:SOURce]:SAFety:STEP<n>:AC:CHANnel[:HIGH] < channel list >

This command sets the high scan channels for the selected step. The <channel list> format is: (@SN(C1, C2, C3)). SN is the scan box number; C1, C2, and C3 are the channel numbers.

Example: Input command **"SAFE:STEP2:AC:CHAN(@2(1,2))"**

Description: This command sets the high scan channel in STEP 2 to BOX 2 channel 1 and 2 HIGH output.

Example: Input command **"SAFE:STEP2:AC:CHAN(@2(0))"**

Description: This command means the BOX 2 high scan channel in STEP 2 is set to OFF.

[[:SOURce]:SAFety:STEP<n>:AC:CHANnel[:HIGH]?]

This command queries the high scan channels for the selected step.

Example: Input command **"SAFE:STEP2:AC:CHAN?"**

Return message **"(@2(1,2))"**

Description: Return message **"(@2(1,2))"** means the high scan channel in STEP 2 is set to BOX 2 channel 1 and 2 HIGH output.

[[:SOURce]:SAFety:STEP<n>:AC:CHANnel:LOW < channel list >

This command sets the low scan channels for the selected step (RTN/LOW).

Example: Input command **"SAFE:STEP2:AC:CHAN:LOW (@2(2,4))"**

Description: This command means the low scan channels in STEP 2 are set to BOX 2 channel 2 and 4 LOW output.

Example: Input command **"SAFE:STEP2:AC:CHAN:LOW (@2(0))"**

Description: This command sets the low scan channel in STEP 2 to OFF.

[[:SOURce]:SAFety:STEP<n>:AC:CHANnel:LOW?]

This command queries the low scan channels for the selected step.

Example: Input command **"SAFE:STEP2:AC:CHAN:LOW?"**

Return message **"(@2(2,4))"**

Description: Return message **"(@2(2,4))"** means the low scan channels in STEP 2 are BOX 1 channel 2 and 4 LOW output.

[[:SOURce]:SAFety:STEP<n>:DC:CURRent:OFFSet <numeric value>

This command sets the Offset value of the DC withstand test for the selected step.

Parameter **<numeric value>**: The Offset value of the DC withstand test in Amperes (A).

Range: The Offset range is 0.0000000~0.0002999 when the High Limit range is from 0.1uA to 299.9uA.

The Offset range is 0.000000~0.002999 when the High Limit range is from 0.3mA to 2.999mA.

The Offset range is 0.000000~0.01200 when the High Limit range is from 3mA to 12mA.

Example: Input command **"SAFE:STEP2:DC:CURR:OFFS 0.00001"**

Description: This command sets the Offset value of the DC withstand test in Step 2 to 10uA.

[[:SOURce]:SAFety:STEP<n>:DC:CURR:OFFSet?

This command queries the Offset value of the DC withstand test for the selected step.

Example: Input command "**SAFE: STEP2: DC: CURR: OFFS?**"

Return message "**+1.000000E-05**"

Description: Return message "**+1.000000E-05**" means the Offset value of the DC withstand test in Step 1 is set to 10uA.

[[:SOURce]:SAFety:STEP<n>:DC[:LEVel] < numeric value >

This command sets the DC voltage level in volts (V) for the selected step.

Range: 50~6000

Example: Input command "**SAFE:STEP3:DC 4000**"

Description: This command sets the DC voltage level for STEP 3 to 4000V.

[[:SOURce]:SAFety:STEP<n>:DC[:LEVel]?

This command queries the DC voltage level for the selected step.

Example: Input command "**SAFE:STEP3:DC?**"

Return message "**4.000000E+03**"

Description: Return message "**4.000000E+03**" means the DC voltage level for STEP 3 is set to 4000V.

[[:SOURce]:SAFety:STEP<n>:DC:LIMit[:HIGH] < numeric value >

This command sets the DC withstand voltage leakage current high limit value in amperes (A) for the selected step.

Range: 0.0000001~0.012

Example: Input command "**SAFE:STEP3:DC:LIM 0.002999**"

Description: This command sets the DC withstand voltage leakage current high limit value in STEP 3 to 2.999mA.

[[:SOURce]:SAFety:STEP<n>:DC:LIMit[:HIGH]?

This command queries the DC withstand voltage leakage current high limit value for the selected step.

Example: Input command "**SAFE:STEP3:DC:LIM?**"

Return message "**2.999000E-03**"

Description: Return message "**2.999000E-03**" means the DC withstand voltage leakage current high limit value in STEP 3 is set to 2.999mA.

[[:SOURce]:SAFety:STEP<n>:DC:LIMit:LOW < numeric value >

This command sets the DC withstand voltage leakage current low limit value in amperes (A) for the selected step.

Range: 0.0000001~0.012 (low limit value of leakage current \leq high limit value)

Example: Input command "**SAFE:STEP3:DC:LIM:LOW 0.000001**"

Description: This command sets the DC withstand voltage leakage current low limit value in STEP 3 to 0.001mA.

[[:SOURce]:SAFety:STEP<n>:DC:LIMit:LOW?

This command queries the DC withstand voltage leakage current low limit value for the selected step.

Example: Input command "**SAFE:STEP3:DC:LIM:LOW?**"

Return message "**1.000000E-06**"

Description: Return message "**1.000000E-06**" means the DC withstand voltage leakage current in STEP 3 is set to 0.001mA.

[[:SOURce]:SAFEty:STEP<n>:DC:LIMit:ARC[:LEVel] < numeric value >

This command sets the arc current limit value in amperes (A) for the selected step.
Range: 0 or 0.0010~0.0300 (0=OFF.)

Example: Input command "**SAFE:STEP3:DC:LIM:ARC 0.0025**"

Description: This command sets the arc current limit in STEP 3 to 2.5mA.

[[:SOURce]:SAFEty:STEP<n>:DC: LIMit:ARC[:LEVel]?

This command queries the arc current limit value for the selected step.

Example: Input command "**SAFE:STEP3:DC:LIM:ARC?**"

Return message "**2.500000E-03**"

Description: Return message "**2.500000E-03**" means the arc current limit in STEP 3 is set to 2.5mA.

[[:SOURce]:SAFEty:STEP<n>:DC:LIMit:ARC:FILTer < numeric value >

This command sets the arc filter for the selected step.

Range: ARC bandwidth 23 kHz = 2.300000E+04

ARC bandwidth 50 kHz = 5.000000E+04

ARC bandwidth 100 kHz = 1.000000E+05

ARC bandwidth 230 kHz = 2.300000E+05

Example: Input command "**SAFE: STEP3: AC: LIM: ARC: FILT 230000**"

Description: This command sets the arc filter for STEP 3 to 230000Hz (230kHz).

[[:SOURce]:SAFEty:STEP<n>:DC: LIMit:ARC:FILTer?

This command queries the arc filter for the selected step.

Example: Input command "**SAFE:STEP3:AC:LIM:ARC:FILT?**"

Return message "**2.300000E+05**"

Description: Return message "**2.300000E+05**" means the arc filter for STEP 3 is set to 230000Hz (230kHz).

[[:SOURce]:SAFEty:STEP<n>:DC:TIME:DWELl < numeric value >

This command sets the dwell time in seconds (s) for the selected step.

Range: 0 or 0.1~999.0 (0=CONTINUOUS)

Example: Input command "**SAFE: STEP3: DC: TIME: DWEL 2.5**"

Description: This command sets the dwell time for STEP 3 to 2.5 sec.

[[:SOURce]:SAFEty:STEP<n>:DC:TIME:DWELl?

This command queries the dwell time for the selected step.

Example: Input command "**SAFE: STEP3: DC: TIME: DWEL?**"

Return message "**2.500000E+00**"

Description: Return message "**2.500000E+00**" means the dwell time for STEP 3 is set to 2.5 sec.

[[:SOURce]:SAFEty:STEP<n>:DC:TIME:RAMP < numeric value >

This command sets the ramp time step in seconds (s) for the selected.

Range: 0 or 0.1~999.0, 0 is for setting OFF

Example: Input command "**SAFE: STEP3: DC: TIME: RAMP 2**"

Description: This command sets the ramp time for STEP 3 to 2.0 sec.

[[:SOURce]:SAFEty:STEP<n>:DC:TIME:RAMP?

This command queries the ramp time for the selected step.

Example: Input command "**SAFE: STEP3: DC: TIME: RAMP?**"

Return message "**2.000000E+00**"

Description: Return message "2.000000E+00" means the ramp time for STEP 3 is set to 2.0 sec.

[[:SOURce]:SAFETy:STEP<n>:DC:TIME[:TEST] < numeric value >

This command sets the test time in seconds (s) for the selected step.

Range: 0 or 0.1~999.0 (0=CONTINUOUS)

Example: Input command "SAFE:STEP3:DC:TIME 1"

Description: This command sets the test time for STEP 3 to 1.0sec.

[[:SOURce]:SAFETy:STEP<n>:DC:TIME[:TEST]?

This command queries the test time for the selected step.

Example: Input command "SAFE:STEP3:DC:TIME?"

Return message "1.000000E+00"

Description: Return message "1.000000E+00" means the test time for STEP 3 is set to 1 sec.

[[:SOURce]:SAFETy:STEP<n>:DC:TIME:FALL < numeric value >

This command sets the time required for the voltage to fall to 0 in seconds (s) for the selected step.

Range: 0 or 0.1~999.0 (0=OFF)

Example: Input command "SAFE:STEP3:DC:TIME:FALL 3"

Description: This command sets the time required for the voltage to fall to 0 for STEP 3 to 3.0sec.

[[:SOURce]:SAFETy:STEP<n>:DC:TIME:FALL?

This command queries the time required for the voltage to fall to 0 for the selected step.

Example: Input command "SAFE:STEP3:DC:TIME:FALL?"

Return message "3.000000E+00"

Description: Return message "3.000000E+00" means the time required for the voltage to fall to 0 for STEP 3 is set to 3.0sec.

[[:SOURce]:SAFETy:STEP<n>:DC:CHANnel[:HIGH] < channel list >

This command sets the high scan channels for the selected step. The <channel list> format is: (@SN(C1, C2, C3)). SN is the scan box number; C1, C2, and C3 are the channel numbers.

Example: Input command "SAFE: STEP3: DC:CHAN(@2(1,2))"

Description: This command sets the high scan channels for STEP 3 to BOX 2 channel 1 and 2 HIGH output.

Example: Input command "SAFE: STEP3: DC:CHAN(@2(0))"

Description: This command sets the high scan channels for STEP 3 to BOX 2 high scan channel OFF.

[[:SOURce]:SAFETy:STEP<n>:DC:CHANnel[:HIGH]?

This command queries the high scan channels for the selected step.

Example: Input command "SAFE: STEP3: DC: CHAN?"

Return message "@2(1,2)"

Description: Return message "@2(1,2)" means the high scan channels for STEP 3 is set to BOX 2 channel 1 and 2 to HIGH output.

[[:SOURce]:SAFETy:STEP<n>:DC:CHANnel:LOW < channel list >

This command sets the low scan channels for the selected step (RTN/LOW).

Example: Input command "SAFE:STEP3:DC:CHAN:LOW (@2(2,4))"

Description: This command sets the low scan channels for STEP 3 to BOX 2 channel 2 and 4 LOW output.

Example: Input command "**SAFE:STEP3:DC:CHAN:LOW (@2(0))**"

Description: This command sets the low scan channels for STEP 3 to OFF.

[[:SOURce]:SAFEty:STEP<n>:DC:CHANnel:LOW?

This command queries the low scan channels for the selected step.

Example: Input command "**SAFE:STEP3:DC:CHAN:LOW?**"

Return message "**(@2(2,4))**"

Description: Return message "**(@2(2,4))**" means the low scan channels for STEP 3 are set to BOX 2 channel 2 and 4 LOW output.

[[:SOURce]:SAFEty:STEP<n>:IR[:LEVel] < numeric value >

This command sets the DC voltage level in volts (V) for the selected step.

Range: 50~1000

Example: Input command "**SAFE:STEP4:IR 1000**"

Description: This command sets the DC voltage level for STEP 4 to 1000V.

[[:SOURce]:SAFEty:STEP<n>:IR[:LEVel]?

This command queries the DC voltage level for the selected step.

Example: Input command "**SAFE:STEP4:IR?**"

Return message "**1.000000E+03**"

Description: Return message "**1.000000E+03**" means the DC voltage level for STEP 4 is set to 1000V.

[[:SOURce]:SAFEty:STEP<n>:IR:LIMit:HIGH < numeric value >

This command sets the high resistance limit in ohms (Ω) for the selected step.

Range: 100000~50000000000

Example: Input command "**SAFE:STEP4:IR:LIM:HIGH 5000000000**"

Description: This command sets the high resistance limit for STEP 4 to 50G Ω .

[[:SOURce]:SAFEty:STEP<n>:IR:LIMit:HIGH?

This command queries the high resistance limit for the selected step.

Example: Input command "**SAFE:STEP4:IR:LIM:HIGH?**"

Return message "**5.000000E+10**"

Description: Return message "**5.000000E+10**" means the high resistance limit for STEP 4 is set to 50G Ω .

[[:SOURce]:SAFEty:STEP<n>:IR:LIMit[:LOW] < numeric value >

This command sets the low resistance limit in ohms (Ω) for the selected step.

Range: 100000~50000000000 (low limit value of insulation resistance \leq high limit value)

Example: Input command "**SAFE:STEP4:IR:LIM:100000**"

Description: This command sets the low resistance limit for STEP 4 to 0.1 M Ω .

[[:SOURce]:SAFEty:STEP<n>:IR:LIMit[:LOW]?

This command queries the low resistance limit for the selected step.

Example: Input command "**SAFE:STEP4:IR:LIM?**"

Return message "**1.000000E+05**"

Description: Return message "**1.000000E+05**" means the low resistance limit for STEP 4 is set to 0.1M Ω .

[[:SOURce]:SAFety:STEP<n>:IR:TIME:RAMP < numeric value >

This command sets the ramp time in seconds (s) for the selected step.

Range: 0 or 0.1~999. (0=OFF)

Example: Input command "**SAFE: STEP4: IR: TIME: RAMP 0.5**"

Description: This command sets the ramp time for STEP 4 to 0.5 sec.

[[:SOURce]:SAFety:STEP<n>:IR:TIME:RAMP?

This command queries the ramp time for the selected step.

Example: Input command "**SAFE: STEP4: IR: TIME: RAMP?**"

Return message "**5.000000E-01**"

Description: Return message "**5.000000E-01**" means the ramp time for STEP 4 is set to 0.5 sec.

[[:SOURce]:SAFety:STEP<n>:IR:TIME[:TEST] < numeric value >

This command sets the test time in seconds (s) for the selected step.

Range: 0 or 0.3~999. (0=CONTINUOUS)

Example: Input command "**SAFE:STEP4:IR:TIME 1**"

Description: This command sets the test time for STEP 4 to 1.0sec.

[[:SOURce]:SAFety:STEP<n>:IR:TIME[:TEST]?

This command queries the test time for the selected step.

Example: Input command "**SAFE:STEP4:IR:TIME?**"

Return message "**1.000000E+00**"

Description: Return message "**1.000000E+00**" means the test time for STEP 4 is set to 1 sec.

[[:SOURce]:SAFety:STEP<n>:IR:TIME:FALL < numeric value >

This commands sets the time required for the voltage to fall to 0 in seconds (s) for the selected step.

Range: 0 or 0.1~999.0. (0=OFF)

Example: Input command "**SAFE:STEP4:IR:TIME:FALL 3**"

Description: This command sets the time required for the voltage to fall to 0 for STEP 3 to 3.0sec

[[:SOURce]:SAFety:STEP<n>:IR:TIME:FALL?

This command queries the time required for the voltage to fall to 0 for the selected step.

Example: Input command "**SAFE:STEP4:IR:TIME:FALL?**"

Return message "**3.000000E+00**"

Description: Return message "**3.000000E+00**" means the time required for the voltage to fall to 0 for STEP 3 is set to 3.0sec.

[[:SOURce]:SAFety:STEP<n>:IR:RANGe[:UPPer]

This command selects the range upper than the current measured according to current value

users inputted. The unit is ampere (A).

Range: 0~0.01

Example: Input command "**SAFE:STEP4:IR:RANG 0.0003**"

Description: This command sets IR measured current value of main STEP 4 to 300uA thus the selected IR range upper than the current measured is 3mA.

[[:SOURce]:SAFETy:STEP<n>:IR:RANGe[:UPPer]

This command queries set range.

Example: Input command "**SAFE:STEP4:IR:RANG?**"

Return message "**3.000000E-03**"

Description: Return message "**3.000000E-03**" means set range for main STEP 4 is 3mA.

[[:SOURce]:SAFETy:STEP<n>:IR:RANGe:LOWer

This command selects the range lower than the current measured according to current value

users inputted. The unit is ampere (A).

Range: 0~0.01

Example: Input command "**SAFE:STEP4:IR:RANG:LOW 0.0003**"

Description: This command sets IR measured current value of main STEP 4 to 300uA thus the selected IR range lower than the current measured is 300uA.

[[:SOURce]:SAFETy:STEP<n>:IR:RANGe:LOWer?

This command queries set range.

Example: Input command "**SAFE:STEP4:IR:RANG?**"

Return message "**3.000000E-04**"

Description: Return message "**3.000000E-04**" means set range for main STEP 4 is 300uA.

[[:SOURce]:SAFETy:STEP<n>:IR:RANGe:AUTO

This command sets if IR range be changed to AUTO.

Set to AUTO when parameter is ON or 1.

Set to disable AUTO when parameter is OFF or 0.

Note: It remains the default setting range when AUTO unset and gives OFF parameter. Set 10mA when the default setting is AUTO and gives OFF parameter.

Example: Input command "**SAFE:STEP4:IR:RANG:AUTO ON**"

Description: This command sets IR measured current range for main STEP 4 to AUTO.

[[:SOURce]:SAFETy:STEP<n>:IR:RANGe:AUTO?

This command queries if IR range be changed to AUTO.

Set to AUTO when returns 1.

Set to disable AUTO when returns 0.

Example: Input command "**SAFE:STEP4:IR:AUTO?**"

Return message "**1**"

Description: Return message "**1**" means set range for main STEP 4 is AUTO.

[[:SOURce]:SAFETy:STEP<n>:IR:CHANnel[:HIGH] < channel list >

This command sets the high scan channels for the selected step. The <channel list> format is: (@SN(C1, C2, C3)). SN is the scan box number; C1, C2, and C3 are the channel numbers.

Example: Input command "**SAFE: STEP4: IR:CHAN(@2(1,2))**"

Description: This command sets the high scan channels for STEP 4 to BOX 2 channel 1 and 2 HIGH output.

Example: Input command "**SAFE: STEP4: IR:CHAN(@2(0))**"

Description: This command sets the high channel for STEP 4 to BOX 2 HIGH

output channel to OFF.

[[:SOURce]:SAFEty:STEP<n>:IR:CHANnel[:HIGH]?

This command queries the high scan channel for the selected step.

Example: Input command "**SAFE: STEP4: IR: CHAN?**"

Return message "**(@2(1,2))**"

Description: Return message "**(@2(1,2))**" means the high scan channel for STEP 4 is set to BOX 2 channel 1 and 2 to HIGH output.

[[:SOURce]:SAFEty:STEP<n>:IR:CHANnel:LOW < channel list >

This command sets the low scan channels for the selected step (RTN/LOW).

Example: Input command "**SAFE:STEP4:IR:CHAN:LOW (@2(2,4))**"

Description: This command sets the low scan channel for STEP 4 to channel 2 and 4 LOW output.

Example: Input command "**SAFE:STEP4:IR:CHAN:LOW (@2(0))**"

Description: This command sets the low scan channel for STEP 4 to OFF.

[[:SOURce]:SAFEty:STEP<n>:IR:CHANnel:LOW?

This command queries the low scan channels for the selected step.

Example: Input command "**SAFE:STEP4:IR:CHAN:LOW?**"

Return message "**(@2(2,4))**"

Description: Return message "**(@2(2,4))**" means the low scan channel for STEP 4 is set to BOX 2 channel 2 and 4 LOW output.

[[:SOURce]:SAFEty:STEP<n>:PAuse:MESSAge <string data >

This command sets the message string in the pause mode for the selected step.

Example: Input command "**SAFE: STEP5:PA:MESS CHROMA**"

Description: This command sets the message string for STEP 5 to "CHROMA".

[[:SOURce]:SAFEty:STEP<n>:PAuse:MESSAge?

This command queries the message string in the pause mode for the selected step.

Example: Input command "**SAFE: STEP5: PA: MESS?**"

Return message "**CHROMA**"

Description: Return message "**CHROMA**" means the message string for STEP 5 is set to "CHROMA".

[[:SOURce]:SAFEty:STEP<n>:PAuse:UTSignal < boolean > | ON | OFF

This command sets the status of the UNDER TEST signal.

A parameter of ON or 1 indicates the setting is ON.

A parameter of OFF or 0 indicates the setting is OFF.

Example: Input command "**SAFE:STEP5:PA: UTSI ON**"

Description: This command sets the status of the UNDER TEST signal for STEP 5 to ON.

[[:SOURce]:SAFEty:STEP<n>:PAuse:UTSignal?

This command queries the status of the UNDER TEST signal.

Returns a 1 if the setting is ON.

Returns a 0 if the setting is OFF.

Example: Input command "**SAFE:STEP5:PA:UTSI ON**"

Return message "**1**"

Description: Return message "**1**" means the status of the UNDER TEST signal of STEP 5 is ON.

[[:SOURce]:SAFEty:STEP<n>:PAuse:TIME[:TEST] <numeric_value>

This command sets the time required of PA mode test for the selected step.

Example: Input command "**SAFE:STEP5:PA:TIME 5**"

Description: This command sets the time required for STEP 5 to 5.0sec.

[[:SOURce]:SAFEty:STEP<n>:PAuse:TIME[:TEST]?

This command queries the time required of PA mode test for selected step.

Example: Input command "**SAFE:STEP5:PA:TIME ?**"

Return message "**5.000000E+00**"

Description: Return message "**5.000000E+00**" means the test time required for STEP 5 is set to 5.0sec.

[[:SOURce]:SAFEty:STEP<n>:OSC:CRANge? <MAXimum|MINimum|NOW>

This command queries the maximum, minimum, and current operating ranges of the open/short circuit detection mode for the selected step.

Example: Input command "**SAFE:STEP6:OSC:CRAN? MAX**".

Return message "**3**"

Description: Return message "**3**" means the maximum range that can be set in Step 6 is 3.

[[:SOURce]:SAFEty:STEP<n>:OSC:CURRent<m>:OFFSet <numeric value>

This command sets the Offset value range of the open/short detection mode for the selected step.

Parameter m: The range of open/short detection mode.

Parameter **<numeric value>**: The Offset value of open/short circuit detection mode. The unit is in Farad (F).

Range: Range 1, 2 and 3 are all 0~0.0000009999.

Example: Input command "**SAFE:STEP6:OSC:CURR3:OFFS 0.0000001**".

Description: This command sets the Offset value of range 3 of the open/short circuit detection mode in Step 6 to 10nF.

[[:SOURce]:SAFEty:STEP<n>:OSC:CURRent<m>:OFFSet?

This command queries the Offset value range of the open/short circuit detection mode for the selected step.

Parameter m: The range of open/short detection mode.

Example: Input command "**SAFE:STEP6:OSC:CURR3:OFFS?**".

Return message "**+1.000000E-08**".

Description: Return message "**+1.000000E-08**" means the Offset value under open/short detection mode in Step 6 is 10nF.

[[:SOURce]:SAFEty:STEP<n>:OSC:LIMit[:OPEN] <numeric value >

This command sets the open circuit percentage in percentage (100%) for the selected step

Range: 0.1~1.0

Example: Input command "**SAFE:STEP6:OSC:LIM:OPEN 0.3**"

Description: This command sets the open circuit percentage for STEP 6 to 30%.

[[:SOURce]:SAFEty:STEP<n>:OSC:LIMit[:OPEN]?

This command queries the open circuit percentage for the selected step.

Example: Input command "**SAFE:STEP6:OSC:LIM:OPEN?**"

Return message "**3.000000E-01**"

Description: Return message "**3.000000E-01**" means the open circuit percentage for STEP 6 is set to 30%.

[:SOURce]: SAFETy: STEP<n>: OSC: LIMit: SHORt < numeric value >

This command sets the short circuit percentage in percentage (100%) for the selected step.

Range: 0 or 1~3 (1=100%, 3=300%) (0=OFF)

Example: Input command "**SAFE:STEP6:OSC:LIM:SHOR 3**"

Description: This command sets the short circuit percentage for STEP 6 to 300%.

[:SOURce]: SAFETy: STEP<n>: OSC: LIMit: SHORt?

This command queries the short circuit percentage for the selected step.

Example: Input command "**SAFE:STEP6:OSC:LIM:SHOR?**"

Return message "3.000000E+00"

Description: Return message "3.000000E+00" means the short circuit percentage for STEP 6 is set to 300%.

cha[:SOURce]: SAFETy: STEP<n>: OSC: CHANnel[:HIGH] < channel list >

This command sets the high scan channels for the selected step. The <channel list> format is: (@SN(C1, C2, C3)). SN is the scan box number; C1, C2, and C3 are the channel numbers.

Example: Input command "**SAFE:STEP6:OSC:CHAN(@2(1,2))**"

Description: This command sets the high scan channels for STEP 6 to BOX 2 channel 1 and 2 HIGH output.

Example: Input command "**SAFE:STEP6:OSC:CHAN(@2(0))**"

Description: This command sets the high scan channels for STEP 6 to BOX 2 HIGH output channel to OFF.

[:SOURce]: SAFETy: STEP<n>: OSC: CHANnel[:HIGH]?

This command queries the high scan channels for the selected step.

Example: Input command "**SAFE:STEP6:OSC:CHAN?**"

Return message "@2(1,2)"

Description: Return message "@2(1,2)" means the high scan channel for STEP 6 is set to BOX 2 channel 1 and 2 to HIGH output.

[:SOURce]: SAFETy: STEP<n>: OSC: CHANnel:LOW < channel list >

This command sets the low scan channels for the selected step (RTN/LOW).

Example: Input command "**SAFE:STEP6:OSC:CHAN:LOW (@2(2,4))**"

Description: This command sets the low scan channel for STEP 6 to channel 2 and 4 LOW output.

Example: Input command "**SAFE:STEP6:OSC:CHAN:LOW (@2(0))**"

Description: This command sets the low scan channel for STEP 6 to OFF.

[:SOURce]: SAFETy: STEP<n>: OSC: CHANnel:LOW?

This command queries the low scan channels for the selected step.

Example: Input command "**SAFE:STEP6:OSC:CHAN:LOW?**"

Return message "@2(2,4)"

Description: Return message "@2(2,4)" means the low scan channels for STEP 6 is set to channel 2 and 4 LOW output.

[:SOURce]: SAFETy: STEP<n>: OSC: CSTandard <range>, <numeric value>

This command triggers the analyzer to get the Cs value for the selected step.

Parameter <range>: The range of the open/short circuit detection mode.

Parameter <numeric value>: The Cs value of the open/short circuit detection

mode in Farads (F).

Cs range: Range 1: 0.001~9.999nF

Range 2: 0.01~99.99nF

Range 3: 0.1~500.0nF

Example: Input command "**SAFE:STEP6:OSC:CSTandard 1, 0.000000001**"

Description: This command sets the Cs value in Range 1 under the open/short circuit mode in Step 6 to 1nF.

[:SOURce]:SAFety:STEP<n>:OSC:CSTandard?

This command queries the Cs value for the selected step.

Example: Input command "**SAFE:STEP6:OSC:CSTandard?**"

Return message "**+1.000000E-09**"

Description: Return message "**+1.000000E-09**" means the Cs value for Step 6 is set to 1nF.

[:SOURce]:SAFety:STEP<n>:LC:CURRent:OFFSet[:LC] <numeric value>

This command sets the Offset value for the human body impedance model for the selected step.

Parameter **<numeric value>**: The Offset value of human body simulation circuit Test in Amperes (A). The Offset value must be greater than 0.

6000-05/07 range:

When the High Limit setting range is from 0.1uA to 59.9uA, the High Limit + Offset setting value ≤ 0.000066 .

When the High Limit setting range is from 60uA to 599uA, the High Limit + Offset setting value ≤ 0.00066 .

When the High Limit setting is ≥ 600 uA:

High Limit + Offset setting value of UL544NP ≤ 0.0066 .

High Limit + Offset setting value of UL544P ≤ 0.011 .

High Limit + Offset setting value of UL1563 ≤ 0.011 .

High Limit + Offset setting value of UL2601 ≤ 0.011 .

High Limit + Offset setting value of UL1950 ≤ 0.011 .

6000-04/06/08 range:

When the High Limit setting range is from 0.1uA to 599uA, the High Limit + Offset setting value ≤ 0.00066 .

When the High Limit setting is ≥ 600 uA:

High Limit + Offset setting value of UL544NP ≤ 0.0066 .

High Limit + Offset setting value of UL544P ≤ 0.011 .

High Limit + Offset setting value of UL1563 ≤ 0.011 .

High Limit + Offset setting value of UL2601 ≤ 0.011 .

High Limit + Offset setting value of UL1950 ≤ 0.011 .

High Limit + Offset setting value of 1950-U1 (RMS) ≤ 0.055 .

High Limit + Offset setting value of 1950-U1 (PEAK) ≤ 0.077 .

High Limit + Offset setting value of 2601-U1 ≤ 0.011 .

Note: Only 6000-08 can set DEVICE 1950-U1 and 2601-U1.

Example: Input command "**SAFE:STEP7:LC:CURR:OFFS 0.000001**".

Description: This command sets the Offset value of the human body impedance model in Step 7 to 10uA.

[[:SOURce]:SAFety:STEP<n>:LC:CURR:OFFSet[:LC]?]

This command queries the Offset value of the human body impedance model for the selected step.

Example: Input command "**SAFE:STEP7:LC:CURR:OFFS?**".

Return message "**+1.000000E-05**".

Description: Return message "**+1.000000E-05**" means the Offset value of the human body impedance model in Step 7 is set to 10uA.

[[:SOURce]:SAFety:STEP<n>:LC:CURRent:OFFSet:LAC <numeric value>]

This command sets the Offset value of LAC when testing the human body impedance model for the selected step.

Parameter **<numeric value>**: The Offset value of the human body impedance model in Amperes (A). The LAC Offset value must be greater than 0.

Range:

When the High Limit setting range is from 0.1uA to 599uA, the LAC High Limit + Offset setting value ≤ 0.00066 .

When the High Limit setting is $\geq 600\mu\text{A}$:

LAC High Limit + Offset setting value of UL544NP ≤ 0.0066 .

LAC High Limit + Offset setting value of UL544P ≤ 0.011 .

LAC High Limit + Offset setting value of UL1563 ≤ 0.011 .

LAC High Limit + Offset setting value of UL2601 ≤ 0.011 .

LAC High Limit + Offset setting value of UL1950 ≤ 0.011 .

LAC High Limit + Offset setting value of 1950-U1 (RMS) ≤ 0.055 .

LAC High Limit + Offset setting value of 1950-U1 (PEAK) ≤ 0.077 .

LAC High Limit + Offset setting value of 2601-U1 ≤ 0.011 .

Example: Input command "**SAFE:STEP7:LC:CURR:OFFS:LAC 0.000001**".

Description: This command sets the LAC Offset value of the human body impedance model in Step 7 to 10uA.

[[:SOURce]:SAFety:STEP<n>:LC:CURR:OFFSet:LAC?]

This command queries the LAC Offset value of the human body impedance model for the selected step.

Example: Input command "**SAFE:STEP7:LC:CURR:OFFS:LAC?**".

Return message "**+1.000000E-05**".

Description: Return message "**+1.000000E-05**" means the Offset value of the human body impedance model in Step 7 is set to 10uA.

[[:SOURce]:SAFety:STEP<n>:LC:CURRent:OFFSet:LDC <numeric value>]

This command sets the Offset value of LDC of the human body impedance model for the selected step.

Parameter **<numeric value>**: The Offset value of the human body impedance model in Amperes (A).

Range: LDC High Limit + Offset setting value ≤ 0.0011

Example: Input command "**SAFE:STEP7:LC:CURR:OFFS:LDC 0.000001**".

Description: This command sets the LDC Offset value of the human body impedance model in Step 7 to 10uA.

[[:SOURce]:SAFety:STEP<n>:LC:CURR:OFFSet:LDC?]

This command queries the LDC Offset value of the human body impedance model for the selected step.

Example: Input command **“SAFE:STEP7:LC:CURR:OFFS:LDC?”**.

Return message **“+1.000000E-05”**.

Description: Return message **“+1.000000E-05”** means the Offset value of the human body impedance model in Step 7 is set to 10uA.

[[:SOURce]:SAFety:STEP<n>:LC[:DEVIce] UL1950 | UL1563 | UL544NP | UL544P | UL2601 | 1950-U1 | 2601-U1

This command sets which human body impedance model standards will be used for the selected step.

Example: Input command **“SAFE: STEP 7: LC: DEV UL544NP”**

Description: This command sets the human body impedance model standard in Step 7 to UL544NP.

[[:SOURce]:SAFety:STEP<n>:LC[:DEVIce]?

This command queries which human body impedance model standards is being used for the selected step.

Example: Input command **“SAFE: STEP7: LC: DEV?”**

Return message **“UL544NP”**

Description: Return message **“UL544NP”** means the human body impedance model standard being used in STEP 7 is UL544NP.

[[:SOURce]:SAFety:STEP<n>:LC:DISPlay RMS|PEAK

This command sets the display mode for the LC leakage current for the selected step.

Example: Input command **“SAFE:STEP7:LC:DISPlay RMS”**

Description: Sets the display mode for the LC leakage current in STEP 7 to RMS.

[[:SOURce]:SAFety:STEP<n>:LC:DISPlay?

This command queries the display mode for the LC leakage current for the selected step.

Example: Input command **“SAFE:STEP7:LC:DISPlay RMS”**

Description: Return message **“RMS”** means the display mode for the LC leakage current in STEP 7 is set to RMS.

[[:SOURce]:SAFety:STEP<n>:LC:LAC[:HIGH] <Range 0 ~ high limit> (0=OFF)

This command sets the high limit of the LAC leakage current in Amperes (A) for the selected step.

Range: LAC HIGH LIMIT value ≤ LC HIGH LIMIT value (0=OFF)

DEVICE is UL544NP : 0.0000001~0.006

DEVICE is UL544P : 0.0000001~0.01

DEVICE is UL1563 : 0.0000001~0.01

DEVICE is UL2601-1 : 0.0000001~0.01

DEVICE is UL1950 : 0.0000001~0.01

DEVICE is 1950-U1(RMS) : 0.0000001~0.05

DEVICE is 1950-U1(PEAK) : 0.0000001~0.07

DEVICE is 2601-U1 : 0.0000001~0.01

Example: Input command **“SAFE:STEP7:LC:LAC:HIGH 0.0001”**

Description: This command sets the high limit of the LAC leakage current for STEP 7 to 0.1mA.

[[:SOURce]:SAFety:STEP<n>:LC:LAC?

This command queries the LAC leakage current value for the selected step.

Example: Input command **“SAFE:STEP7:LC:LAC?”**

Description: Return message "1.000000E-04" means the high limit of the LAC leakage current for STEP 7 is set to 0.1mA.

[[:SOURce]:SAFETy:STEP<n>:LC:LDC[:HIGH] <Range 0 ~ high limit>0 (0=OFF)

This command sets the high limit of the LDC leakage current in Amperes (A) for the selected step.

Range: 0 or 0.000001~HIGH LIMIT value. If the High Limit value is larger than 1mA then the maximum value that can be set is 0.001 (0=OFF)

Example: Input command "**SAFE:STEP7:LC:LDC:HIGH 0.001**"

Description: This command sets the high limit of the LDC leakage current for step 7 to 1mA.

[[:SOURce]:SAFETy:STEP<n>:LC:LDC?

This command queries the LDC leakage current value for the selected step.

Example: Input command "**SAFE:STEP7:LC:LDC?**"

Description: Return message "1.000000E-03" means the high limit of the LDC leakage current for STEP 7 is set to 1mA.

[[:SOURce]:SAFETy:STEP<n>:LC:LINE *NORmal* | *REVerse* | *SFNormal* | *SFReverse*

This command selects which power circuit status simulation mode to use for the selected step.

Example: Input command "**SAFE:STEP7:LC:LINE REV**"

Description: This command sets the power circuit status simulation mode for step 7 to Reverse.

[[:SOURce]:SAFETy:STEP<n>:LC:LINE?

This command queries which power circuit status simulation mode is active for the selected step.

Example: Input command "**SAFE:STEP7:LC:LINE?**"

Return message "REVERSE"

Description: Return message "REVERSE" means the power circuit status simulation mode for STEP 7 is Reverse.

[[:SOURce]:SAFETy:STEP<n>:LC:METER *L* | *P, P* | *G*

This command sets the measurement point of leakage current for the selected step. (The test mode in P-G isn't allowed.)

Example: Input command "**SAFE:STEP7:LC:METER L,P**"

Description: This command sets the measurement point of leakage current of STEP 7 to L, P.

[[:SOURce]:SAFETy:STEP<n>:LC:METER?

This command queries the measurement point of leakage current for the selected step.

Example: Input command "**SAFE:STEP7:LC:METE?**"

Return message "L, P"

Description: Return message "L, P" means the measurement point of leakage current in STEP 7 is L-P.

[[:SOURce]:SAFETy:STEP<n>:LC:GSWItch < *boolean* > | *ON* | *OFF*

This command sets the ground switch status for the selected step.

Example: Input command "**SAFE:STEP7:LC:GSWI ON**"

Description: This command sets the ground switch status for STEP 7 to ON.

[[:SOURce]:SAFety:STEP<n>:LC:GSWitch?

This command queries the ground switch status for the selected step.

Example: Input command "**SAFE:STEP7:LC:GSWI?**"

Return message "1".

Description: Return message "1" means the ground switch status for STEP 7 is ON.

[[:SOURce]:SAFety:STEP<n>:LC:LIMit[:HIGH] < numeric value >

This command sets the leakage current high limit value for the selected step.

Setting range

DEVICE is UL544NP	: 0.0000001 ~ 0.006
DEVICE is UL544P	: 0.0000001 ~ 0.01
DEVICE is UL1563	: 0.0000001 ~ 0.01
DEVICE is UL2601-1	: 0.0000001 ~ 0.01
DEVICE is UL1950	: 0.0000001 ~ 0.01
DEVICE is 1950-U1(RMS)	: 0.0000001 ~ 0.05
DEVICE is 1950-U1(PEAK)	: 0.0000001 ~ 0.07
DEVICE is 2601-U1	: 0.0000001 ~ 0.01

Example: Input command "**SAFE:STEP7:LC:LIM 0.006**"

Description: This command sets the leakage current high limit value for STEP 7 to 6mA.

[[:SOURce]:SAFety:STEP<n>:LC:LIMit[:HIGH]?

This command queries the leakage current high limit value for the selected step.

Example: Input command "**SAFE:STEP7:LC: LIM?**"

Return message "6.000000E-03".

Description: Return message "6.000000E-03" means the leakage current high limit value for STEP 7 is set to 6mA.

[[:SOURce]:SAFety:STEP<n>:LC:LIMit:LOW < numeric value >

This command sets the leakage current low limit value in amperes (A).

Range: LOW LIMIT value ≤ HIGH LIMIT value. (0=OFF).

DEVICE is UL544NP	: 0,0.0000001~0.006
DEVICE is UL544P	: 0,0.0000001~0.01
DEVICE is UL1563	: 0,0.0000001~0.01
DEVICE is UL2601-1	: 0,0.0000001~0.01
DEVICE is UL1950	: 0,0.0000001~0.01
DEVICE is 1950-U1(RMS)	: 0,0.0000001~0.05
DEVICE is 1950-U1(PEAK)	: 0,0.0000001~0.07
DEVICE is 2601-U1	: 0,0.0000001~0.01

Example: Input command "**SAFE:STEP7:LC:LIM:LOW 0.0005**"

Description: This command sets the leakage current low limit value for STEP 7 to 0.5mA.

[[:SOURce]:SAFety:STEP<n>:LC:LIMit:LOW?

This command queries the leakage current low limit value for the selected step.

Example: Input command "**SAFE:STEP7:LC:LIM?**"

Return message "5.000000E-04"

Description: Return message "5.000000E-04" means the leakage current low limit value for STEP 7 is set to 0.5mA.

[[:SOURce]:SAFety:STEP<n>:LC:TIME[:TEST] < numeric value >

This command sets the test duration time in seconds (s) for the selected step.

Range: 0 or 0.3~999.0, 0 is for setting CONTINUE

Example: Input command **"SAFE:STEP7:LC:TIME 5"**

Description: This command sets the test duration time for STEP 7 to 5.0sec.

[[:SOURce]:SAFety:STEP<n>:LC:TIME[:TEST]?

This command queries the test duration for the selected step.

Example: Input command **"SAFE:STEP7:LC:TIME?"**

Return message **"5.000000E+00"**

Description: Return message **"5.000000E+00"** means the test duration time for STEP 7 is set to 5.0sec.

[[:SOURce]:SAFety:STEP<n>:LC:TIME:DWEL < numeric value >

This command sets the dwell time in seconds (s) for the selected step.

Range: 0 or 0.1~999.0. (0=OFF).

Example: Input command **"SAFE:STEP7:LC:TIME:DWEL 2.0"**

Description: This command sets the dwell time for STEP 7 to 2.0sec.

[[:SOURce]:SAFety:STEP<n>:LC:TIME:DWEL?

This command queries the dwell time for the selected step.

Example: Input command **"SAFE:STEP 7:LC:TIME:DWEL?"**

Return message **"2.000000E+00"**

Description: Return message **"2.000000E+00"** means the dwell time setting for STEP 7 is set to 2.0sec.

[[:SOURce]:SAFety:STEP<n>:LC:POWer:MODE VOLTage | CURRent | VA | SIMUlation | SOURce

This command sets the power measurement mode for the selected step.

Example: Input command **"SAFE:STEP7:LC:POW:MODE VOLTage"**

Description: This command sets the power measurement mode for STEP 7 to VOLTAGE.

[[:SOURce]:SAFety:STEP<n>:LC:POWer:MODE?

This command queries the power measurement mode for the selected step.

Example: Input command **"SAFE:STEP 7:LC:POW: MODE?"**

Return message **"VOLTAGE"**

Description: Return message **"VOLTAGE"** means the power measurement mode for STEP 7 is set to VOLTAGE.

[[:SOURce]:SAFety:STEP<n>:LC:POWer:VOLTage[:LIMit][:HIGH] < numeric value >

This command sets the power voltage measurement high limit in volts (V) for the selected step.

Range: 0 or 0.1~300.0. (0=OFF).

Example: Input command **"SAFE:STEP7:LC:POW:VOLT 220"**

Description: This command sets the power voltage measurement high limit value for STEP 7 to 220V.

[[:SOURce]:SAFety:STEP<n>:LC:POWer:VOLTage[:LIMit][:HIGH]?

This command queries the power voltage measurement high limit value for the selected step.

Example: Input command **"SAFE:STEP7:LC:POW:VOLT?"**

Return message **"2.200000E+02"**

Description: Return message **"2.200000E+02"** means the power voltage measurement high limit value for STEP 7 is set to 220V.

[[:SOURce]:SAFETy:STEP<n>:LC:POWer:VOLTage[:LIMit]:LOW < numeric value >

This command sets the power voltage measurement low limit value in volts (V).
Range: 0 or 0.1~300.0. (0=OFF) (Low limit value of voltage measurement \leq high limit value)

Example: Input command "**SAFE:STEP7:LC:POW:VOLT:LOW 110**"

Description: This command sets the power voltage measurement low limit value for STEP 7 to 110V.

[[:SOURce]:SAFETy:STEP<n>:LC:POWer:VOLTage[:LIMit]:LOW?

This command queries the power voltage measurement low limit value for the selected step.

Example: Input command "**SAFE:STEP7:LC:POW:VOLT:LOW?**"

Return message "**1.100000E+02**"

Description: Return message "**1.100000E+02**" means the power voltage measurement low limit value for STEP 7 is set to 110V.

[[:SOURce]:SAFETy:STEP<n>:LC:POWer:CURRent[:LIMit][:HIGH] < numeric value >

This command sets the power current measurement high limit value in amperes (A) for the selected step.

Range: 0 or 0.001~20. (0=OFF).

Example: Input command "**SAFE:STEP7:LC:POW:CORR 5**"

Description: This command sets the power current measurement high limit value for STEP 7 to 5A.

[[:SOURce]:SAFETy:STEP<n>:LC:POWer:CURRent[:LIMit][:HIGH]?

This command queries the power current measurement high limit value for the selected step.

Example: Input command "**SAFE:STEP7:LC:POW:CURR?**"

Return message "**5.000000E+00**"

Description: Return message "**5.000000E+00**" means the power current measurement high limit value for STEP 7 is set to 5A.

[[:SOURce]:SAFETy:STEP<n>:LC:POWer:CURRent[:LIMit]:LOW < numeric value >

This command sets the power current measurement low limit value in amperes (A) for the selected step.

Range: 0 or 0.001~20. (0=OFF). (Low limit value of current measurement \leq high limit value).

Example: Input command "**SAFE:STEP7:LC:POW:CORR:LOW 0.5**"

Description: This command sets the power current measurement low limit value for STEP 7 to 0.5A.

[[:SOURce]:SAFETy:STEP<n>:LC:POWer:CURRent[:LIMit]:LOW?

This command queries the power current measurement low limit value for the selected step.

Example: Input command "**SAFE:STEP7:LC:POW:CURR:LOW?**"

Return message "**5.000000E-01**"

Description: Return message "**5.000000E-01**" means the power current measurement low limit value for STEP 7 is set to 0.5A.

[[:SOURce]:SAFETy:STEP<n>:LC:POWer:VA[:LIMit][:HIGH] < numeric value >

This command sets the power measurement high limit value in volt-amperes (VA) for the selected step.

Range: 0 or 0.1~4400. (0=OFF).

Example: Input command "**SAFE:STEP7:LC:POW:VA 110**"

Description: This command sets the power measurement high limit value for STEP 7 to 110VA.

[[:SOURce]:SAFETy:STEP<n>:LC:POWer:VA[:LIMit][:HIGH]?

This command queries the power measurement high limit value for the selected step.

Example: Input command "**SAFE:STEP7:LC:POW:VA?**"

Return message "**1.100000E+02**"

Description: Return message "**1.100000E+02**" means the power measurement high limit value for STEP 7 is set to 110VA.

[[:SOURce]:SAFETy:STEP<n>:LC:POWer:VA[:LIMit]:LOW < numeric value >

This command sets the power measurement low limit value step in volt-amperes (VA) for the selected.

Range: 0 or 0.1~4400. (0=OFF). (Low limit value of power measurement \leq high limit value)

Example: Input command "**SAFE:STEP7:LC:POW:VA:LOW 90**"

Description: This command sets the power measurement low limit value for STEP 7 to 90VA.

[[:SOURce]:SAFETy:STEP<n>:LC:POWer:VA[:LIMit]:LOW?

This command queries the power measurement low limit value for the selected step.

Example: Input command "**SAFE:STEP7:LC:POW:LOW:VA?**"

Return message "**9.000000E+01**"

Description: Return message "**9.000000E+01**" means the power measurement low limit value for STEP 7 is set to 90VA.

[[:SOURce]:SAFETy:STEP<n>:LC:POWer:SIMUlation:TVOLtage < numeric value >

This command sets the target value of the power voltage simulation in volts (V) for the selected step.

Range: 80~300

Example: Input command "**SAFE:STEP 7:LC:POW:SIMU:TVOL 127**"

Description: This command sets the target value of the power voltage simulation for STEP 7 to 127V.

[[:SOURce]:SAFETy:STEP<n>:LC:POWer:SIMUlation:TVOLtage?

This command queries the target value of the power voltage simulation for the selected step.

Example: Input command "**SAFE:STEP7:LC:POW:SIMU:TVOL?**"

Return message "**1.270000E+02**"

Description: Return message "**1.270000E+02**" means the target value of the power voltage simulation for STEP 7 is set to 127V.

[[:SOURce]:SAFETy:STEP<n>:LC:POWer:SOURce:TVOLtage < numeric value >

This command sets the source power voltage value in volts (V) for the selected step.

Range: 80~300

Example: Input command **“SAFE:STEP7:LC:POW:SOUR:TVOL 90”**

Description: This command sets the source power voltage value for STEP 7 to 90V.

[:SOURce]:SAFETy:STEP<n>:LC:POWer:SOURce:TVOLtage?

This command queries the source power voltage value for the selected step.

Example: Input command **“SAFE:STEP7:LC:POW:SOUR:TVOL?”**

Return message **“9.000000E+01”**

Description: Return message **“9.000000E+01”** means the source power voltage value for STEP 7 is set to 90V.

[:SOURce]:SAFETy:STEP<n>:LC:POWer:SOURce: TFRrequency< numeric value >

This command sets the source power frequency value in hertz (Hz) for the selected step.

Range: 50~60

Example: Input command **“SAFE:STEP7:LC:POW:SOUR:TFR 60”**

Description: This command sets the source power frequency value for STEP 7 to 60Hz.

[:SOURce]:SAFETy:STEP<n>:LC:POWer:SOURce: TFRrequency?

This command queries the source power frequency value for the selected step.

Example: Input command **“SAFE:STEP7:LC:POW:SOUR:TFR?”**

Return message **“6.000000E+01”**

Description: Return message **“6.000000E+01”** means the source power frequency value for STEP 7 is set to 60Hz.

[:SOURce]:SAFETy:STEP<n>:LC:UPM < boolean > | ON | OFF

This command sets the UPM status of the selected step.

Example: Input command **“SAFE:STEP7:LC:UPM ON”**

Description: The command sets the UPM status for STEP 7 to ON.

[:SOURce]:SAFETy:STEP<n>:LC:UPM?

This command queries the UPM status of the selected step.

Example: Input command **“SAFE:STEP7:LC:UPM?”**

Return message **“1”**

Description: Return message **“1”** means the UPM status for STEP 7 is set to ON.

[:SOURce]:SAFETy:STEP<n>:LC:CHANnel[:LOW] < channel list >

This command sets selected step which setting of return terminal.

Example: Input command **“SAFE:STEP7:LC:CHAN (@1(3))”**

Description: This command sets output channel status of scanning test of the main unit STEP 7 to BOX 1 channel 3 LOW output.

[:SOURce]:SAFETy:STEP<n>:LC:CHANnel[:LOW]?

This command queries selected step which setting of return terminal.

Example: Input command **“SAFE:STEP7:LC:CHAN?”**

Return message **“(@1(3))”**

Description: Return message **“(@1(3))”** means output channel status of scanning test STEP 7 is BOX 1 channel 3 LOW output.

[:SOURce]:SAFETy:PRESet:TIME:PASS < numeric value >

This command sets the length of time the buzzer sounds in seconds (s) when a test passes.

Range: 0.2~99.9.

Example: Input command **“SAFE:PRESet:TIME:PASS 3”**

Description: This command sets the length of time the buzzer sounds to 3 seconds when the test passes.

[[:SOURce]:SAFETy:PRESet:TIME:PASS?

This command queries the length of time the buzzer sounds when a test passes.

Example: Input command "**SAFE:PRES:TIME:PASS?**"

Return message "**3.000000E+00**"

Description: Return message "**3.000000E+00**" means the buzzer sound time is 3 seconds when the test passes.

[[:SOURce]:SAFETy:PRESet:TIME:STEP < numeric value > | KEY

This command sets the interval time between steps, or from the next start command to execute the next step, in seconds (s).

Range: KEY or 0.1~99.9.

Example: Input command "**SAFE:PRES:TIME:STEP 0.5**"

Description: This command sets the interval time between steps to 0.5 seconds.

[[:SOURce]:SAFETy:PRESet:TIME:STEP?

This command queries the interval time between steps.

Example: Input command "**SAFE:PRES:TIME:PASS?**"

Return message "**5.000000E-01**"

Description: Return message "**5.000000E-01**" means the interval time between steps is set to 0.5 second.

[[:SOURce]:SAFETy:PRESet:TIME:ASStart < numeric value >

This command sets the Start Wait delay time in seconds (s).

Range: 0 or 0.1~99.9. (0=OFF).

Example: Input command "**SAFE:PRES:TIME:AST 1**"

Description: This command sets the Start Wait delay time to 1 second.

[[:SOURce]:SAFETy:PRESet:TIME:ASStart?

This command queries the Start Wait delay time.

Example: Input command "**SAFE:PRES:TIME:AST?**"

Return message "**1.000000E+00**"

Description: Return message "**1.000000E+00**" means the Start Wait delay time is set to 0.5 seconds.

[[:SOURce]:SAFETy:PRESet:GB:FREQuency < numeric value >

This command sets the output current frequency during ground bond testing in Hertz (Hz).

Range: 50/60

Example: Input command "**SAFE:PRES:GB:FREQ 50**"

Description: This command sets the output current frequency to 50Hz during ground bond testing.

[[:SOURce]:SAFETy:PRESet:GB:FREQuency?

This command queries the output current frequency during ground bond testing.

Example: Input command "**SAFE:PRES:GB:FREQ?**"

Return message "**5.000000E+01**"

Description: Return message "**5.000000E+01**" means the output current frequency is set to 50Hz during ground bond testing.

[[:SOURce]:SAFETy:PRESet:GB:VOLTage < numeric value >

This command sets the open circuit voltage during ground bond testing, in Volts

(V).

Range: 6~9

Example: Input command **“SAFE:PRES:GB:VOLT 9”**

Description: This command sets the open circuit voltage to 9V during ground bond testing.

[[:SOURce]:SAFETy:PRESet:GB:VOLTage?

This command queries the open circuit voltage during ground bond testing.

Example: Input command **“SAFE:PRES:GB:VOLT?”**

Return message **“9.000000E+00”**

Description: Return message **“9.000000E+00”** means the open circuit voltage is set to 9V during ground bond testing.

[[:SOURce]:SAFETy:PRESet:AC:FREQuency < numeric value >

This command sets the output voltage frequency for the AC withstand voltage test in hertz (Hz).

Range: 50~600

Example: Input command **“SAFE:PRES:AC:FREQ 60”**

Description: This command sets the output voltage frequency to 60Hz for the AC withstand voltage test.

[[:SOURce]:SAFETy:PRESet:AC:FREQuency?

This command queries the output voltage frequency for the AC withstand Voltage test.

Example: Input command **“SAFE:PRES:AC:FREQ?”**

Return message **“6.000000E+01”**

Description: Return message **“6.000000E+01”** means the output voltage frequency is set to 60Hz for the AC withstand voltage test.

[[:SOURce]:SAFETy:PRESet:WRANge[:AUTO] < boolean > | ON | OFF

This command sets the withstand voltage auto range function to ON or OFF.

Example: Input command **“SAFE:PRES:WRAN ON”**

Description: This command sets the withstand voltage auto range function to ON.

[[:SOURce]:SAFETy:PRESet:WRANge[:AUTO]?

This command queries if the withstand voltage auto range function is ON or OFF.

Example: Input command **“SAFE:PRES:WRAN?”**

Return message **“1”**

Description: Return message **“1”** means the withstand voltage auto range function is ON.

[[:SOURce]:SAFETy:PRESet:AGC[:SOFTware] < boolean > | ON | OFF

This command sets the software AGC to ON or OFF.

Example: Input command **“SAFE:PRES:AGC ON”**

Description: This command sets the software AGC to ON.

[[:SOURce]:SAFETy:PRESet:AGC[:SOFTware]?

This command queries if the software AGC is ON or OFF.

Example: Input command **“SAFE:PRES:AGC?”**

Return message **“1”**

Description: Return message **“1”** means the software AGC is ON.

[[:SOURce]:SAFETy:PRESet:NUMber:PART < string data >

This command sets the part number of the product.

Example: Input command **SAFE:PRES:NUM:PART "19032"**

Description: This command sets the part number of the product to 19032.

[[:SOURCE]:SAFETY:PRESet:NUMber:PART?

This command queries the part number of the product.

Example: Input command **"SAFE:PRES:NUM:PART?"**

Return message **"19032"**

Description: Return message **"19032"** means the part number of the product is 19032.

[[:SOURCE]:SAFETY:PRESet:NUMber:LOT < string data >

This command sets the lot number of the product.

Example: Input command **"SAFE:PRES:NUM:LOT 0032"**

Description: This command sets the lot number of the product to 0032.

[[:SOURCE]:SAFETY:PRESet:NUMber:LOT?

This command queries the lot number of the product.

Example: Input command **"SAFE:PRES:NUM:LOT?"**

Return message **"0032"**

Description: Return message **"0032"** means the lot number of the product is 0032.

[[:SOURCE]:SAFETY:PRESet:NUMber:SERIal < string data >

This command sets the serial number format of the product. A changeable character is denoted by **"**"**.

Example: Input command **"SAFE:PRES:NUM:SERI AAP190320***"**

Description: This command sets the serial number format of the product to **AAP190320*****.

[[:SOURCE]:SAFETY:PRESet:NUMber:SERIal?

This command queries the serial number format of the product.

Example: Input command **"SAFE:PRES:NUM:SERI?"**

Return message **"AAP190320***"**

Description: Return message **"AAP190320***"** means the serial number format of the product is **AAP190320*****.

[[:SOURCE]:SAFETY:PRESet:IEC < boolean > | ON | OFF

This command sets the IEC-601 function to ON or OFF.

Example: Input command **"SAFE:PRES:IEC ON"**

Description: This command sets the IEC-601 function to ON.

[[:SOURCE]:SAFETY:PRESet:IEC?

This command queries if the IEC-601 is ON or OFF.

Example: Input command **"SAFE:PRES:IEC?"**

Return message **"1"**

Description: Return message **"1"** means the IEC-601 is set to ON.

[[:SOURCE]:SAFETY:PRESet:RJUDgmnet < boolean > | ON | OFF

This command sets Ramp Judg. to ON or OFF.

Example: Input command **"SAFE:PRES:RJUD ON"**

Description: This command sets Ramp Judg. to ON.

[[:SOURCE]:SAFETY:PRESet:RJUDgment?

This command queries if Ramp Judg. is ON or OFF.

Example: Input command **"SAFE:PRES:RJUD?"**

Return message "1"

Description: Return message "1" means Ramp Judg. is set to ON.

[[:SOURce]:SAFEty:PRESet:SCREen < *boolean* > | ON | OFF

This command enables or disables the Screen function.

Example: Input command "**SAFE:PRESet:SCRE OFF**".

Description: This command turns OFF the analyzer screen.

TRIGger:SOURce:EXTErnal:STATe < *boolean* > | ON | OFF

This command enables or disables the START KEY when the unit is operating under remote control.

The START KEY will be enabled when the unit is operating under remote control when the parameter is set to ON (1).

The START KEY will be disabled when the unit is operating under remote control when the parameter is set to OFF (0).

Example: Input command "**TRIG:SOUR:EXT:STAT 0**"

Description: This command disables the START KEY when the unit is operating under remote control.

TRIGger:SOURce:EXTErnal:STATe?

This command queries the enabled/disabled status of the START KEY when the unit is operating under remote control.

Example: Input command "**TRIG:SOUR:EXT:STAT?**"

Return message "0"

Description: Return message "0" means the START KEY will be disabled when the unit is operating under remote control.

5.4.3 Start Test by Serial No.

This analyzer will start a test when the remote interface receives a string that matches a DUT Serial Number. For example: if the DUT Serial No. has been set to "AA*****" (* refers to a variable character) and "AA00001" or "AA00300" is received from the remote interface, the test will be started.

5.5 Error Messages

The Error Log contains messages that apply to the operation of the instrument with an RS-232 or GPIB (IEEE-488) Interface installed. Refer to the list of these error messages below. When there is an error in the queue, the ERROR LED in the lower right-hand corner of the display will be illuminated. To access the ERROR LOG, press the [MENU] function key at the top left hand corner of the keypad and press the numeric key [7].

Error messages for the instrument are saved in the queue and are accessed by the FIFO method. The first error message is the first saved. When the messages in the queue reach 31, the message in the last position will display “-350, Queue Overflow”.

Reading a message from the Error Log deletes the error message from the queue.

Error #	Label	Message Description
+ 0	No error	No error messages in the queue
-102	Syntax error	The command contains an invalid character
-103	Invalid separator	The command contains an invalid separator
-108	Parameter not allowed	Parameter is invalid and cannot be measured
-109	Missing parameter	Test cannot be performed without missing parameter
-112	Program mnemonic too long	The header contains more than 12 characters
-113	Undefined header	Header is unrecognizable
-114	Header suffix out of range	Value of numeric suffix is out of range
-120	Numeric data error	Numeric parameter is invalid
-140	Character data error	Input character is invalid
-151	Invalid string data	Incomplete string of data (i.e. missing double “ ” marks)
-158	String data not allowed	Invalid string of data
-170	Expression error	Incomplete parameter data (i.e. missing right parenthesis)
-200	Execution error	Invalid execute command
-203	Command protected	Invalid command; device does not receive this command
-221	Settings conflict	Device is busy and cannot receive command
-222	Data out of range	Parameter value is out of range
-223	Too much data	Received string is too long, device can't execute
-291	Out of memory	Main memory is full, data cannot be stored
-292	Referenced name does not exist	Referenced name not found in main memory
-293	Referenced name already exists	Memory already contains a file labeled 'referenced name'
-350	Queue overflow	More than 30 messages in error queue
-361	Parity error	Program message contains parity error
-363	Time out error	End character not received in time, device timed out
-365	Input buffer over run	Input buffer is out of range
-400	Queue error	Output buffer is out of range
-410	Query Interrupted	No read command following a query command
-420	Query Unterminated	No data in queue and device requested to read queue

5.6 Basic Examples

5.6.1 GPIB

■ Operation by GPIB Using Basic

```

REM-----
REM      run the ULI file before this program.
REM      This program is that getting results through GPIB from the device.
REM      GPIB address is 3
REM-----

CLS
PRINT "Program is running..."
OPEN "GPIB0" FOR OUTPUT AS #1           \open #1 for output (write)
OPEN "GPIB0" FOR INPUT AS #2           \open #2 for input (read)

PRINT #1, "ABORT"                       \initializing message.
PRINT #1, "GPIBEOS IN LF"               \set the end code

PRINT #1, "OUTPUT 3;:SOURce:SAFety:STOP"      send STOP command to device 3
PRINT #1, "OUTPUT 3;:SOURce:SAFety:SNUMBer?"
PRINT #1, "ENTER 3"
INPUT #2, STEPNUM%

PRINT "DEL STEPS"
IF STEPNUM% > 0 THEN
    FOR I% = STEPNUM% TO 1 STEP - 1
        PRINT #1, "OUTPUT 3;:SOURce:SAFety:STEP", I%, ":DELeTe"
    NEXT I%
END IF                                     \clear all steps

PRINT "SET STEPS"
PRINT #1, "OUTPUT 3;:SOURce:SAFety:STEP 1:DC 1000"
PRINT #1, "OUTPUT 3;:SOURce:SAFety:STEP 1:DC:LIMit 0.004"
PRINT #1, "OUTPUT 3;:SOURce:SAFety:STEP 1:DC:TIME 2"

PRINT #1, "OUTPUT 3;:SOURce:SAFety:STEP 2:AC 1000"
PRINT #1, "OUTPUT 3;:SOURce:SAFety:STEP 2:AC:LIMit 0.02"
PRINT #1, "OUTPUT 3;:SOURce:SAFety:STEP 2:AC:TIME:TEST 3"

PRINT #1, "OUTPUT 3;:SOURce:SAFety:STOP"
PRINT #1, "OUTPUT 3;:SOURce:SAFety:StArt"      \start test

STATUS$ = "RUNNING"
WHILE STATUS$ <> "STOPPED"
    PRINT #1, "OUTPUT 3;:SAFety:StAtus?"
    PRINT #1, "ENTER 3"
    INPUT #2, STATUS$
    PRINT STATUS$

    IF STATUS$ = "STOPPED" THEN
        PRINT #1, "OUTPUT 3;:SOURce:SAFety:STOP"
        PRINT #1, "OUTPUT 3;:SAFety:RESult:ALL:OMET?"
        PRINT #1, "ENTER 3"

        FOR J% = 1 TO STEPNUM%
            INPUT #2, RESULT$
        
```

```

        PRINT "STEP", J%, ":", RESULT$
    NEXT J%

    PRINT
    PRINT #1, "OUTPUT 3;:SAFETy:RESult:ALL:MMET?"
    PRINT #1, "ENTER 3"

    FOR J% = 1 TO STEPNUM%
        INPUT #2, RESULT$
        PRINT "STEP", J%, ":", RESULT$
    NEXT J%
    END IF
WEND

PRINT #1, "OUTPUT 3;:SOURce:SAFETy:STOP"
CLOSE : SYSTEM
END

```

■ Save and Recall by GPIB Using Basic

```

REM -----
REM   Program compiled using Microsoft version 1.1(MS-DOS 6.22)
REM   run the ULI file before this program
REM   Device GPIB address is 3
REM -----

OPEN "GPIB0" FOR OUTPUT AS #1      `open #1 for output (write)
OPEN "GPIB0" FOR INPUT AS #2      `open #2 for input (read)
PRINT #1, "ABORT"                  `initializing complete
PRINT #1, "GPIBEOS IN LF"          `set the end code

PRINT #1, "OUTPUT 3;SOURce:SAFETy:STEP1:GB:LEVel 25"
PRINT #1, "OUTPUT 3;SOURce:SAFETy:STEP1:GB:LIMit:HIGH 0.02"

PRINT #1, "OUTPUT 3;SOURce:SAFETy:STEP2:AC:LEVel 500"
PRINT #1, "OUTPUT 3;SOURce:SAFETy:STEP2:AC:LIMit:HIGH 0.04"

PRINT #1, "OUTPUT 3;*SAV 1"         `Work memory were Stored in memory 1
PRINT #1, "OUTPUT 3;MEMory:DEFine AAA,1" `Define the name of memory 1 is AAA

PRINT #1, "OUTPUT 3;SOURce:SAFETy:STEP3:DC:LEVel 700"
PRINT #1, "OUTPUT 3;SOURce:SAFETy:STEP3:DC:LIMit:HIGH 0.01"

PRINT #1, "OUTPUT 3;SOURce:SAFETy:STEP4:IR:LEVel 800"
PRINT #1, "OUTPUT 3;SOURce:SAFETy:STEP4:IR:LIMit:HIGH 5000000"

PRINT #1, "OUTPUT 3;*SAV 3"         `Work memory were Stored in memory 3
PRINT #1, "OUTPUT 3;MEMory:DEFine BBB,3" `Define the name of memory 3 is BBB

PRINT #1, "OUTPUT 3;*RCL 1"        `Recall the memory 1

CLOSE : SYSTEM
END

```

■ Using Status Reporting by GPIB Using Basic

```
REM-----
REM   run the ULI file before this program.
REM   This program is that getting results through GPIB from the device.
REM   Device GPIB address is 3
REM-----

CLS
PRINT "Program is running..."
OPEN "GPIB0" FOR OUTPUT AS #1           'set the talker
OPEN "GPIB 0" FOR INPUT AS #2         'set the listener

REM define the SRQ-handling routine
ON PEN GOSUB MySRQRoutine

REM Enable the on SRQ functionality
PEN ON

PRINT #1, "ABORT"                      'initializing complete
PRINT #1, "GPIBEOS IN LF"              'set the end code
PRINT "waiting for SRQ from device"
PRINT #1, "OUTPUT 3;:SOURCE:SAFETY:STOP" 'STOP the Device

PRINT #1, "OUTPUT 3;*SRE 32"           'set status enable register
PRINT #1, "OUTPUT 3;*ESE 60"          'set standard enable register

PRINT #1, "OUTPUT 3;:sdf"              'send undefined command
FOR I% = 1 TO 10000
    PRINT " wait for SRQ ", I%
NEXT I%
PRINT "Program is stopped!"

GOTO END1

MySRQRoutine:                          'SRQ interrupt
PEN OFF
PRINT "Running the SRQ"
PRINT #1, "OUTPUT 3;*ESR?"
PRINT #1, "ENTER 3"
INPUT #2, C%                            'get the questionable state

IF C% = 32 THEN
    PRINT "All Pass"
ELSE
    PRINT " Fail "
END IF                                    'End of SRQ interrupt

END1:
CLOSE : SYSTEM
END
```

5.6.2 RS-232 Operation Using Basic

```

REM-----
REM   Program compiled using Microsoft version 1.1(MS-DOS 6.22)
REM   RS-232 example program
REM-----

OPEN "COM1:9600,N,8,1,LF" FOR RANDOM AS #1      'open serial port 1 as device
1
PRINT #1, "SOURce:SAFety:STOP"                'send "STOP" command to
device

PRINT #1, "SOURce:SAFety:SNUMBer?"
INPUT #1, STEPNUM%

IF STEPNUM% > 0 THEN
  FOR I% = STEPNUM% TO 1 STEP - 1
    TEMP$ = INPUT$(LOC(1), 1)
    PRINT #1, "SOURce:SAFety:STEP", I%, ":DELeTe"      'clear all steps
data
  NEXT I%
END IF

PRINT #1, "SOURce:SAFety:STEP1:AC:LEVel 500"
PRINT #1, "SOURce:SAFety:STEP1:AC:LIMit:HIGH 0.003"
PRINT #1, "SOURce:SAFety:STEP1:AC:TIME:TEST 3"

PRINT #1, "SOURce:SAFety:STEP2:DC:LEVel 500"
PRINT #1, "SOURce:SAFety:STEP2:DC:LIMIT 0.003"
PRINT #1, "SOURce:SAFety:STEP2:DC:TIME 3"

PRINT #1, "SOURce:SAFety:STEP3:IR:LEVel 500"
PRINT #1, "SOURce:SAFety:STEP3:IR:LIMIT 300000"
PRINT #1, "SOURce:SAFety:STEP3:IR:TIME 3"

PRINT #1, "SOURce:SAFety:SNUMBer?"
INPUT #1, STEPNUM%

PRINT #1, "SOURce:SAFety:START"                'start test

STATUS$ = "RUNNING"
WHILE STATUS$ <> "STOPPED"                      'do while status is not
stopped
  PRINT #1, "SOURce:SAFety:STATUS?"
  INPUT #1, STATUS$                            'read status

  IF STATUS$ = "STOPPED" THEN                  'if status is not TESTING
    PRINT #1, "SOURce:SAFety:STOP"            'send STOP command
    PRINT #1, "SAFety:RESUlt:ALL:OMET?"

    FOR J% = 1 TO STEPNUM%
      INPUT #1, RESULT$
      PRINT "STEP", J%, ":", RESULT$
    NEXT J%
  PRINT

```

```
PRINT #1, "SAFETy:RESUlt:ALL:MMET?"
FOR J% = 1 TO STEPNUM%
    INPUT #1, RESULT$
    PRINT "STEP", J%, ":", RESULT$
NEXT J%
END IF
WEND

PRINT #1, "SOURce:SAFETy:STOP"
CLOSE #1
END
```

6. Description of GPIB/RS-232 Interface (IEEE-488.1)

6.1 Preface

When IEEE-488.1 is set to ON in the SYSTEM SETUP menu (parameter 11), the GPIB/RS-232 commands are accessible (refer to the new command descriptions in this chapter). For a detailed description of all of the IEEE-488.1 commands, refer to the GPIB/RS-232 commands manual.

6.2 IEEE-488.1 Command List

Item	Command	Parameter	Function
1	STOP	X	Stop test
2	TEST	X	Start test
3	SHOW (?)	{c}	Sets the test value
4	STEP (?)	{n}	Sets STEP
5	MODE (?)	{n c}	Sets test mode
6	SOUR (?)	{f}	Sets output voltage or current
7	VOLT (?)	{f}	Sets output voltage
8	CURR (?)	{f}	Sets output current
9	HILI (?)	{f *}	Sets High Limit
10	LOLI (?)	{f *}	Sets Low Limit
11	SARC (?)	{f *}	Sets ARC
12	BOXN (?)	{n}	Sets Box number
13	HICH (?)	{n *}	Sets High Channel
14	LOCH (?)	{n *}	Sets Low Channel
15	TIME (?)	{f *}	Sets test time
16	RAMP (?)	{f *}	Sets voltage ramp time
17	OFST (?)	{c}	Gets the offset
18	*SAV	{n}	Saves setting value
19	*RCL	{n}	Reads setting value
20	CLER	X	Clears the memory
21	*IDN?	X	Queries ID number
22	*DDT (?)	{n c}	Sets response of Trigger command
23	*TRG	X	Executes Trigger command
24	*RST	X	Resets the unit
25	DEV (?)	{n c}	Selects LC human simulation circuit
26	LINE (?)	{n c}	Selects LC test mode
27	POWER (?)	{n c}	Selects LC power measurement
28	PWHI (?)	{f *}	Sets high limit of power measurement
29	PWLO (?)	{f *}	Sets low limit of power measurement
30	PWTV (?)	{f}	Sets target voltage of Simulation
31	LCGS (?)	{1, 0}	Sets Ground Switch (for 6000-05/07/08 only)
32	PUTS (?)	{1, 0}	Sets Pause Mode Under Test

3. The setting value cannot be smaller than the Low Limit on IR Mode, otherwise, Error 2 will be generated.
4. When in GR Mode, the Max. Value is limited by the lesser value of 510.0 and 6300/current, or Error 2 will be generated.
5. When in LC Mode, the max. value depends on human simulating circuit.
6. HILO sets the OPEN CHK range in OSC Mode. The input value range is 1~5 (100%~500%).

3. LOLI(?) {f !*}

Function : Set Low Limit value
 Parameter : Refer to the "HILO" command above

OSC Mode	OPEN CHK.=10%~100%
----------	--------------------

Description:

1. It can be disabled under GR, WV and WD Mode. The Low Limit value cannot be set higher than the High Limit.
2. The LOLI cannot be disabled under IR Mode. The High Limit is disabled if the LOLI value is set higher than the High Limit.
3. LOLI sets the OPEN CHK range in OSC Mode. The input value range is 0.1~1(10%~100%).

4. GETC

Function: Starts the GET Cs function of OSC Mode.
 Parameter: None
 Description: This command can only be executed when setting the OSC Mode in the PROGRAM function list.

5. DWLL(?) {f !*}

Function: Sets the length of the DWELL time (the period of time for the voltage to settle at the programmed level; a.k.a.: delay).
 Parameter: f: 0 ~ 999 second
 Description: The DWLL time can only be set under the DC Withstanding and LC tests.

6. DEV(?) {n !*}

Function: Selects the human simulation circuit in LC mode.
 Parameter : 1. UL544NP
 2. UL544P
 3. UL1563
 4. UL2601-1, IEC610-1
 5. UL1950, UL3101-1, IEC950
 6. UL1950-U1
 7. UL2601-U1

Description: For example, to set the fifth human simulation circuit parameter to "5", select "UL1950", "UL3101-1" or "IEC950".

7. LACHI(?) {f !*}

Function: Sets High Limit of LAC.
 Parameter: 1. "*" : Disabled – no LAC High Limit test is done.
 2. "f" : The max.value is varied by the human simulation circuit, however; it cannot exceed the LC High Limit.

LAC Mode	f = 0.001 ~ 9.999 mA (Max)
----------	----------------------------

8. LDCHI(?) {f !*}

Function: Sets High Limit of LDC.

Parameter: 1. "*" : Disabled - no LDC High Limit test is done.

LDC Mode	f = 0.001 ~ 1.000 mA
----------	----------------------

9. DISP(?) {n !c}

Function: Displays RMS or PEAK for LC leakage current.

Parameter: 0 / RMS = RMS

1 / PEAK = PEAK

Description: This parameter can be set only for 6000-08 testing.

10. FALL(?) {f !*}

Function: Sets the voltage fall time (the period of time for the voltage to decrease back to 0).

Parameter: f: 0 ~ 999 second

Description: FALL can only be set for AC/DC/IR testing.

11. IRRNG(?) {n !c}

Function: Selects IR mode RANGE.

Parameter: 0 = AUTO

1 = 300nA

2 = 3uA

3 = 30uA

4 = 300uA

5 = 3mA

6 = 10mA

7. Calibration Step

The analyzer should be warmed up for at least 30 minutes before starting the calibration procedure in this section. Remove the calibration label from the front panel and press the calibration switch once. When the calibration has been completed, press the calibration switch on the front panel again (this switch is equipped with a hardware protection circuit to avoid calibration data loss).

Voltage Calibration (See 7.2)

ACV	5kV	Offset (500V)	;AC Voltage	OFFSET	point
ACV	5kV	Full (4kV)	;AC Voltage	FULL	point
DCV	6kV	Offset (500V)	;DC Voltage	OFFSET	point
DCV	6kV	Full (4kV)	;DC Voltage	FULL	point
IRV	1kV	Offset (500V)	;IR Voltage	OFFSET	point
IRV	1kV	Full (1kV)	;IR Voltage	FULL	point

Current Calibration (See 7.3)

ACA	3mA	Offset (0.12mA)	;AC 2.99mA	range	OFFSET	point
ACA	3mA	Full (2.5mA)	;AC 2.99mA	range	FULL	point
ACA	40mA	Offset (2.5mA)	;AC 40mA	range	OFFSET	point
ACA	40mA	Full (25mA)	;AC 40mA	range	FULL	point
DCA	3mA	Offset (0.12mA)	;DC 2.99mA	range	OFFSET	point
DCV	3mA	Full (2.5mA)	;DC 2.99mA	range	FULL	point
DCV	12mA	offset (2.5mA)	;DC 20mA	range	OFFSET	point
DCV	12mA	Full (10mA)	;DC 20mA	range	FULL	point

Grounding Mode Calibration (See 7.4)

GBA	30A	Offset (3A)	;GB current	OFFSET	point
GBA	30A	Full (25A)	;GB current	FULL	point
GBV	8V	Offset (0.3V)	;GB voltage	OFFSET	point
GBV	8V	Full (3V)	;GB voltage	FULL	point

Withstanding Voltage Mode Arcing Calibration (See 7.5)

AC	ARC40mA(5mA)	;AC Arcing	Calibration
DC	ARC12mA(5mA)	;DC Arcing	Calibration

Insulation Resistance Mode Leakage Current Meter Calibration (See 7.6 & 7.7)

IRR	Range 1 (1GΩ)	;IR Resistor	range 1	Calibration
IRR	Range 2(100MΩ)	;IR Resistor	range 2	Calibration
IRR	Range 3(10MΩ)	;IR Resistor	range 3	Calibration
IRR	Range 4(10MΩ)	;IR Resistor	range 4	Calibration

7.1 Calibration

Press	[3] [ENTER]
Display	"password"
Press	[7] [9] [3] [1] [ENTER]
Press	[DEVICE]

7.2 Voltage Calibration

7.2.1 ACV Calibration

Connect an ACV high voltage meter to the analyzer or connect a Chroma ATE 9102 Hipot Calibrator and select ACV MODE [100MΩ].

Display ACV 5kV Offset (100V) ; ACV OFFSET POINT calibration
Press [STOP] [START] ; Read the HV meter value
; Example 0.092kV

(Using the keypad, enter the reading from the voltmeter)

Press [0] [.] [0] [9] [2] [ENTER]
Press [STOP] ; Stop ACV OFFSET POINT calibration
Press [△] key
Display ACV 5kV Full (4kV) ; ACV FULL POINT calibration
Press [STOP] [START] ; Read the HV meter value
; Example 4.052kV

(Using the keypad, enter the reading from the voltmeter)

Press [4] [.] [0] [5] [2] [ENTER]
Press [STOP] ; Stop ACV voltage calibration

7.2.2 DCV Calibration

Connect a DCV high voltage meter to the analyzer or connect a Chroma ATE 9102 Hipot Calibrator and select DCV MODE [1.00GΩ].

Press [△] key
Display DCV 6kV Offset (100V) ; DCV OFFSET POINT calibration
Press [STOP] [START] ; Read the HV meter value
; Example 0.092kV

(Using the keypad, enter the reading from the voltmeter)

Press [0] [.] [0] [6] [2] [ENTER]
Press [STOP] ; Stop DCV OFFSET POINT calibration
Press [△] key to display
Display DCV 6kV Full (4kV) ; DCV FULL POINT calibration
Press [STOP] [START] ; Read the HV meter value
; Example 4.052kV

(Using the keypad, enter the reading from the voltmeter)

Press [4] [.] [0] [5] [2] [ENTER]
Press [STOP] ; Stop DCV Voltage calibration

7.2.3 IR Voltage Calibration

Connect a DCV High Voltage meter to the analyzer or connect a Chroma ATE 9102 Hipot Calibrator and select DCV MODE [1.00GΩ].

Press [△] key to display
 Display IRV 1kV Offset (100V) ; IRV OFFSET POINT calibration
 Press [STOP] [START] ; Read the HV meter value
 ; Example 0.092kV

(Using the keypad, enter the reading from the voltmeter)

Press [0] [.] [0] [9] [2] [ENTER]
 Press [STOP] ; Stop IRV OFFSET POINT calibration
 Press [△] key to display
 Display IRV 1kV Full (1kV) ; IRV FULL POINT calibration.
 Press [STOP] [START] ; Read the HV meter value
 ; Example 1.052kV

(Using the keypad, enter the reading from the voltmeter)

Press [1] [.] [0] [5] [2] [ENTER]
 Press [STOP] ; Stop IR voltage calibration

7.3 Current Calibration

 **CAUTION** : The dummy load must be between the high potential terminal and the input terminal of the ammeter. Otherwise, a dangerous situation may occur.

7.3.1 AC Current Calibration

Connect the hipot tester's high potential terminal to a 10MΩ load resistor and then connect to the AC ammeter's high potential terminal in series. Connect the hipot tester low potential terminal to the AC ammeter's low potential terminal or 9102 and select ACA MODE [10MΩ].

Press [△] key to display
 Display ACA 3mA Offset (0.12mA) ; ACA 2.999mA range Offset point calibration
 Press [STOP] [START] ; Read out the ammeter value
 ; Example 0.124mA

Press [0] [.] [1] [2] [4] [ENTER]
 Press [STOP] ; Stop ACA 2.999mA range Offset point calibration

Change the dummy load resistor to 500kΩ 50watt (or higher) or connecting 9102 to select ACA MODE [500kΩ].

Press [△] key to display
 Display ACA 3mA Full (2.5mA) ; ACA 2.999mA range Full point calibration
 Press [STOP] [START] ; Read out the ammeter value
 ; Example 2.903mA

Press [2] [.] [9] [0] [3] [ENTER]
 Press [STOP] ; Stop ACA 2.999mA range calibration
 Press [△] key to display
 Display ACA 40Ma Offset (2.5mA) ; ACA 40mA range Offset point calibration
 Press [STOP] [START] ; Read out the ammeter value
 ; Example 2.903mA

Press [2] [.] [9] [0] [3] [ENTER]
Press [STOP] ; Stop ACA 40.00mA range Offset point calibration

Change the dummy load resistor to 50k Ω 200watt (or higher) or connecting 9102 to select ACA MODE [50k Ω].

Press [Δ] key to display
Display ACA 40mA FULL(25mA) ; ACA 40.00mA range full point calibration.
Press [STOP] [START] ; Read out the ammeter value
; Example 24.50mA

Press [2] [4] [.] [5] [0] [ENTER]
Press [STOP] ; Stop ACA 40.00mA range calibration

7.3.2 DC Current Calibration

Connecting a 10M Ω load resistor in high potential terminal of withstanding analyzer, and series high potential terminal of DC ammeter. However, connect low potential terminal of withstanding analyzer to low potential terminal of DC ammeter or connecting 9102 to select DCA MODE [10M Ω].

Press [Δ] key to display
Display DCA 3mA Offset (0.12mA) ; DCA 2.999mA range Offset point calibration.
Press [STOP] [START] ; Read out the ammeter value
; Example 0.124mA

Press [0] [.] [1] [2] [4] [ENTER]
Press [STOP] ; Stop DCA 2.999mA Offset point calibration

Change the load resistor to 500k Ω 50watt (or higher) or connecting 9102 to select DCA MODE [500k Ω].

Press [Δ] key to display
Display DCA 3mAFULL (2.5mA) ; DCA 2.999mA range full point calibration.
Press [STOP] [START] ; Read out the ammeter value
; Example 2.039mA

Press [2] [.] [0] [3] [9] [ENTER]
Press [STOP] ; Stop DCA 2.999mA range calibration.

Press [Δ] key to display
Display DCA 12mA Offset (2.5mA) ; DCA 12.00mA range Offset point calibration.
Press [STOP] [START] ; Read out the ammeter value
; Example 2.903mA

Press [2] [.] [9] [0] [3] [ENTER]
Press [STOP] ; Stop DCA 12.00mA Offset point calibration.

Change the load resistor to 100k Ω 100watt (or higher) or connect 9102 to select DCA MODE [100k Ω].

Press [Δ] key to display
Display DCA 12mA Full (10mA) ; DCA 12.00mA range full point calibration.
Press [STOP] [START] ; Read out the ammeter value

Press [1] [0] [.] [0] [1] [ENTER] ; Example 10.01mA
 Press [STOP] ; Stop DCA 12.00mA range calibration.

7.4 GBA/GBV Calibration

Connect an ammeter that is over 30Amp by four wires (\pm sense and \pm driver) or a 9102 and select GRA MODE [$>0\Omega$].

Press [Δ] key to display
 Display GBA 30A Offset (3A) ; GRA Offset point calibration.
 Press [STOP] [START] ; Read out the ammeter value
 ; Example 2.897Amp

Press [2] [.] [8] [9] [7] [ENTER]
 Press [STOP] ; Stop GBA Offset point calibration
 Press [Δ] key to display
 Display GBA 30A FULL (25A) ; GRA full point calibration.
 Press [STOP] [START] ; Read out the ammeter value
 ; Example 24.87Amp

Press [2] [4] [.] [8] [7] [ENTER]
 Press [STOP] ; Stop GBA calibration.

Connecting 0.1 Ω 200watts resistor and an ammeter is over 30Amp by four wires (\pm sense and \pm driver) or connecting 9102 to select GRV MODE [0.1000 Ω].

Press [Δ] key to display ; GRV Offset point calibration
 Display GBV 8V Offset (0.3V) ; 3.0Amp into 100m Ω (9102 selects GRV
 [0.1000 Ω])
 Press [STOP] [START] ; Read out GRV value
 ; Example 0.301 volts

Press [0] [.] [3] [0] [1] [ENTER]
 Press [STOP] ; Stop GBV Offset point calibration.
 Press [Δ] key to display ; GRV full point calibration
 Display GBV 8V Offset (3V) ; 30Amp into 100m Ω .(9102 selects GRV
 [0.1000 Ω])
 Press [STOP] [START] ; Read out GRV value
 ; Example 0.301 volts

Press [0] [.] [3] [0] [1] [ENTER]
 Press [STOP] ; Stop GBV Offset point calibration.
 Press [Δ] key to display ; GRV full point calibration
 Display GBV 8V FULL (3V) ; 30Amp into 100m Ω .(9102 selects GRV
 [0.1000 Ω])
 Press [STOP] [START] ; Read out GRV value
 ; Example 3.002 volts

Press [3] [.] [0] [0] [2] [ENTER]
 Press [STOP] ; Stop GBV calibration

7.5 Withstanding Voltage Mode Arcing Calibration

WARNING: ARcing calibration is very special, the high voltage terminal is positioned outside.

Press	[△] key to display	; AC arcing sensitivity calibration.
Display	AC ARC40mA (5mA)	; AC Hipot Arcing.
Press	[STOP] [START]	; The high voltage output terminal series 250kΩ 5watt resistance by using two high voltage cables. The other high voltage cable (grounding cable) is as close as possible to the first cable but doesn't contact each other, and arcing is produced.
Press	[2] [.] [2] [ENTER]	; For example, 2.2mA is critical point of ARC FAIL and ARC PASS.
Press	[STOP]	; Stop AC Arcing calibration.
Press	[△] key to display	; DC arcing sensitivity calibration.
Display	DC ARC12mA (5mA)	; DC Hipot Arcing.
Press	[STOP] [START]	; The high voltage output terminal series 250kΩ 5watt resistance by using two high voltage cables. The other high voltage cable (grounding cable) is as close as possible to the first cable but doesn't contact each other, and arcing is produced.
Press	[2] [.] [4] [ENTER]	; For example, 2.4mA is critical point of ARC FAIL and ARC PASS.
Press	[STOP]	; Stop DC Arcing calibration.

7.6 IRA OFFSET Auto Deduction (No DUT Connected)

Press	[△] key to display	; IRA OFFSET auto deduction.
Display	IRA OFFSET (open)	
Press	[START]	; 100-1000V OFFSET auto deduction (about 50 sec)
Press	[STOP]	

7.7 Insulation Resistance Mode Resistor Calibration

The standard load resistor is connecting between high potential terminal and low potential terminal of withstanding analyzer.

Press	[△] key to display.	
Display	IRR range1 (1GΩ)	; Resistor of IR to 1GΩ
Press	[STOP] [START]	; Read out the IRR value
		; For example 1GΩ

Press [1] [0] [0] [0] [ENTER]
 Press [STOP] ; Stop

Change the standard load resistor to 100MΩ.

Press [△] key to display.
 Display IRR range2 (100MΩ) ; Resistor of IR to 100.0MΩ
 Press [STOP] [START] ; Read out the IRR value
 ; For example 100.0MΩ
 Press [1] [0] [0] [ENTER]
 Press [STOP] ; Stop

Change the standard load resistor to 10MΩ.

Press [△] key to display.
 Display IRR range3 (10MΩ) ; Resistor of IR to 10.0MΩ
 Press [STOP] [START] ; Read out the IRR value
 ; For example 10.0MΩ
 Press [1] [0] [ENTER]
 Press [STOP] ; Stop

Change the standard load resistor to 10MΩ.

Press [△] key to display.
 Display IRR range4 (10MΩ) ; Resistor of IR to 10MΩ
 Press [STOP] [START] ; Read out the IRR value
 Press [1] [0] [ENTER] ; For example 10.0MΩ
 Press [STOP] ; Stop

7.8 Complete Calibration

Press [EXIT]
 [MENU]
 MAIN MENU

8. Firmware Update

To perform a Firmware Update, follow the procedures below.

⚡ CAUTION An error during this procedure may cause abnormal operation or damage to the instrument.

1. Connect the 19032 to the PC with an RS-232 cable.
2. Press the UPDATE button on the front panel after turning ON the instrument. When the power is ON, the LCD should display the following:

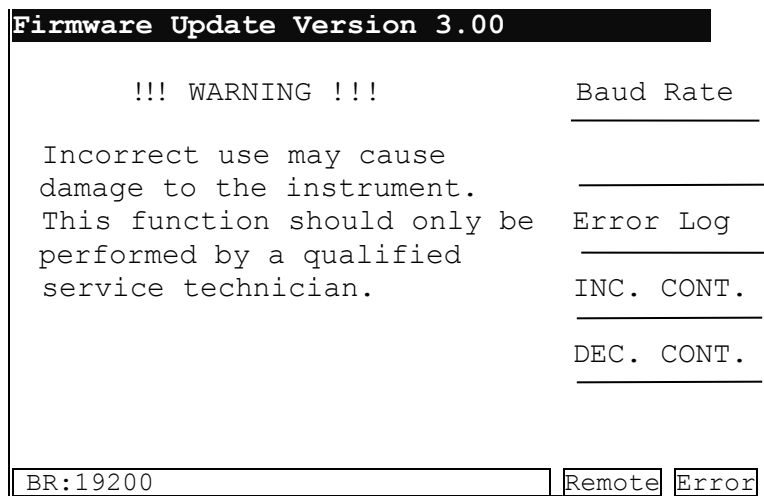
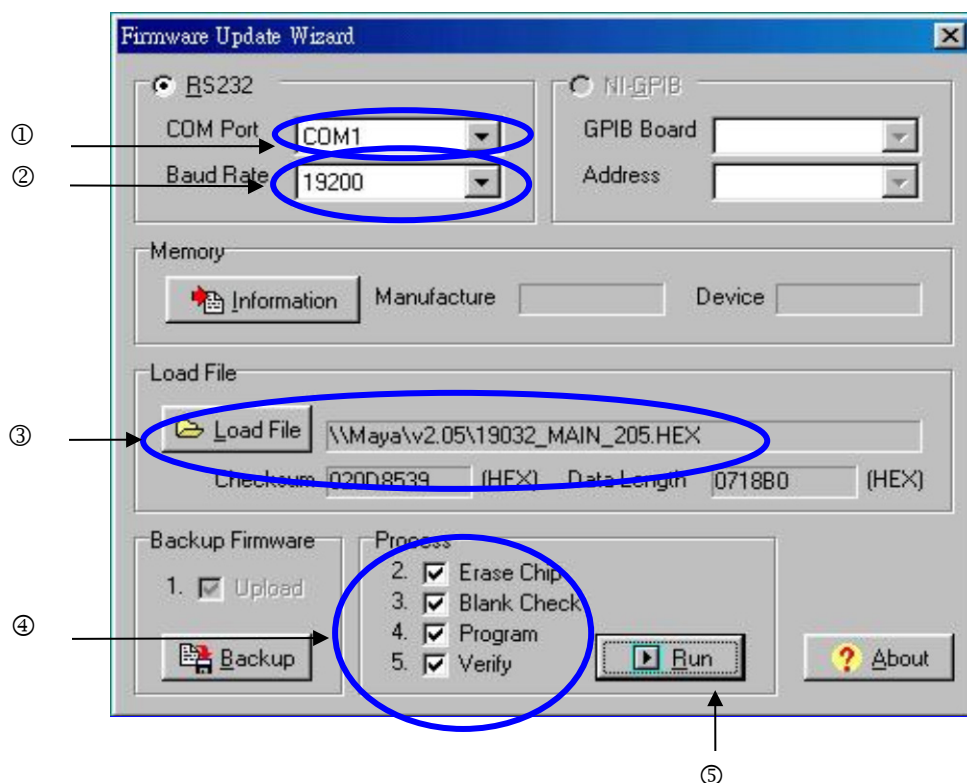

Figure 8-1

3. Run the Firmware Update Wizard on the PC. The splash screen will display:



To update the firmware, follow the steps below:

- ① Select the COM Port to be used.
- ② Set the Baud Rate to 19200 Baud.
- ③ After clicking on the Load File button, select the program to use for the update.
- ④ Select the Erase Chip, Blank Check, Program, and Verify boxes in the Process column.
- ⑤ Click on the RUN button. Wait until Erase Chip, Blank Check, Program, and Verify are completed (about 10 minutes).

As the update progresses, the following screens will appear in sequence:

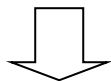
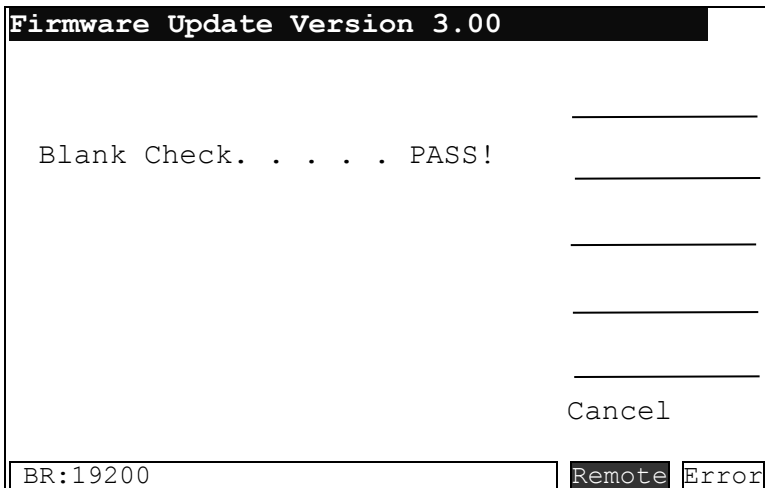
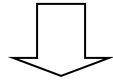
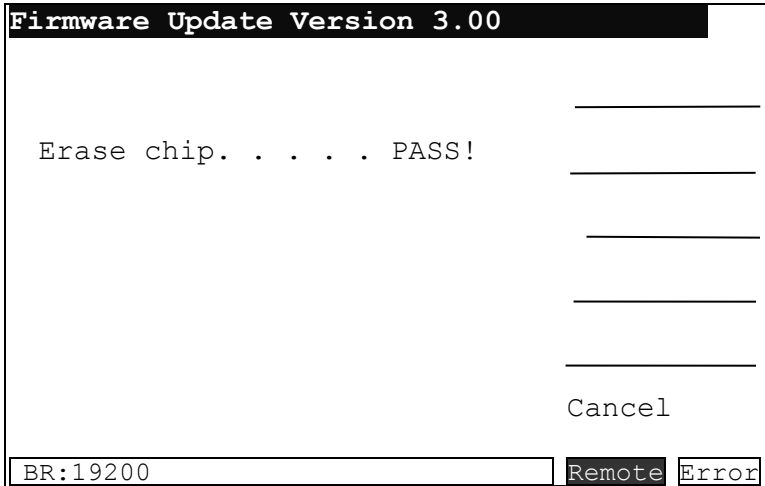

```

Firmware Update Version 3.00

Transmit Firmware:
Write Address: 2AE00 (HEX)  _____
                               _____
                               _____
                               _____
                               _____

Cancel

BR:19200 Remote Error
    
```

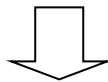

```

Firmware Update Version 3.00

Transmit Firmware:
Read Address: 71935 (HEX)  _____
                               _____
                               _____
                               _____
                               _____

Cancel

BR:19200 Remote Error
    
```

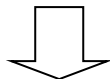

```

Firmware Update Version 3.00

Transmit Firmware:          Baud Rate _____
Read Address: 79980 (HEX)  _____

Transference abort !

Error log _____
INC. CONT. _____
DEC. CONT. _____

BR:19200 Remote Error
    
```

The firmware update is finished after the procedures above have been completed. The PC screen should display:

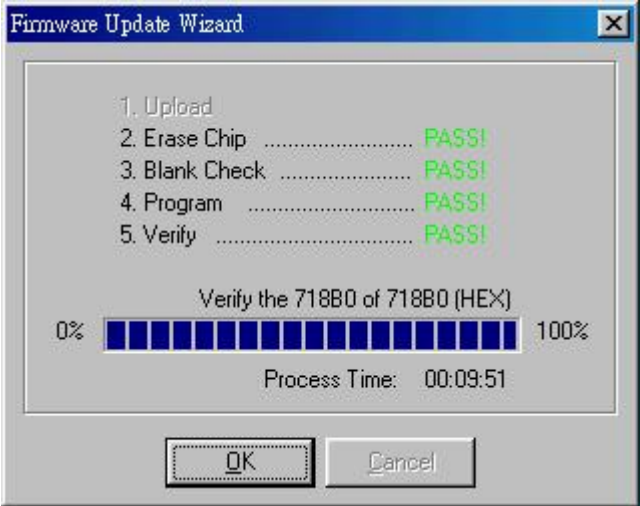

Figure 8-2

After powering-off, press the UPDATE button on the front panel to return to the initial state. Power-on to check if the version has been updated.

9. Maintenance

9.1 General

The warranty (at the front of the manual) attests to the quality of materials and workmanship in the product. If a malfunction should be suspected, or other information is desired, applications engineers are available for technical assistance. Application assistance is available in the Taiwan by calling 886-3-3279999 and asking for applications support. For support outside of the Taiwan contact your local Chroma distributor.

9.2 Battery Replacement

Batteries are included in the analyzer. Contact the service center for battery replacement.

⚠ WARNING Do not attempt to open the cover and replace the battery by yourself.

Batteries Rating

1. Type designation: CR2/38.L
2. Nominal voltage: 3V
3. Typical capacity: 1800mAH (Rated capacity at 200uA to 20°C)
(End-point voltage: 2.0V)

9.3 Instrument Return

Before returning an instrument to Chroma for service, contact the Service Department at 886-3-3279688 for a Return Material Authorization Number (RMA#). Include a purchase order number to ensure expedited processing, although units found to be in warranty will be repaired at no-charge. For any questions on repair costs or shipment instructions contact the service department at the above number. To safeguard an instrument during storage and shipping, use packaging that is adequate to protect it from damage, i.e., equivalent to the original packaging, and mark the box "Delicate Electronic Instrument". Return material should be sent freight prepaid, to:

CHROMA ATE INC.
66 Huaya 1st Road, Guishan, Taoyuan 33383, Taiwan
Attention: Service Department

- ⚡ CAUTION**
1. This instrument is heavy; use a hand truck to avoid injury.
 2. If there is no output signal, disconnect power, open the upper cover and check the fuse (F1/F2) to determine if it has failed. (Amp. fuse rating: 7A/250V slow F1/F2)

Chroma's Continuous Quality Process User Manual Customer Feedback

Chroma welcomes all comments and recommendations to improve this publication in the future editions. Please scan the QR code below or click the URL <http://www.chromaate.com/survey?n=793ce6db-17ef-4cd3-b0de-8bbd09aa38e0> to fill in the customer feedback form. Thank you!





CHROMA ATE INC.

致茂電子股份有限公司

66 Huaya 1st Road,

Guishan, Taoyuan 33383, Taiwan

台灣桃園市 33383 龜山區

華亞一路 66 號

T +886-3-327-9999

F +886-3-327-8898

Mail: info@chromaate.com

<http://www.chromaate.com>